

TC Thermostats Zone Damper Control

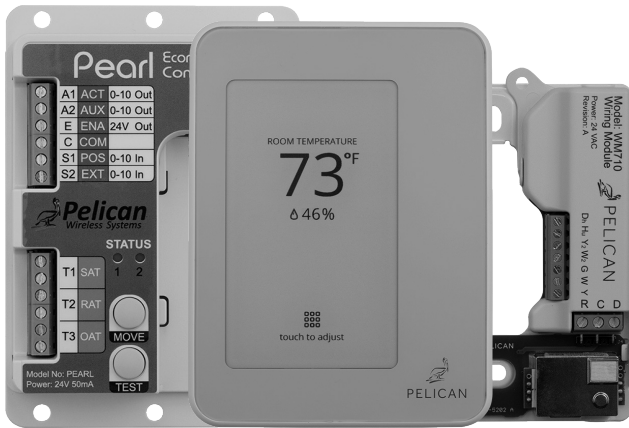

What is a Pelican zone damper controller?

A zone damper controller is comprised of a Pelican thermostat and its accessories. Together these devices control a zone's temperature by adjusting one or multiple dampers and reheats to either provide or restrict cold, hot, or neutral airflow into a space.

This installation manual explains how to wire and configure a Pelican thermostat, and other thermostat accessories, as a zone damper controller. Pelican thermostats can control a variety of different type of mechanical systems. For applications outside of this installation manual, please reach out to Pelican engineering for further assistance.

How does the zoning solution work?

A zone thermostat and its accessories are one piece of the Pelican's zoning solution. Thermostats get installed in the space and, along with their accessories, control individual zone dampers and/or reheat positions to provide zone comfort. Another component required for a Pelican zoning solution to operate is the Pelican zone coordinator. This device gets installed at the central air handler(s) which provides heating, cooling, ventilation, and forced air to the thermostat's zones.

Zone thermostats establish communication with a zone coordinator over Pelicans wireless mesh network. Thermostats send real-time heating, cooling, and ventilation requests to the zone coordinator, which processes these requests and make adjustments to the central equipment to satisfy the different zone

Installation Manual

demands.

Thermostats adjust their dampers and reheats in anticipation of the needed and active cycle. This linked strategy is designed to enhance equipment performance, energy efficiency, and building comfort across the entire mechanical system.

The wireless mesh network also provides an Internet connection for these devices to reach the Pelican Connect app (for more information visit PelicanWireless.com or contact Pelican support). Zone coordinators and their associated thermostats are configured through this web application.

Configurations provide adjustments on how each zone thermostat will control its zone damper and reheats. It also sets which sequences and targets are active. For more information on standard zone thermostat sequences, reference "Sequence of Operations" on page 40.

The Pelican zoning solution and its related devices require an Internet connection for initial device configurations. After configurations are set, the Internet connection provides virtual climate management, data logging, equipment fault notifications, configuration adjustments, and other energy management features. These features are important to verify the correct operation of the zoning solution and should be planned as a retained resource at the end of the installation. If the Internet is down or lost for a period of time, all device configurations are stored locally in each Pelican controller, allowing controllers to operate while the Internet connection is unavailable.

IMPORTANT

A Pelican zone coordinator **MUST** be installed and wired to control the central HVAC equipment for a Pelican zoning solution to work. The zone coordinator both releases thermostats to be configured as zone damper and reheat controllers and allows them to operate.

If the following items cannot be wired and controlled by the zone thermostat, stop the installation immediately and contact Pelican engineering support for further assistance:

- 1) Each zone thermostat **MUST** control when its damper is open and closed.
- 2) Zone dampers **MUST** be able to rotate to their 100% open and 100% closed

position.

- 3) If available, zone thermostats **MUST** control when their reheat is open/closed or active.
- 4) Reheat actuators **MUST** be able to rotate to their 100% open and 100% closed position.
- 5) Each zone thermostat **MUST** be able to communicate its heating, cooling, and ventilation demands to a Pelican zone coordinator.
- 6) A proper Pelican wireless networking **MUST** be established across the facility.
- 7) Each zone thermostat **MUST** be able to directly read its zone's space temperature. And if used, the room's relative humidity (RH%) and/or carbon dioxide (CO2) level.
- 8) Each zone thermostat **SHOULD** be able to read its zone's discharge air temperature.

California Title 24

This device meets California's Title 24 energy efficiency standards.

Safety Considerations

Disconnect electrical power to the power source and/or the HVAC equipment before wiring any Pelican devices. Failure to follow this warning could cause electrical shock, personal injury, or damage to the controller.

Thermostat Parts

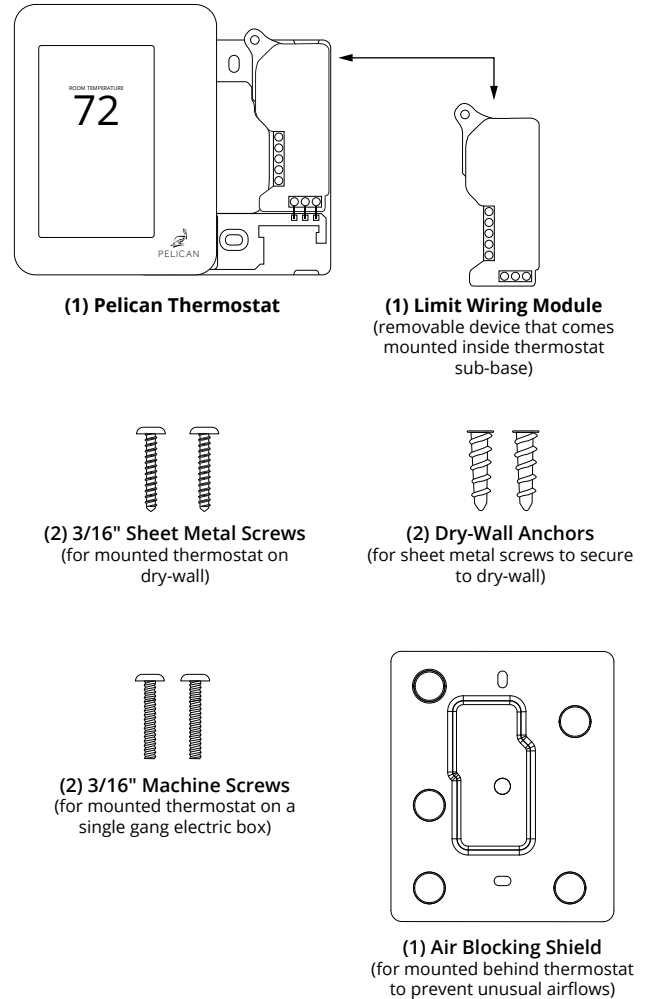

Thermostat Accessories (Sold Separately)

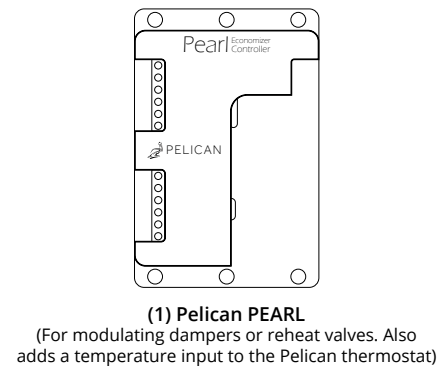
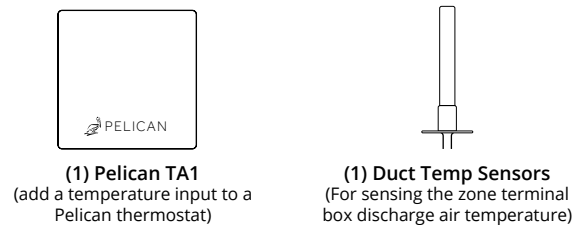

TC Thermostat Specifications

- **Power:** 24V AC, 60 Hz, 105 mA
- **Operating Voltages:** 23 — 30V AC
- **Number of Binary Outputs:**
 - TC1 & TC3: Five (5)
 - TC2 & TC4: Seven (7)
- **Binary Output Relay Ratings:**
 - Y, Y2, G, W, W2: 2.0 A Running
 - Dh & Hu: 1.0 A Running
- **Mounting:** Designed to be mounted on a vertical single gang electrical box or on a flat surface.
- **Wireless:** 2.4 GHz wireless frequency, IEEE 802.15.4 wireless standard. Complies with Class B Part 15 of FCC rules. Does not interfere or communicate with WiFi/802.11 networks. Pelican Mesh Network Enabled.
- **Temperature Deadband:** 3°F differential setting with auto-adjusting to 5°F anti-fighting.
- **Operating Range:** -4°F — 160°F @ 5 % — 90 % Relative Humidity (non-condensing)
- **Humidity Sensor (TC2 & TC4):**
 - Humidify setting: 10 - 80% RH
 - Dehumidify setting: 20 - 90% RH
- **Carbon Dioxide Sensor (TC3 & TC4):** 400 - 2000 PPM detection range. +/- 50 PPM accuracy @ 600 PPM and 1000 PPM, auto-calibrating.
- **Storage Temperature:** -20°F — 160°F
- **Dimensions:**
 - in: 5.2 X 3.9 X 0.75
 - mm: 132 X 99 X 19

TA1 Accessory Specifications

- **Capabilities:** Adds a temperature input to a Pelican thermostat, most commonly used for discharge air temperature detection.
- **Power:** 24V AC, 60 Hz, 50 mA
- **Wiring to Thermostat:** Three (3) low-voltage power and communication wires.
- **Operating Voltages:** 23 — 30V AC
- **Number of Thermistor Inputs:** One (1)
- **Thermistor Type:** 10K Type II (77°F @ 10000 Ohms)

- **Mounting:** Designed to be mounted on a flat surface.
- **Temperature Detection Range:** -20°F to 180°F
- **Operating Range:** -4°F — 160°F @ 5 % — 90 % Relative Humidity (non-condensing)
- **Storage Temperature:** -20°F — 160°F
- **Dimensions:**
 - in: 2.5 X 2.5 X 0.75
 - mm: 63.5 X 63.5 X 19

PEARL Accessory Specifications

- **Zoning Capabilities:** Adds modulating damper and/or reheat control. Also provides multiple temperatures inputs to a Pelican thermostat.
- **Power:** 24V AC, 60 Hz, 50 mA
- **Wiring to Thermostat:** Three (3) low-voltage power and communication wires.
- **Operating Voltages:** 23 — 30V AC
- **Number of Analog Outputs:** Two (2)
- **Analog Output Range:** 0 [2] — 10V DC
- **Number of Analog Inputs:** Two (2)
- **Analog Input Range:** 0 [2] — 10V DC
- **Number of Thermistor Inputs:** Three (3)
- **Thermistor Type:** 10K Type II (77°F @ 10000 Ohms)
- **Temperature Detection Range:** -20°F — 180°F
- **Mounting:** Designed to be mounted at the zone damper equipment it is controlling.
- **Temperature Detection Range:** -20°F to 180°F
- **Operating Range:** -4°F — 160°F @ 5 % — 90 %
- **Storage Temperature:** -20°F — 160°F
- **Dimensions:**
 - in: 3.6 X 5.2 X 1.1
 - mm: 91.4 X 142 X 28

Table of Contents

Introduction	1
What is a Pelican zone damper controller & How does the zoning solution work?	1
Before you start, Zone Thermostat Parts, & Zone Thermostat Accessories	2
Thermostat and Accessory Specifications & Dimensions	3
Installation Planning	6
Installing Thermostats & Accessories	6
Planning - Wireless Networking	6
Planning - Different Mechanical Systems	7
Zone Dampers with-out Reheats	8
Zone Dampers with Reheats	9
Zone Dampers with Fan Powered Boxes	10
Mixing Box / Multi-Zone	11
Dual Duct	12
Wireless	13
Planning Wireless Networking	13
Mounting	14
Zone Thermostat	14
Limited Wire Applications	15
TA1 as Discharge Air Sensor	16
PEARL Accessory	17
Wiring	18
Power	18
Damper Actuators	19
Power-Open / Spring-Closed	19
Power-Closed / Spring-Open	20
Floating: Power-Open / Power-Closed	20
Single Modulating Damper: 0(2) - 10 VDC	21
Mixing Box: Power-Open / Power-Closed	21
Mixing Box: 0(2) - 10 VDC Modulating	22
Dual Duct: Power-Open / Power-Closed	23
Dual Duct: 0(2) - 10 VDC Modulating	24
Reheats	25
Power-Open / Spring-Closed	25
Power-Closed / Spring-Open	26

Floating: Power-Open / Power-Closed	26
Modulating: 0(2) - 10 VDC	27
On/Off: Electric Heat	27
Modulating Electric Heat: 0(2) - 10 VDC	28
Fan Powered Boxes	29
Series Fan Powered Terminal Box	29
Parallel Fan Powered Terminal Box	30
Notes	31
Start-Up	32
Before Start-up	32
Attach Thermostat Display to Back Plate	32
Tamper Resistant Lock	33
Power & Connectivity Troubleshooting	33
Setting Configurations	34
Configurations	35
Configurations	35
Input Configurations	38
Advanced Configurations	39
Sequence of Operations	40
Sequence of Operations	40
Appendix	46
A: Signal Outputs	46
B: Max Damper Positions	47
C: Min Ventilation Positions	47

Before You Start

Review all instructions in this installation manual before starting to avoid discovering or creating any issues during installation. These controllers are designed to be installed on Class 2 - 24V AC systems only.

This controller is designed to be installed by a licensed professional.

A Pelican Gateway must be installed and have a fully established Ethernet connection to set up and use the Pelican zoning solution. Zone thermostats cannot be configured, commissioned, or managed without a gateway and a zone coordinator part of the wireless network. We recommend installing the gateway and zone coordinator prior to installing zone thermostats.

Planning - Thermostat Installation

We recommend following these steps when planning and installing a zone thermostat and its accessories:

- 1) Plan your installation needs based on the equipment and mechanical design of the zone dampers, reheats, and local fan control requirements; "Planning - Different Mechanical Systems" on page 7.
- 2) Plan wireless networking so thermostats are able to connect and communicate with the Pelican wireless network; "Planning - Wireless Networking" on page 13.
- 3) Plan mounting locations so the zone thermostats will be in an optimal location for accurate zone/room temperature, humidity, and carbon dioxide readings, whichever applies to your application; "Mounting - Zone Thermostat" on page 14.
- 4) Install a Pelican Gateway, verify it has Ethernet access, and set up your Pelican Connect app.
- 5) Follow the Zone Coordinator installation guide and complete all steps to power it and verify it is connected to the Pelican mesh network.
- 6) Mount any accessories and complete wiring devices to dampers, reheats, and terminal fans; "Mounting and Wiring" - page 14 to 32.
- 7) Wire the controllers to power; "Wiring - Power" on page 18.
- 8) Start-up, confirm power, and ensure all communication is active; "Start-Up" on page 32 & 33.
- 9) Configure the controller; "Configurations" from pages 35 to 39.

NOTE: If you need to keep the equipment active while transitioning the existing system over to being controlled by the Pelican zoning solution, reference the steps in the Zone Coordinator installation guide for further instructions.

Planning - Wireless Networking

It is essential to plan the wireless network before installing the zone thermostats and other wireless devices. Page 13 offers various scenarios, diagrams, and requirements for correctly networking thermostats and controllers. If your application is outside the scope of this installation manual, please stop the installation and contact Pelican engineering support for further assistance.

Each Pelican zone thermostat package includes two components: the thermostat itself, which features a front touch display and a mountable back plate, and the thermostat's wiring module, which provides the output terminals. The front display contains the wireless antenna for communication. The wiring module comes pre-mounted in the back plate but can be separated and mounted elsewhere, then wired back to the thermostat. This design simplifies installation and networking.

Optimal mounting location depends on the availability of existing wiring or the ease of adding new wiring to connect the zone thermostat to the zone damper and reheat it controls.

Once powered, the thermostat automatically discovers and establishes a 2-way communication link with the Pelican wireless network, other Pelican thermostats, the Pelican zone coordinator, and the Pelican gateway.

The thermostat stores all its configurations, routes, and logic in its integrated memory. It manages zone schedules and other demands, using internal logic algorithms to adjust the zone damper and reheat to achieve the desired room temperature. Central equipment adjustments are managed by the zone coordinator. All changes, temperatures, and other operations are tracked and synced to the Pelican Connect app for sequencing, data logging, and historical tracking.

Additional considerations for networking and wireless communication:

- Install a Pelican Gateway in a central location within the building to ensure communication with a high percentage of Pelican devices and maintain a stable Internet connection.
- Pelican thermostats typically serve as primary wireless repeaters, bridging the wireless network across the facility. In some cases, plan to install thermostats early to help extend the wireless network. Refer to the zone coordinator installation guide for more information on transitioning a building to Pelican control.
- Pelican offers wireless repeaters to extend the network around a facility. Contact Pelican support for assistance with using repeaters.

Planning - Different Mechanical Systems

There are five common zone terminal box designs that a Pelican thermostat and its accessories can retrofit and control.

Pages 8–12 provide diagrams and identify necessary Pelican devices required for Pelican to control each mechanical system. Note that both the zone damper and the central air handler require Pelican controllers.

For more applied controls wiring diagrams, reference “Wiring - Damper Actuators, Reheats, & Fan Powered Boxes” from pages 19 to 31.

If your application is outside the scope of this installation manual, please stop the installation and contact Pelican engineering for further assistance.

Planning - Different Mechanical Systems - Zone Dampers Without Reheats

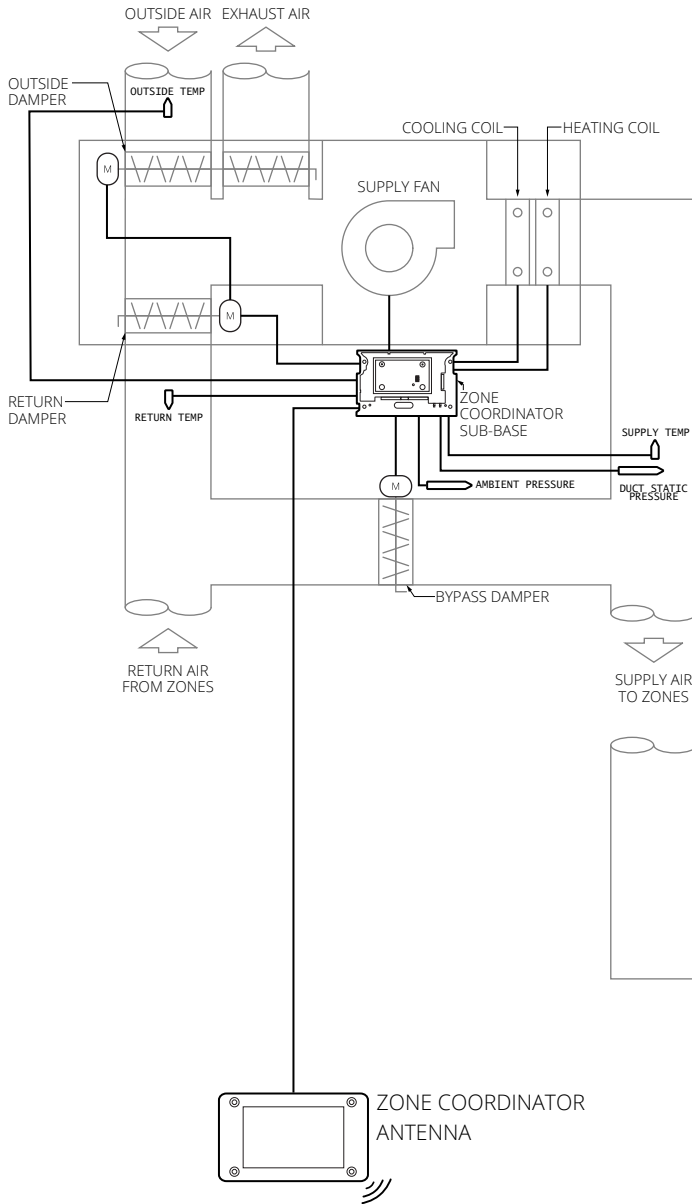

This type of system typically consists of a single air handler that provides heating, cooling, and ventilation to multiple zones. There is commonly a bypass damper, which is modulated to maintain supply duct static pressure. Each zone has a local damper controlled by a Pelican thermostat, which opens and closes to regulate airflow into the respective space. A Pelican TA1 is generally added to the thermostat for discharge temperature monitoring and damper proving. A Pelican PEARL can be added to the thermostat for modulating damper control applications. In these systems, zone reheat is rare.

Requirements for this Installation

Each zone will need its own Pelican thermostat to control its zone damper actuator. Thermostats will need an accessories for discharge temperature monitoring. The central air handler will need a Pelican zone coordinator; refer to the zone coordinator installation guide: "Planning - Different Mechanical Systems - Variable Temperature and Air Volume (VVT)."

For more details on wiring the zone thermostat and accessories to each control point, follow the wiring diagrams starting on page 18 of this installation manual.

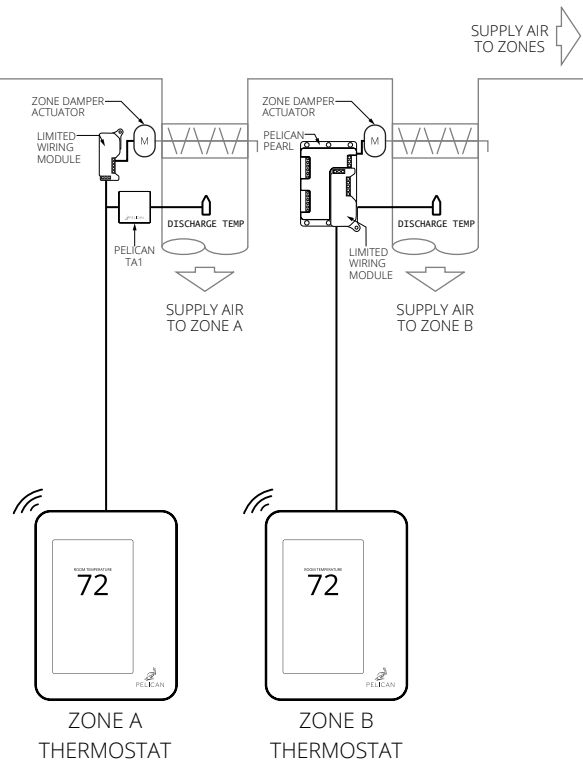

Planning - Different Mechanical Systems - Zone Dampers With Reheats

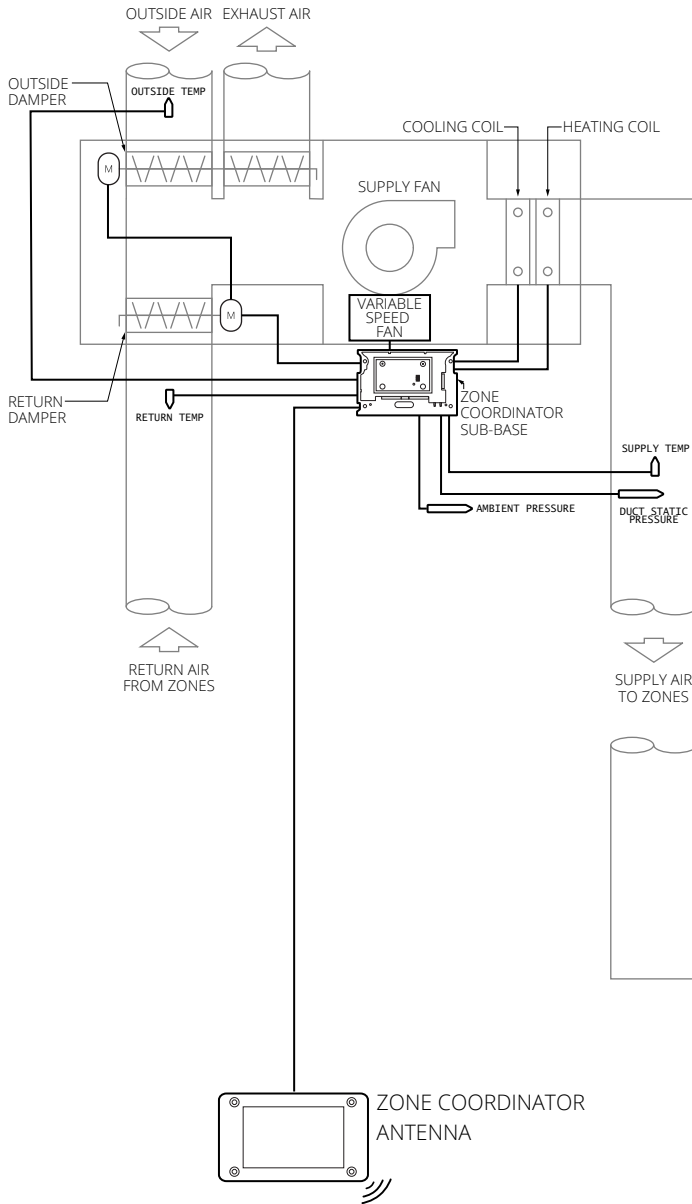

This type of system typically consists of a single air handler that provides cooling and ventilation to multiple zones. Sometimes the air handler includes central heating for morning warm-up or other heating cycles. There is commonly a variable speed supply fan, which is modulated to maintain supply duct static pressure. Each zone has a local damper controlled by a Pelican thermostat, which opens and closes to regulate airflow into its space. Zones also have a reheat coil that can be enabled, opened/closed, or modulated to heat the air entering the space. A Pelican PEARL can be added to the thermostat for modulating damper and/or reheat control applications.

Requirements for this Installation

Each zone will need its own Pelican thermostat to control its zone damper actuator and, if applicable, the zone reheat. Thermostats will need an accessories for discharge temperature monitoring and/or control. The central air handler will need a Pelican zone coordinator; refer to the zone coordinator installation guide: "Planning - Different Mechanical Systems - Variable Air Volume (VAV)."

For more details on wiring the zone thermostat and accessories to each control point, follow the wiring diagrams starting on page 18 of this installation manual.

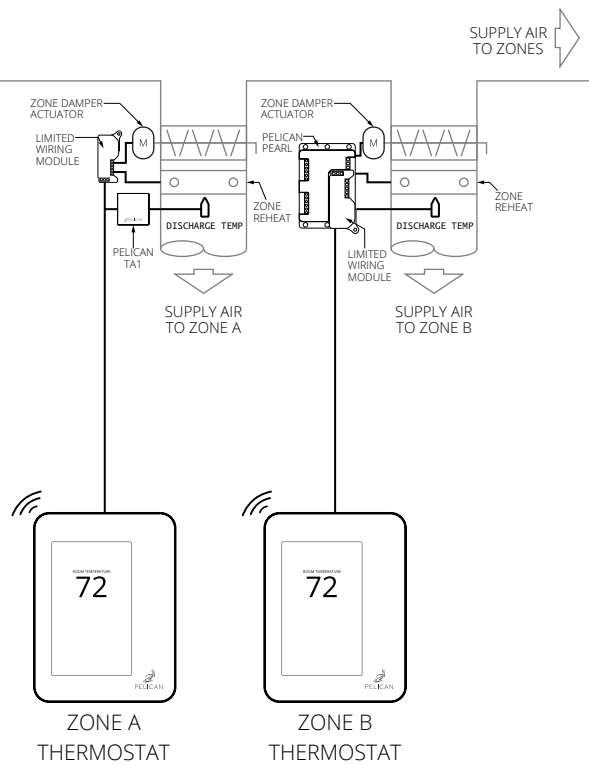

Planning - Different Mechanical Systems - Zone Dampers with Fan Powered Boxes

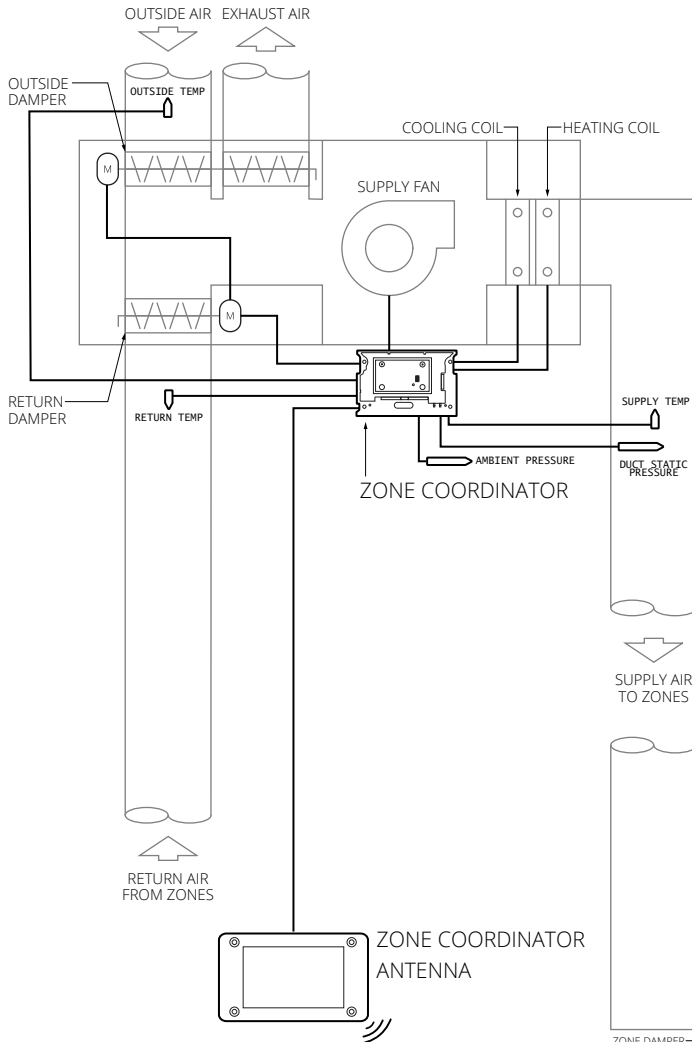

This type of system typically consists of a single air handler that provides cooling and ventilation to multiple zones, similar to the systems on Pages 8 and 9. The primary difference is that some or all zones have a local fan which gets enabled by the Pelican thermostat.

There are two types of fan-powered boxes:

- **Series Fan Powered:** The fan operates during heating, cooling, and ventilation cycles.
- **Parallel Fan Powered:** The fan operates during reheat cycles.

Requirements for this Installation

The installation requirements are the same as for the systems outlines on page 8 and 9 in this installation guide.

For detailed wiring instructions for the zone thermostat and accessories to each control point, refer to the wiring diagrams starting on page 18 of this installation manual.

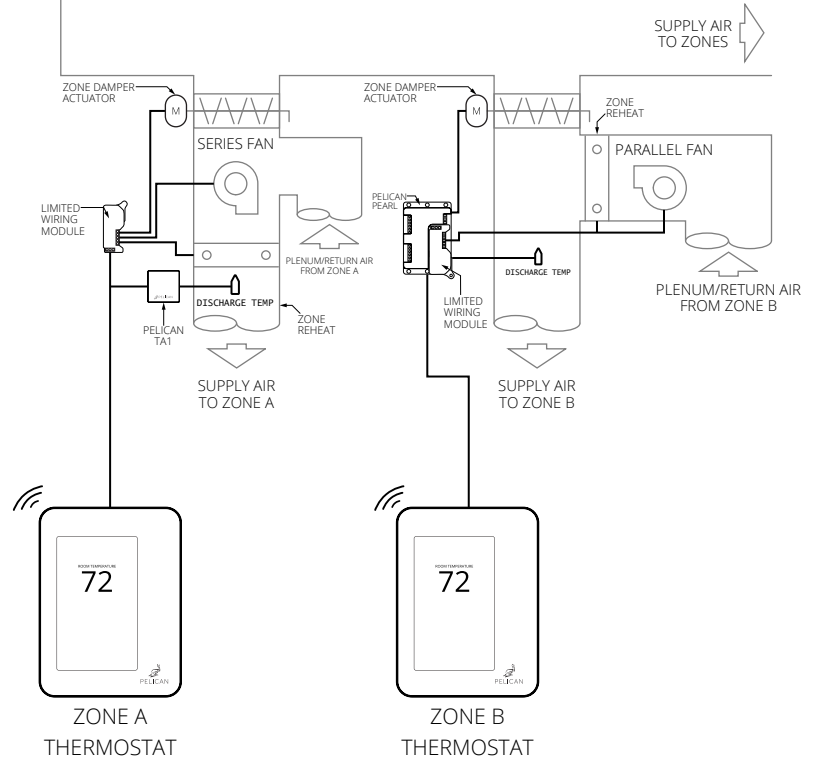

Planning - Different Mechanical Systems - Mixing Box / Multi-Zone

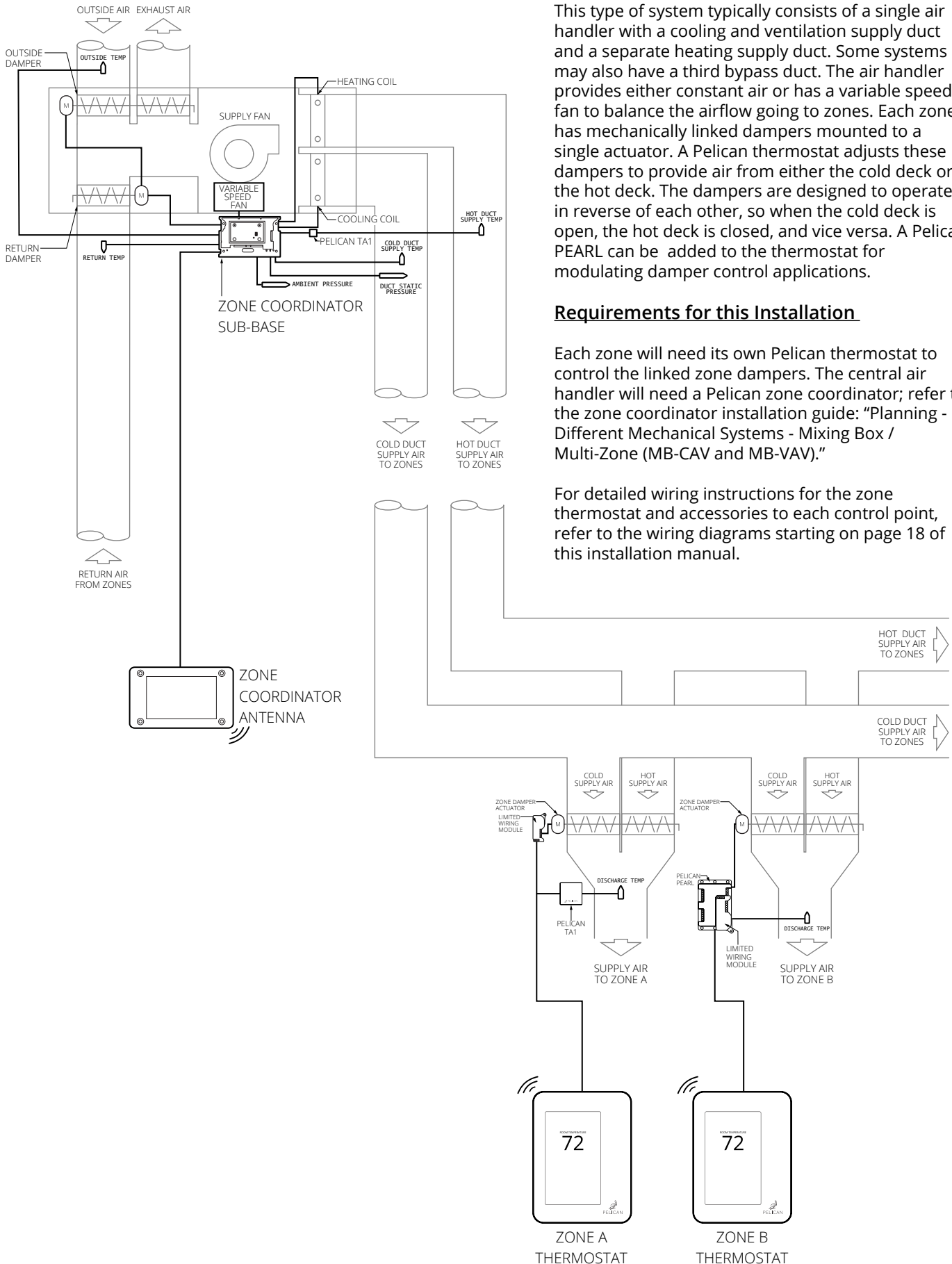

This type of system typically consists of a single air handler with a cooling and ventilation supply duct and a separate heating supply duct. Some systems may also have a third bypass duct. The air handler provides either constant air or has a variable speed fan to balance the airflow going to zones. Each zone has mechanically linked dampers mounted to a single actuator. A Pelican thermostat adjusts these dampers to provide air from either the cold deck or the hot deck. The dampers are designed to operate in reverse of each other, so when the cold deck is open, the hot deck is closed, and vice versa. A Pelican PEARL can be added to the thermostat for modulating damper control applications.

Requirements for this Installation

Each zone will need its own Pelican thermostat to control the linked zone dampers. The central air handler will need a Pelican zone coordinator; refer to the zone coordinator installation guide: "Planning - Different Mechanical Systems - Mixing Box / Multi-Zone (MB-CAV and MB-VAV)."

For detailed wiring instructions for the zone thermostat and accessories to each control point, refer to the wiring diagrams starting on page 18 of this installation manual.

Planning - Different Mechanical Systems - Dual Duct

This type of system consists of two air handlers with separate ducts traveling from each air handler to multiple zones. One air handler provides cooling and ventilation, while the second air handler provides heating and transfer air. Both air handlers commonly have their own supply fans, with either a variable speed drives or a bypass damper, which is modulated to maintain supply duct pressure. In some applications, they share a fan (contact Pelican support for assistance with linked fan control). Each Pelican thermostat controls two separate dampers, each with its own actuator. These actuators operate independently, allowing the zone thermostat to open the cold duct for cooling and ventilation or the hot duct for heating and transfer air. A Pelican PEARL can be added to the thermostat for modulating damper control applications.

Requirements for this Installation

Each zone will need its own Pelican thermostat to control the two separate zone damper actuator position. Both central air handlers will need their own Pelican zone coordinator; refer to the zone coordinator installation guide: "Planning - Different Mechanical Systems - Dual Duct (DD-VAV)."

For detailed wiring instructions for the zone thermostat and accessories to each control point, refer to the wiring diagrams starting on page 18 of this installation manual.

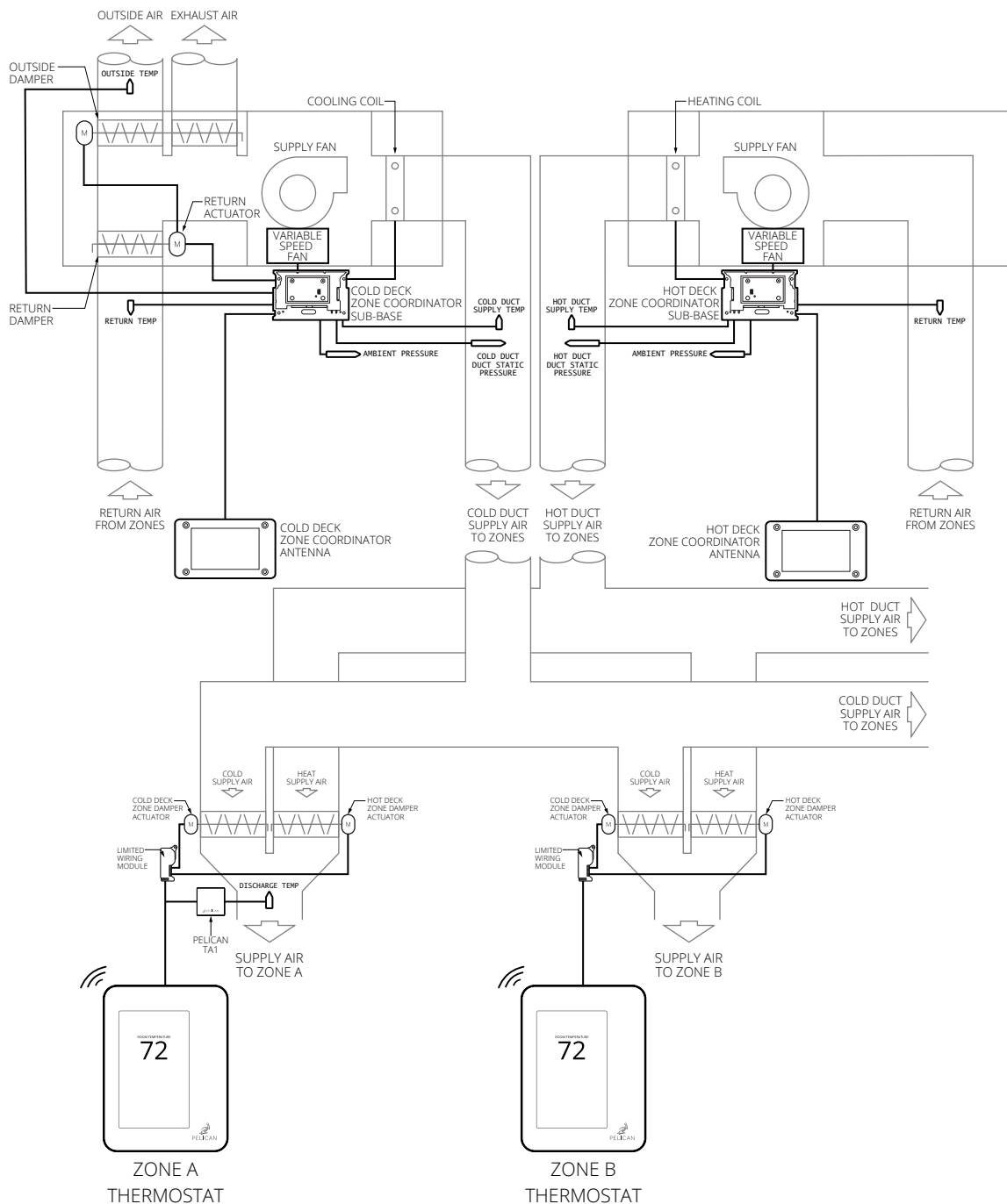

Planning - Wireless Networking

Effective wireless mesh network planning is essential before installing any Pelican device. Each zone thermostat must communicate within the wireless network to send zone demands to a zone coordinator and receive information from other devices. This two-way communication link allows the entire zoned system to operate seamlessly. Below are key considerations for effective wireless planning and examples of how wireless communication can be established throughout the building.

Items to Plan for Networking and Wireless Communication:

1. Pelican Gateway Installation:

- Install the Pelican gateway in a central location inside the building where it can communicate with a large number of Pelican devices and maintain a stable connection to the Internet.

2. Thermostat Bridging:

- Recognize that each Pelican thermostat is used to bridge the wireless network across the facility. In some applications, plan to install all thermostats early on to help extend the wireless network around the building.

3. Using Wireless Repeaters:

- Install Pelican repeaters to bridge communication gaps in the wireless network.

Metal Enclosures and Wireless Interference: Never install a Pelican wireless transmitting device, such as antennas or thermostats, inside a metal enclosure or near a solid metal structure since metal blocks and interferes with wireless signal quality and strength.

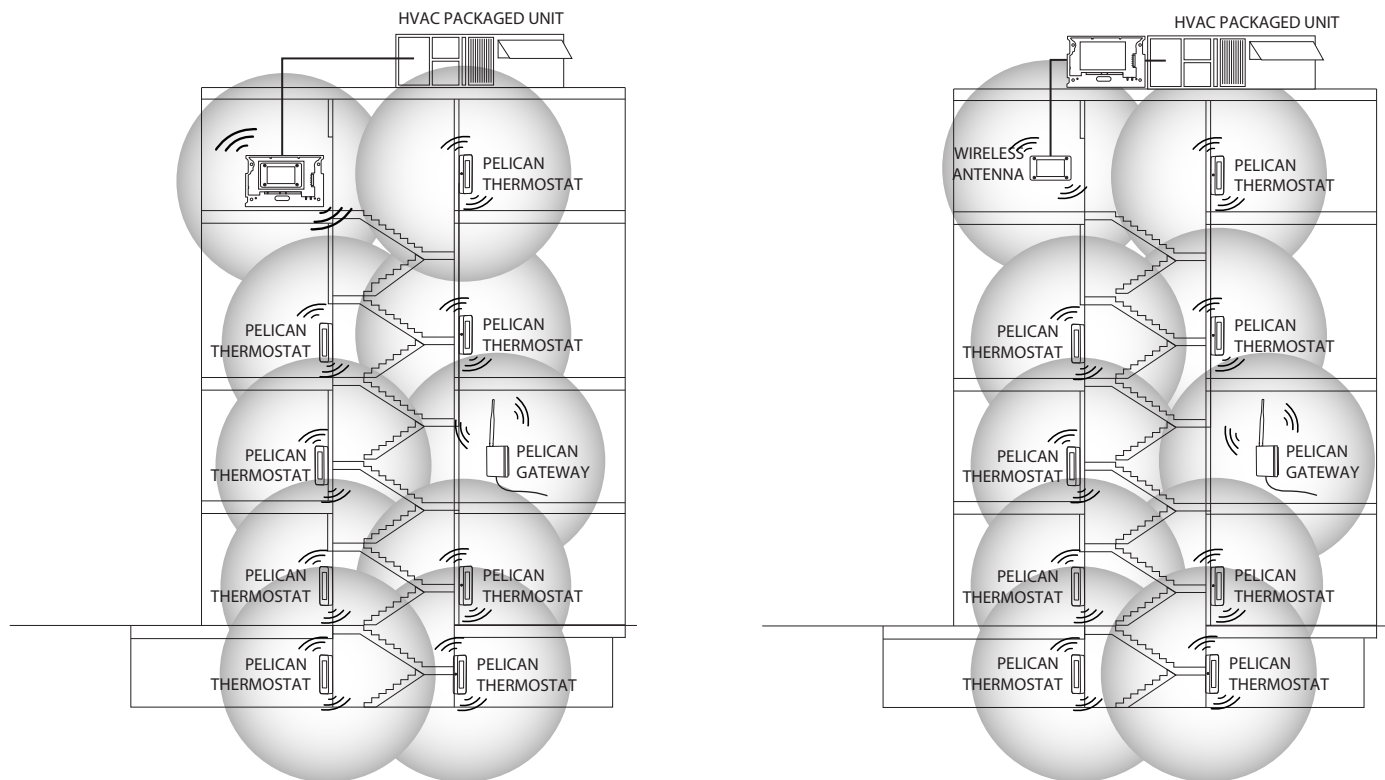

Mounting - Zone Thermostat

When installing Pelican Thermostats, ensure the following:

- **Location for Wireless Communication:** Install in a location where the thermostat can communicate effectively with the Pelican wireless mesh network.
- **Height Placement:** Mount the thermostat 48" to 60" from the floor within the room/zone it will control.
- **Avoid Obstructions:** Install on an interior wall away from doors, filing cabinets, electrical equipment, or other metal objects.
- **Ease of Wiring:** Choose a location that allows convenient wiring to the zone's damper(s), reheat(s), and any local fans.
- **Interior Wall Air Management:** Make sure no air is moving into or out of the wall behind the thermostat. Install air shield to prevent unusual air movement.

IMPORTANT

NEVER INSTALL A PELICAN THERMOSTAT IN AN ENCLOSED METAL BOX OR ON A METAL SURFACE. THE THERMOSTAT'S ANTENNA IS INTEGRATED WITHIN THE THERMOSTAT UNIT (NOT IN THE WIRING MODULE), AND WIRELESS SIGNALS CANNOT PENETRATE METAL.

For additional mounting information, refer to the thermostat's published Installation and Operation Manual (IOM). If more information is needed, contact Pelican engineering support.

Mounting - Thermostat Back Plate

Use the included screws to attach the thermostat to the wall following one of the examples below:

Electrical Box Installation:

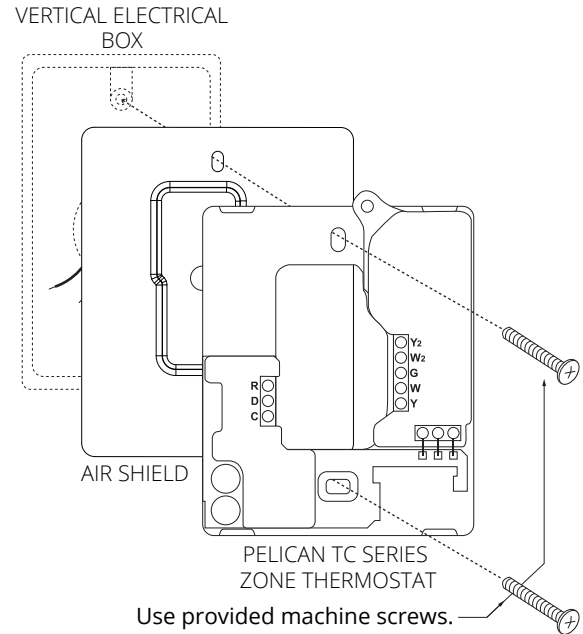

Wall Installation:

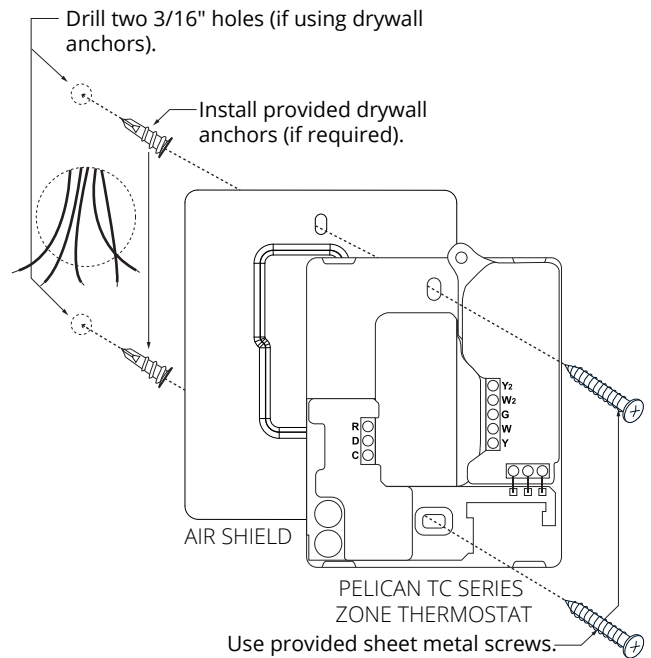

Mounting - Limited Wire Applications

In installations where there are limited wires between the thermostat and their zone damper(s), reheat(s), or terminal box fans, Pelican includes a Limited Wiring Module with each thermostat. This module allows control of these mechanical devices without the need for running new or additional wires from the damper to the thermostat.

Installation Requirements:

- **Minimum Wire Count:** At least three (3) wires are required between the thermostat and the Limited Wiring Module (unshielded wire is acceptable).
- **Maximum Wire Distance:** The maximum wire distance between the Limited Wiring Module and the thermostat is 500 feet.

This solution ensures that even in installations with limited wiring, the Pelican thermostats can effectively control the necessary mechanical devices.

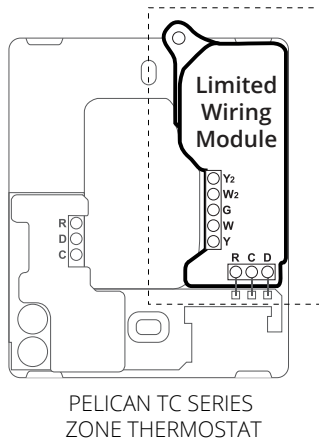

Step 1: Remove the Wiring Module from the Thermostat's Back Plate.

- **Loosen the Terminals:** Loosen the R, C, and D terminals on the Wiring Module.
- **Remove the Wiring Module:** Gently slide the Wiring Module upwards, away from the three-pin connector, to detach it from the thermostat's back plate.

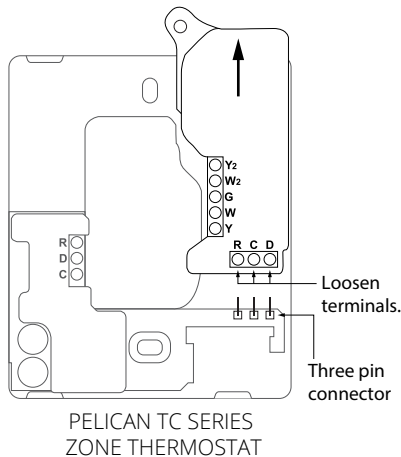

Step 2: Install the Wiring Module at the Zone Damper.

Locate the Zone Terminal Box Damper: Identify the location of the zone terminal box damper where the Wiring Module will be installed.

Connect the Thermostat: Using existing or new 18-gauge wire, connect the Wiring Module's power and communication terminals to the corresponding power and communication terminals at the Pelican thermostat.

Ensure each connection is secure and corresponds correctly:

- R terminal (24V AC) to the respective R input
- C terminal (Common) to the respective C input
- D terminal (Data) to the respective D input

Wire to Damper Actuator & Reheat: Using existing or new 18-gauge wire, connect the Wiring Module's terminals to the corresponding low-voltage input terminals at the zone terminal box damper.

For controls wiring application diagrams, reference pages 19 to 31.

Wire to Power: Refer to "Wiring - Power" diagram on page 18 for instructions.

Use a sheet metal screw to secure the Wiring Module.

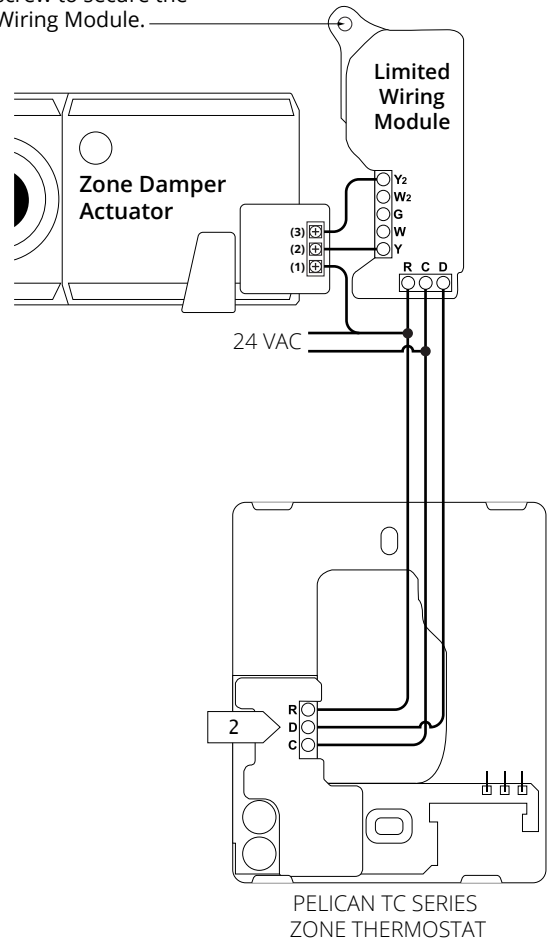

Mounting - TA1 as Discharge Air Sensor

For all zone damper installations, it is recommended to install a zone discharge air sensor. When a Pelican PEARL is not required, the Pelican TA1 can be used to provide this feature.

Installation Requirements:

- **Minimum Wire Count:** At least three (3) wires are required between the thermostat and the TA1 (unshielded wire is acceptable).
- **Maximum Wire Distance:** The maximum wire distance between the TA1 and the thermostat is 500 feet.
- **Thermister:** The TA1 accepts a 10K Type 2 temperature sensor.

This solution ensures that even in installations with limited wiring, the Pelican thermostats can monitor the zone damper's operation.

Step 1: Install the thermostat Wiring Module at the Zone Damper

Follow the steps found on page 15.

Step 2: Mount and connect the TA1.

Securely attach the TA1 to the zone terminal box. Connect the TA1's power and communication terminals to the corresponding terminals going to the Pelican thermostat using existing or new 18-gauge wire.

Ensure each connection is secure and corresponds correctly:

- R terminal (24V AC) to the respective R input
- C terminal (Common) to the respective C input
- D terminal (Data) to the respective D input

Wire to Actuator(s) & Power: Refer to "Wiring" diagrams from page 18 to 31 for instructions.

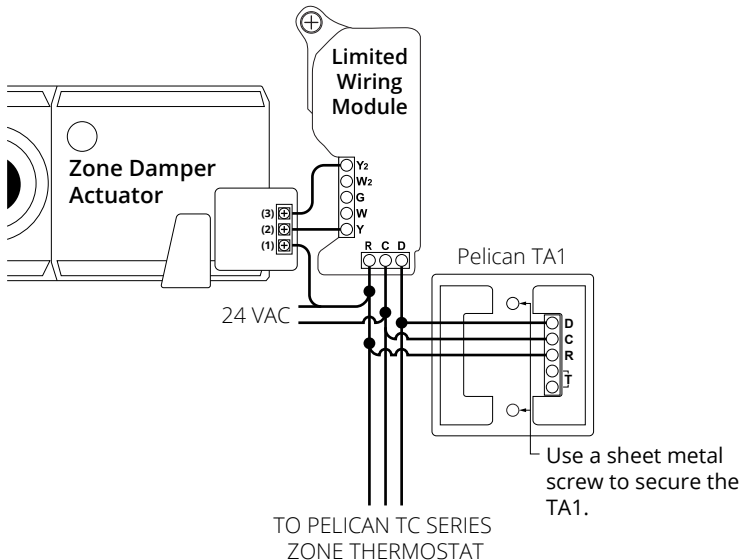

Step 3: Install the 10K Type 2 Thermister.

Determine a location for installing the discharge air sensor to detect an accurate leaving air temperature. Ensure this location is after the zone damper and beyond any reheats.

Wire to TA1: Using existing or new 18-gauge wire connect the sensor to the T inputs on the TA1.

- **Maximum Wire Distance:** 100 feet.
- ***IMPORTANT* Configuration:** Configure the thermostat to register the connected sensor as the Supply Temperature.

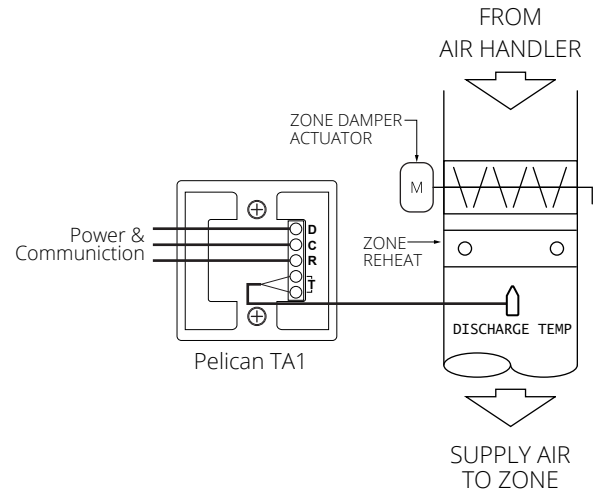

Mounting - PEARL Accessory

For zone damper installation where there is a modulating damper and/or a modulating reheat, the Pelican PEARL provides analog 0 [2] — 10V DC outputs and a zone discharge temperature inputs for modulating sequences to operate. A zone discharge air sensor must be wired to the PEARL in this application.

Installation Requirements:

- **Minimum Wire Count:** At least three (3) wires are required between the thermostat and the PEARL (unshielded wire is acceptable).
- **Maximum Wire Distance:** The maximum wire distance between the PEARL and the thermostat is 500 feet.
- **Thermister:** The PEARL accepts a 10K Type 2 temperature sensor.

This solution ensures that even in installations with limited wiring, the Pelican thermostats can effectively modulate and monitor the zone damper's operation.

Step 1: Install the thermostat Wiring Module into the PEARL and install them at the Zone Damper.

- **Remove the Wiring Module:** Follow steps on page 15 to remove the Wiring Module from the Pelican Thermostat.
- **Install into PEARL:** Gently slide the Wiring Module upwards, towards the three-pin connector.
- **Tighten the Terminals:** Tighten the R, C, and D terminals on the Wiring Module.

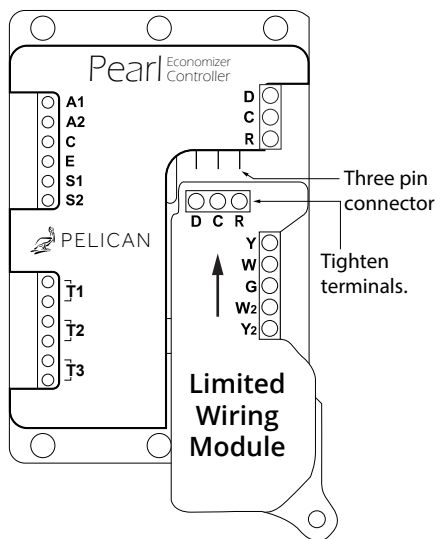

Step 2: Mount and connect the PEARL.

Securely attach the PEARL to the zone terminal box. Connect the PEARL's power and communication terminals to the corresponding terminals going to the Pelican thermostat using existing or new 18-gauge wire.

Ensure each connection is secure and correctly matched:

- R terminal (24V AC) to the respective R input
- C terminal (Common) to the respective C input
- D terminal (Data) to the respective D input

Wire to Actuator(s) & Power: Refer to "Wiring" diagrams from page 18 to 31 for instructions.

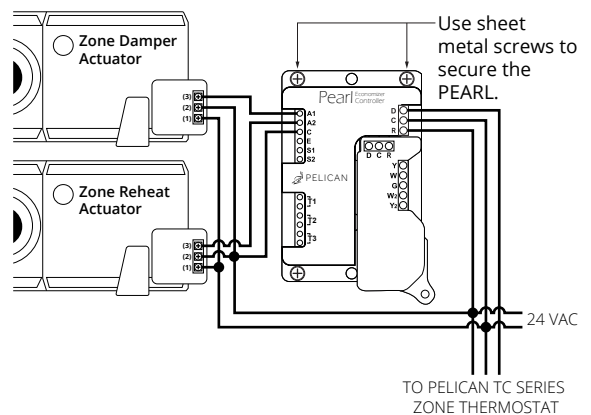

Step 3: Install the 10K Type 2 Thermister.

Determine a location for installing the discharge air sensor to detect an accurate leaving air temperature. Ensure this location is after the zone damper and beyond any reheats.

Wire to PEARL: Using existing or new 18-gauge wire connect the sensor to the T1 inputs on the PEARL.

- **Maximum Wire Distance:** 100 feet.
- **IMPORTANT* Configuration:** Configure the thermostat to register the connected sensor as the Supply Temperature.

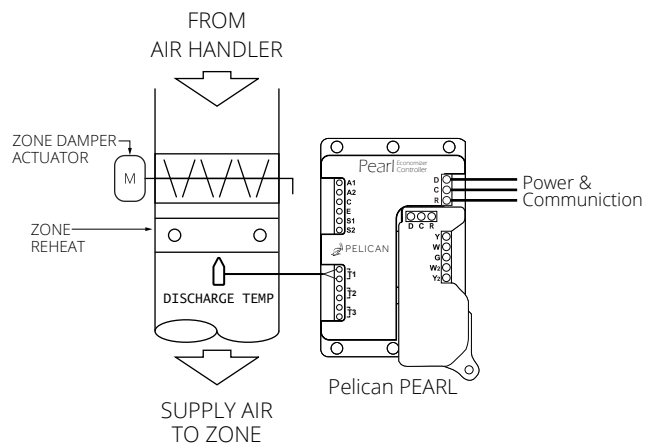

Wiring - Power

Pelican zone thermostats and their accessories must be powered by a 24V AC Class 2 power source. To prevent electrical shock, personal injury, or damage to the controller, always disconnect electrical power to the power source before wiring anything to the Pelican hardware.

IMPORTANT

AVOID CONNECTING POWER TO ANY INPUTS OR OUPUTS NOT SPECIFICALLY DESIGNATED FOR POWER. TAKE EXTREME CAUTION WHEN WIRING POWER TO THE CONTROLLER(S).

Using an Auxiliary 24V AC Transformer:

- 1) Follow the transformer installation manual for directions on how to install the transformer.
- 2) Before wiring any Pelican devices to the transformer, turn power ON to the transformer and verify that the voltage measured is within the device's operating range of 23 - 30V AC.
- 3) Turn power OFF to the transformer.
- 4) Wire all Pelican controller R terminals to 24V AC and C terminals to Common at the transformer.
- 5) Turn power ON to the transformer and verify that the thermostat's and its accessories power On & Internal Status LEDs begin to operate; refence thermostat and accessorie IOMs for further details.

Transformer Va Requirements:

When calculating the Va rating of your transformer, add up the Pelican components, the actuators, and any other 24V AC Volt-Amp (VA) requirements. Then multiple that by the number of zones that will be wired to that power source.

TC Thermostat	2.52	VA
TA1	1.20	VA
PEARL	1.20	VA
Damper Actuator		VA
Reheat Actuator		VA
		VA
		VA

Total VA

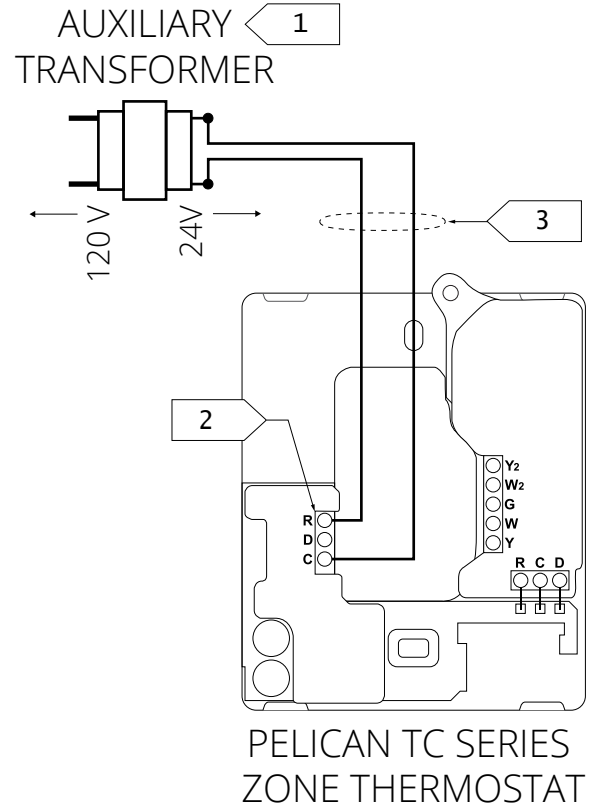

- 1) 24 VAC Class 2 Power.
- 2) Only install one (1) wire into each of the controller's terminals. Use wire nuts where required.
- 3) Unshielded 18 gauge thermostat wire recommended.

Wiring - Damper Actuators

Pelican thermostats and accessories can be wired and configured to control a wide range of zone dampers. Refer to the "Installation Planning" diagrams on pages 6 to 12 for the most common applications. It is essential you follow the following wiring diagrams, as the controller's outputs are closely linked to their configured functions.

Verify proper mechanical operation before and after installation and ensure that all configurations are accurate for your installation.

For installations outside of these diagrams, stop what you are doing and contact Pelican support for further assistance.

Two-Position and Floating Dampers:

- Power-Open/Spring-Close - Page 19
- Power-Close/Spring-Open - Page 20
- Power-Open/Power-Close (Floating) - Page 20
- Mixing Box - Page 21
- Dual Duct - Page 23

Modulating Damper:

- Single Damper: 0[2]-10 VDC - Page 21
- Mixing Box: 0[2]-10 VDC - Page 22
- Dual Duct: 0[2]-10 VDC - Page 24

24V AC Power-Open/Spring-Close (Two-Position Damper Actuator)

The zone thermostat sends 24V AC from [Y] to power the damper open for heating, cooling, and ventilation cycles. When 24V AC is removed, the dampers' actuator springs closed.

Note: As shown in the diagram, install a discharge air sensor to ensure proper damper operation. Refer to page 16 for detailed accessory wiring diagrams.

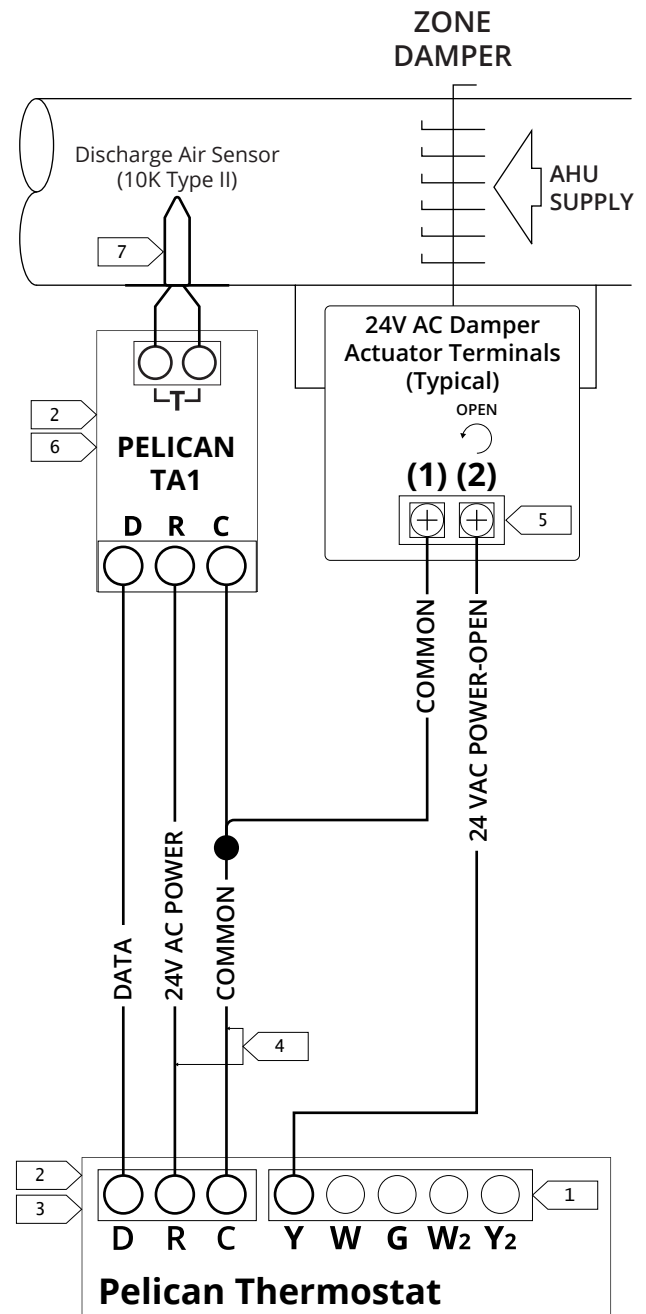

Wiring - Damper Actuators

24V AC Power-Close/Spring-Open (Two-Position Damper Actuator)

The zone thermostat sends 24V AC from [Y2] to power the damper closed. When 24V AC is removed, the dampers' actuator springs open for heating, cooling, and ventilation cycles.

Note: As shown in the diagram, install a discharge air sensor to ensure proper damper operation. Refer to page 16 for detailed accessory wiring diagrams.

24V AC Power-Open/Power-Close (Floating Damper Actuator)

The zone thermostat sends 24V AC from [Y] to open the damper for heating, cooling, and ventilation cycles. When 24V AC is sent from [Y2] the damper closes.

Note: As shown in the diagram, install a discharge air sensor to ensure proper damper operation. Refer to page 16 for detailed accessory wiring diagrams.

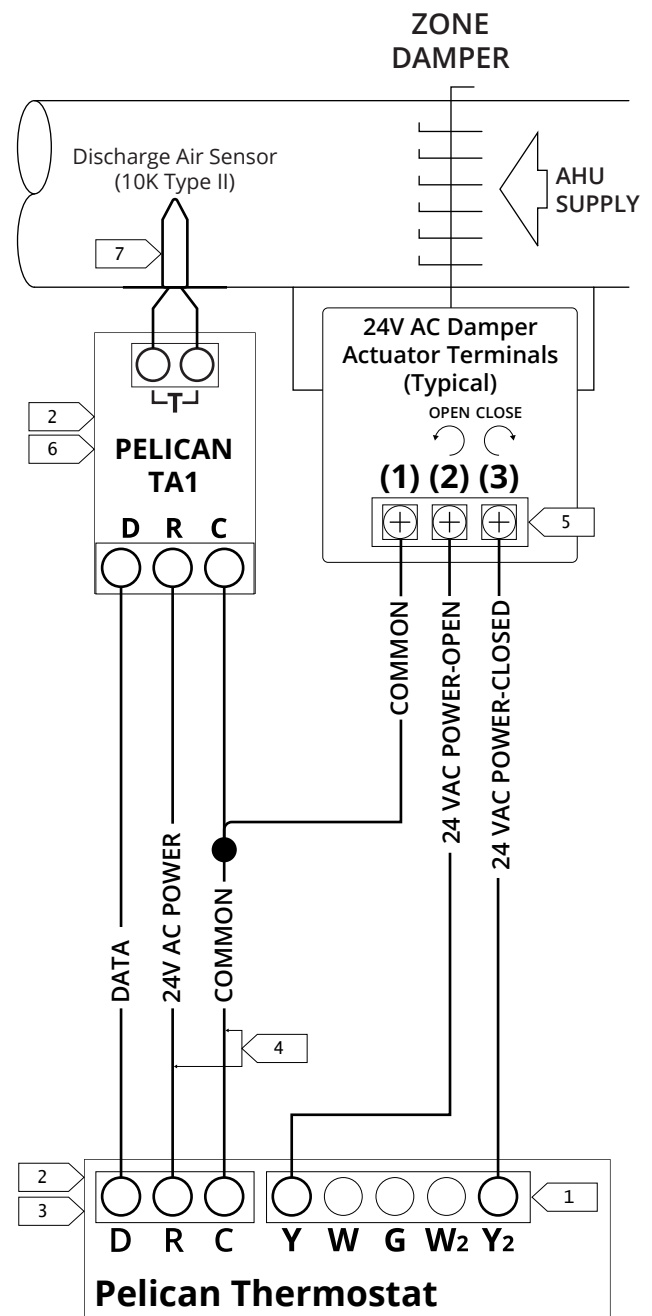
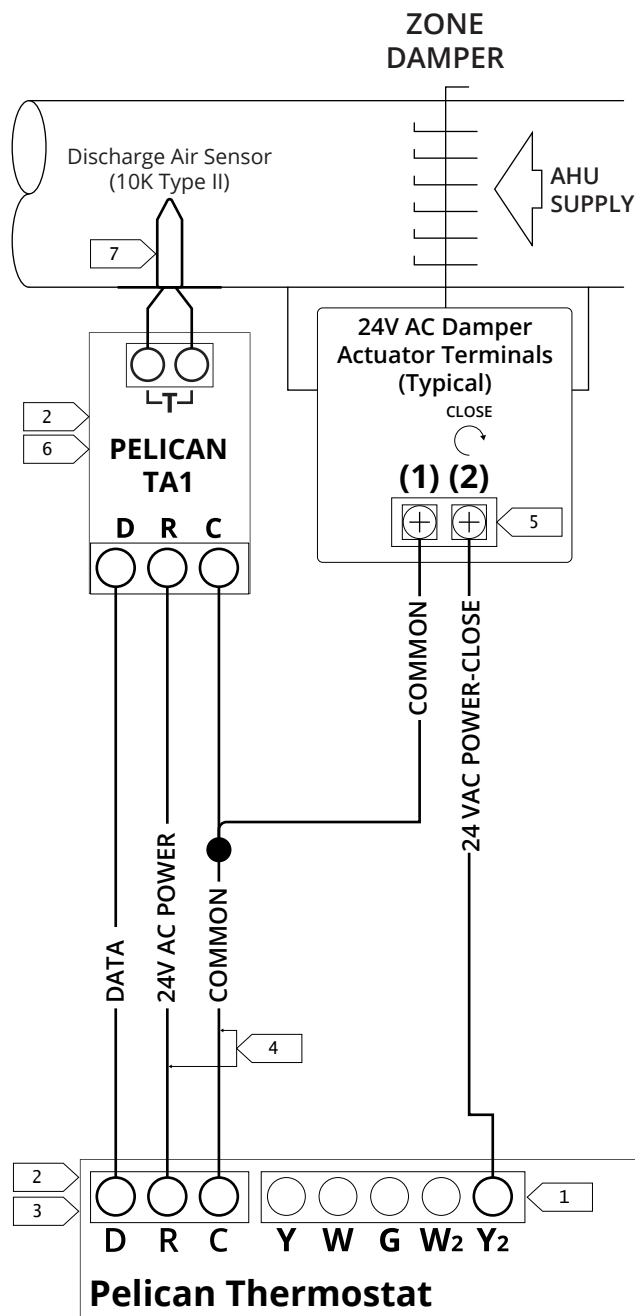

Wiring - Damper Actuators

0(2) – 10 VDC Modulating Damper (Variable Damper Actuator)

The PEARL uses DC voltage to adjust the damper position. Voltage settings for open and closed positions are configured through the Pelican Connect app.

Note: As shown in the diagram, a discharge air sensor is required for proper damper operation. Refer to page 17 for detailed accessory wiring diagrams.

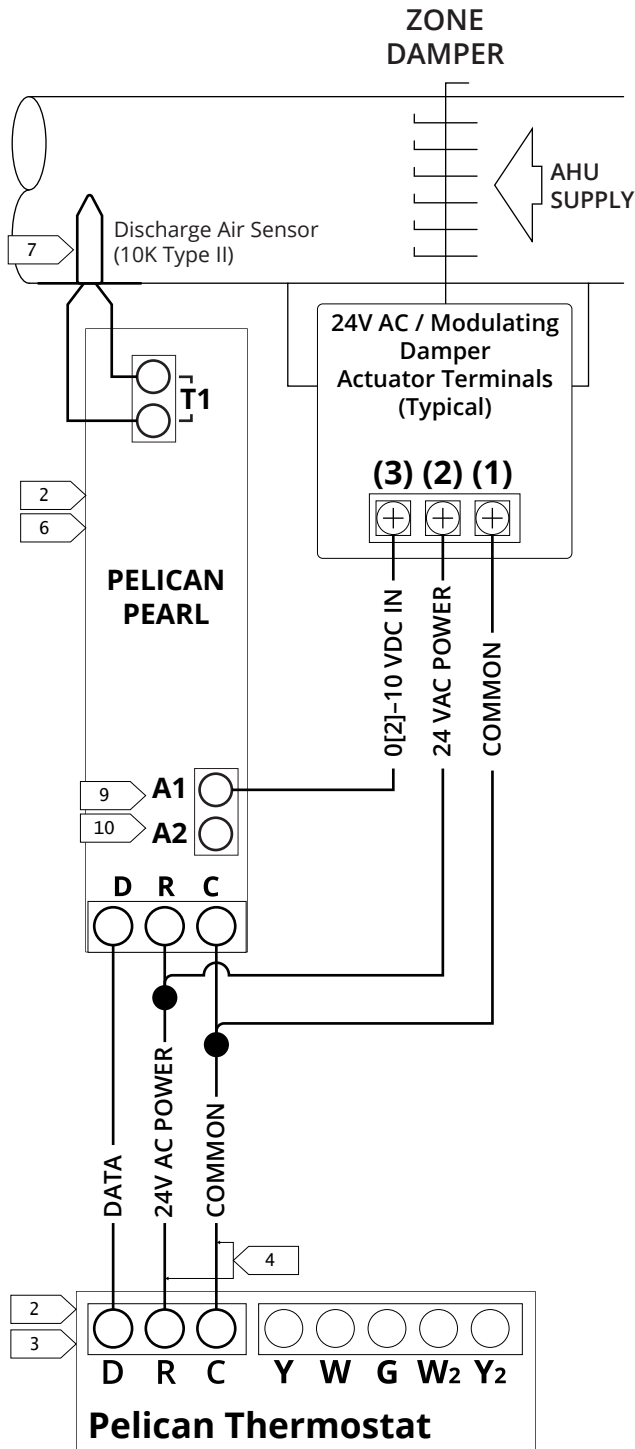

24V AC Mixing Box Actuator (Two-Position Damper Actuator)

The zone thermostat sends 24V AC from [Y] to rotate the damper to the cold deck. When 24V AC is sent from [Y2] the damper rotates to the hot deck. The dampers are linked and rotate in opposite directions of each other.

Note: As shown in the diagram, install a discharge air sensor to ensure proper damper operation. Refer to page 16 for detailed accessory wiring diagrams.

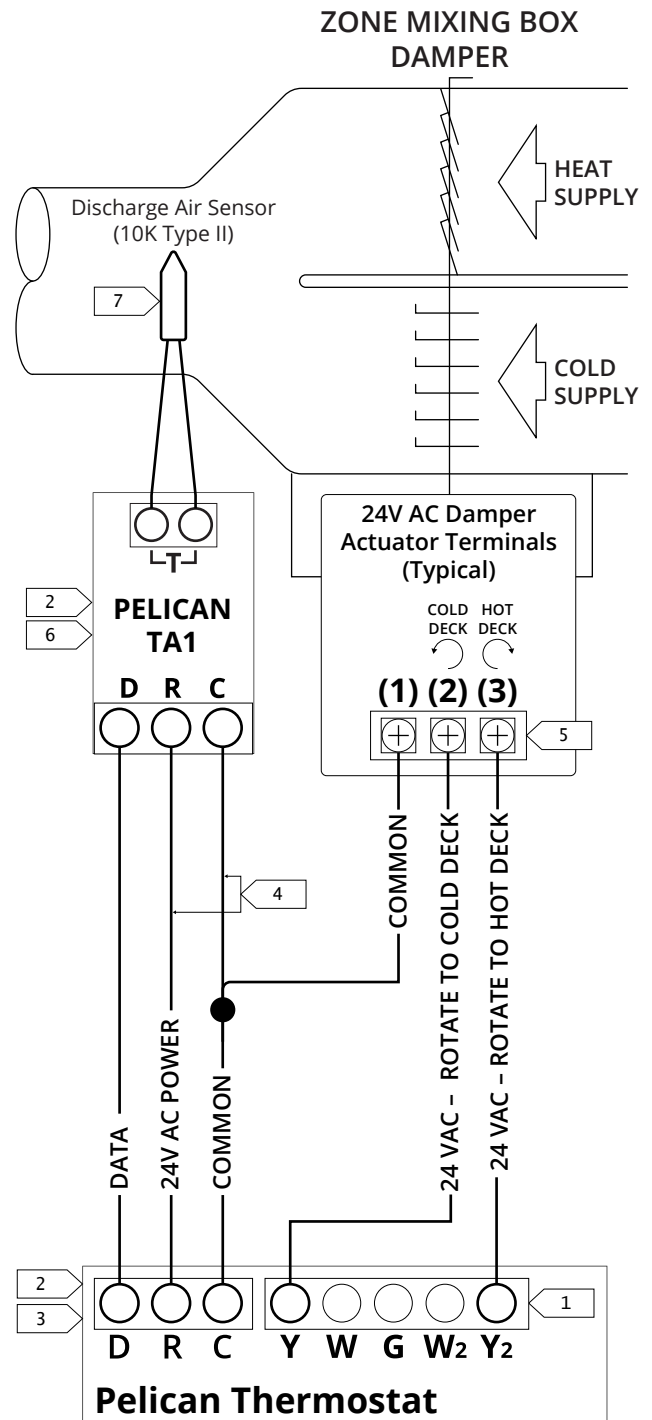

Wiring - Damper Actuators

0(2) – 10 VDC Mixing Box Modulating (Variable Damper Actuator)

The PEARL uses DC voltage to rotate the damper to either the hot or cold deck. Voltage settings for cold deck and hot deck positions are configured through the Pelican Connect app. The decks are linked and rotate in opposite directions.

Note: As shown in the diagram, a discharge air sensor is required for proper damper operation. Refer to page 17 for detailed accessory wiring diagrams.

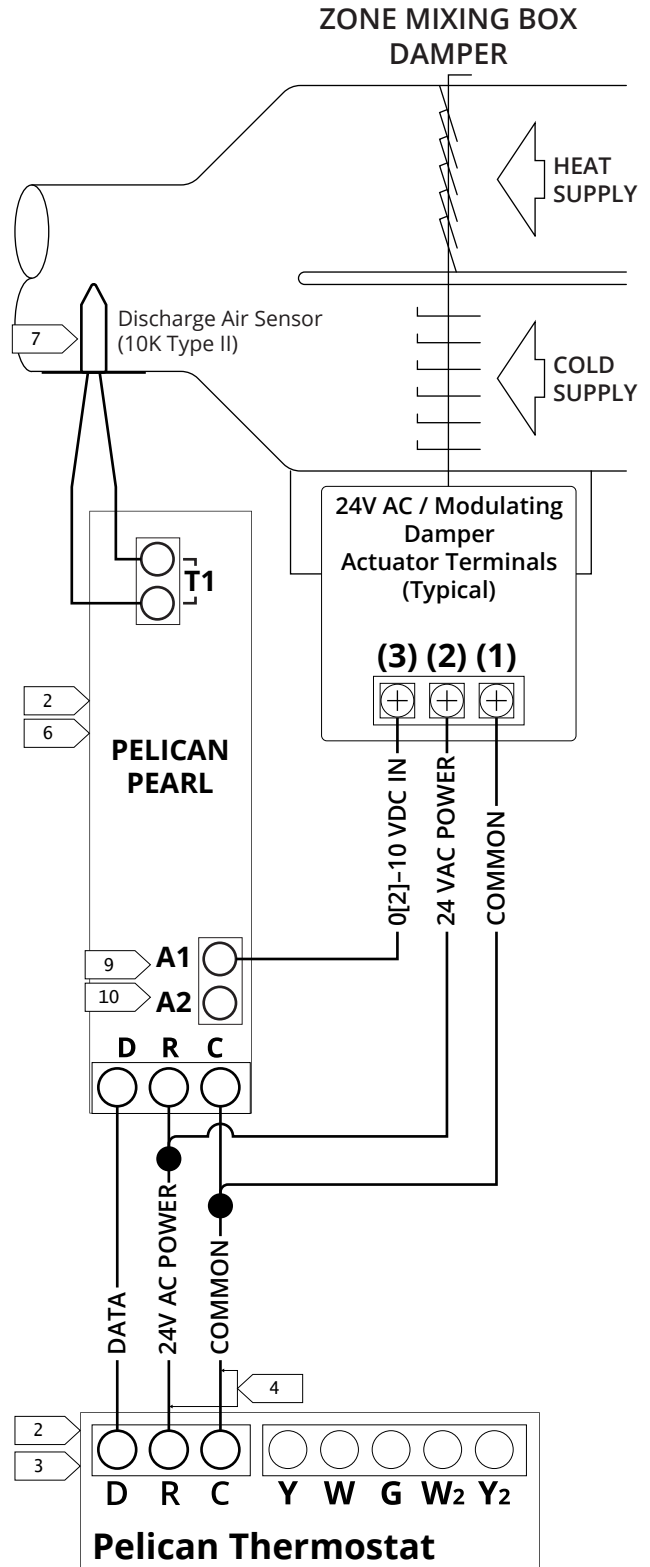

Wiring - Damper Actuators

24V AC Dual Duct Actuators (Two-Position or Floating Damper Actuators)

For dual duct applications, the thermostat adjusts the hot and cold decks as separate dampers, with each deck having its own actuator. The zone thermostat sends 24V AC from [Y] to open the cold damper for cooling and ventilation cycles. 24V AC is applied from [Y2] to close the cold deck damper. 24V AC from [W] is sent to open the hot damper for heating and ventilation/transfer air cycles. 24V AC is applied from [W2] to close the hot deck damper.

Note: As shown in the diagram, install a discharge air sensor to ensure proper damper operation. Refer to page 16 for detailed accessory wiring diagrams.

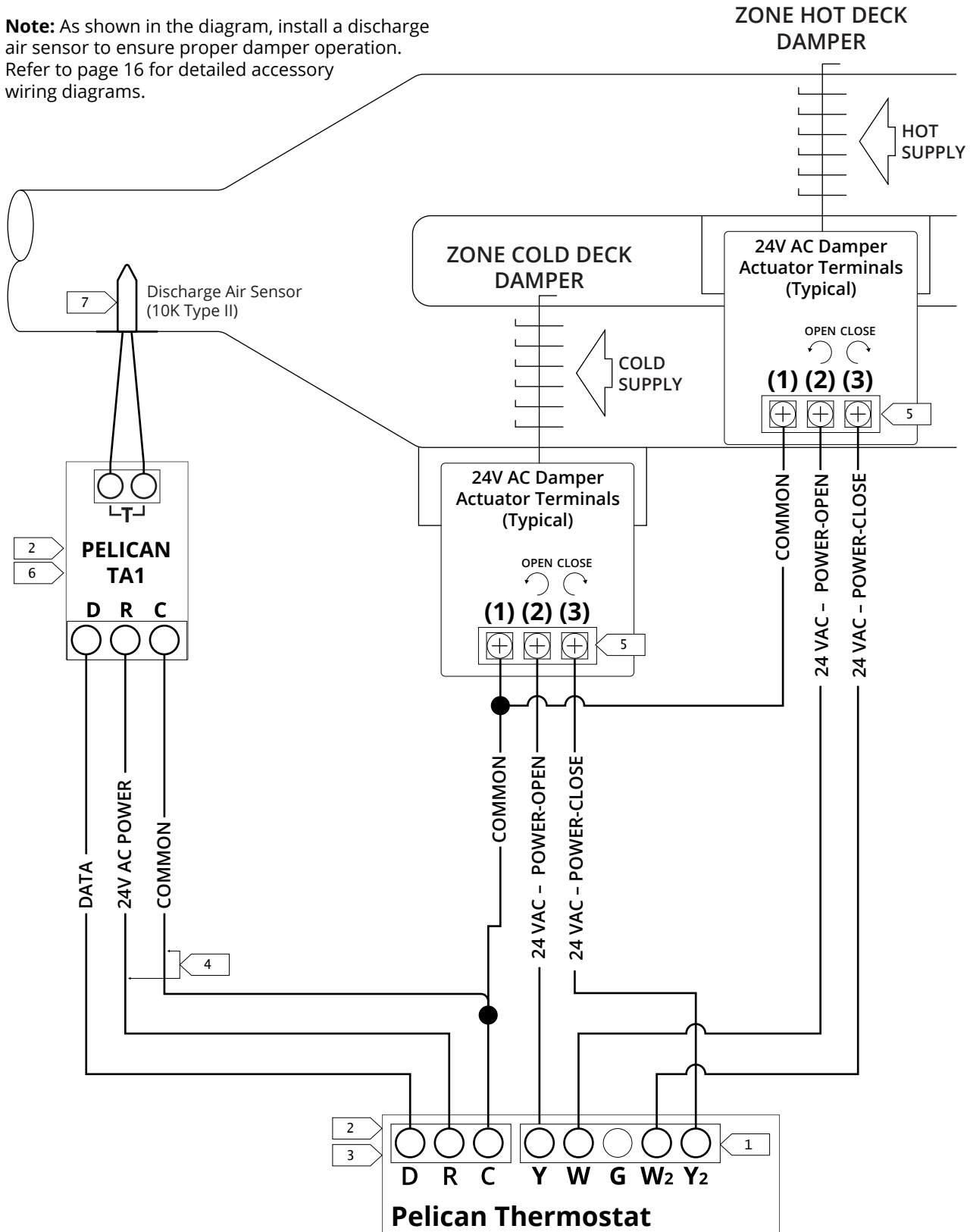

Wiring - Damper Actuators

0(2) – 10 VDC Dual Duct Modulating (Variable Damper Actuator)

For modulating dual duct applications, the thermostat adjusts the hot and cold decks as separate dampers, with each deck having its own actuator. The PEARL uses DC voltage to adjust each damper position independently. Voltage settings for open and closed positions are configured through the Pelican Connect app.

Note: As shown in the diagram, a discharge air sensor is required for proper damper operation. Refer to page 17 for detailed wiring accessory diagrams.

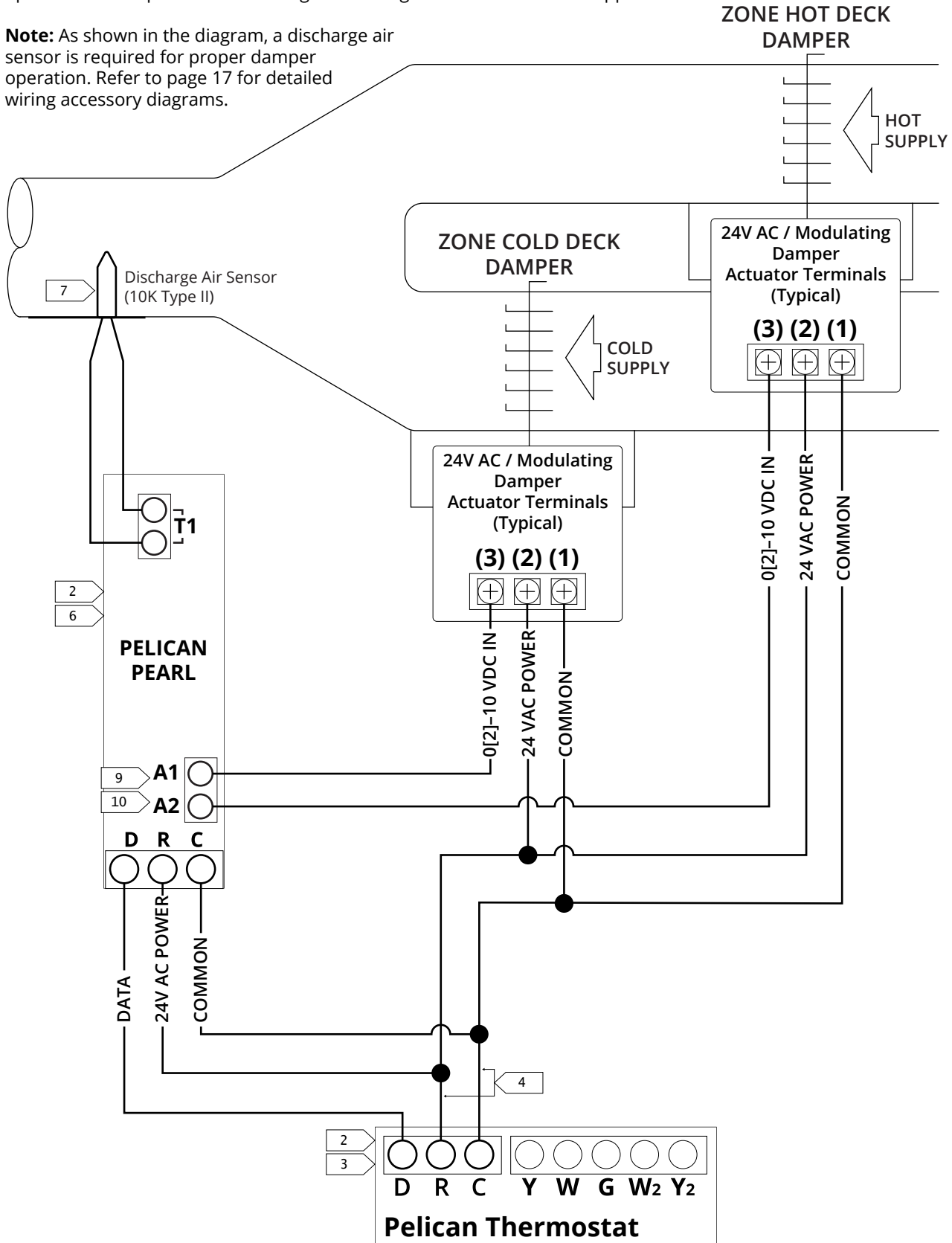

Wiring - Reheats

Pelican thermostats and accessories can be wired and configured to control a wide range of zone reheats. Refer to the "Installation Planning" diagrams on pages 6 to 12 for the most common applications. It is essential to follow the following wiring diagrams, as the controller's outputs are closely linked to their configured functions.

Verify proper mechanical operation before and after installation and ensure that all configurations are accurate for your installation.

For installations outside of these diagrams, stop what you are doing and contact Pelican support for further assistance.

Hot Water Reheat Valves:

- Power-Open/Spring-Close - Page 25
- Power-Close/Spring-Open - Page 26
- Floating: Power-Open/Power-Close - Page 26
- Modulating: 0[2]-10 VDC - Page 27

Electric Reheat:

- Start/Stop - Page 27
- Modulating SCR: 0[2]-10 VDC - Page 28

24V AC Power-Open/Spring-Close (Two-Position Reheat Actuator)

The zone thermostat sends 24V AC from [W] to power the reheat valve open for heating cycles. When 24V AC is removed, the reheat valve's actuator springs closed.

Note: As shown in the diagram, install a discharge air sensor to ensure proper reheat operation. Refer to page 16 for detailed accessory wiring diagrams.

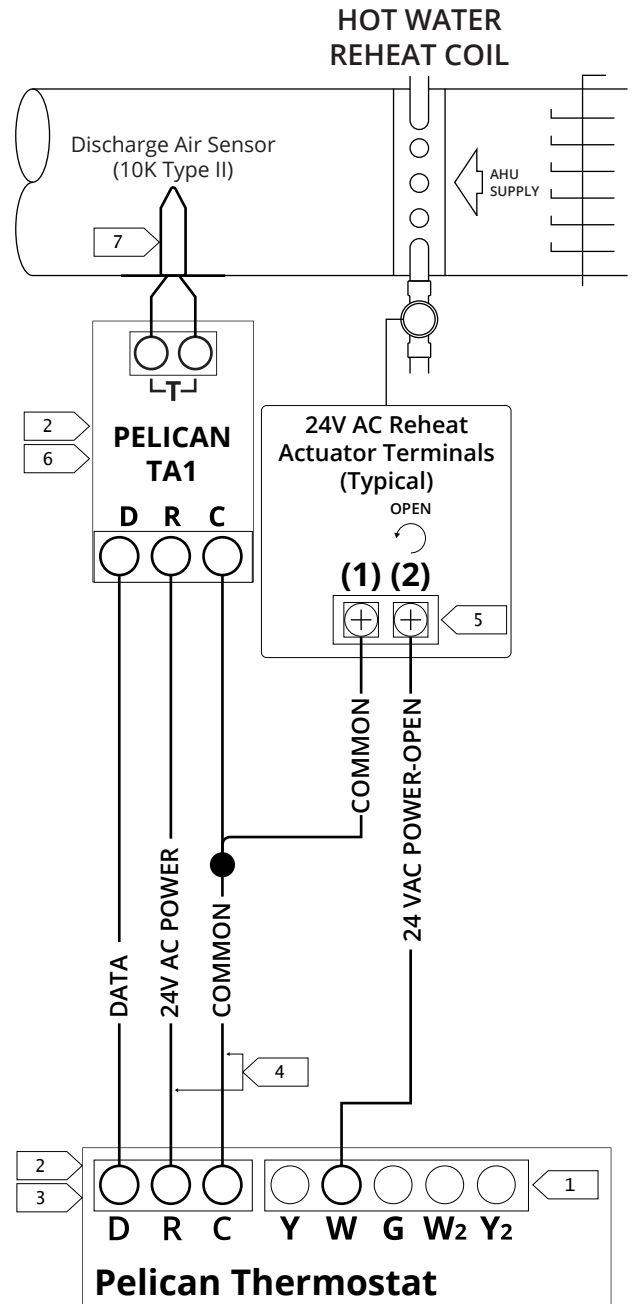

Wiring - Reheats

24V AC Power-Close/Spring-Open (Two-Position Reheat Actuator)

The zone thermostat sends 24V AC from [W2] to power the reheat valve closed. When 24V AC is removed, the reheat valves' actuator springs open for heating cycles.

Note: As shown in the diagram, install a discharge air sensor to ensure proper reheat operation. Refer to page 16 for detailed accessory wiring diagrams.

24V AC Power-Open/Power-Close (Floating Reheat Actuator)

The zone thermostat sends 24V AC from [W] to open the reheat. When 24V AC is sent from [W2] the reheat closes.

Note: As shown in the diagram, install a discharge air sensor to ensure proper reheat operation. Refer to page 16 for detailed accessory wiring diagrams.

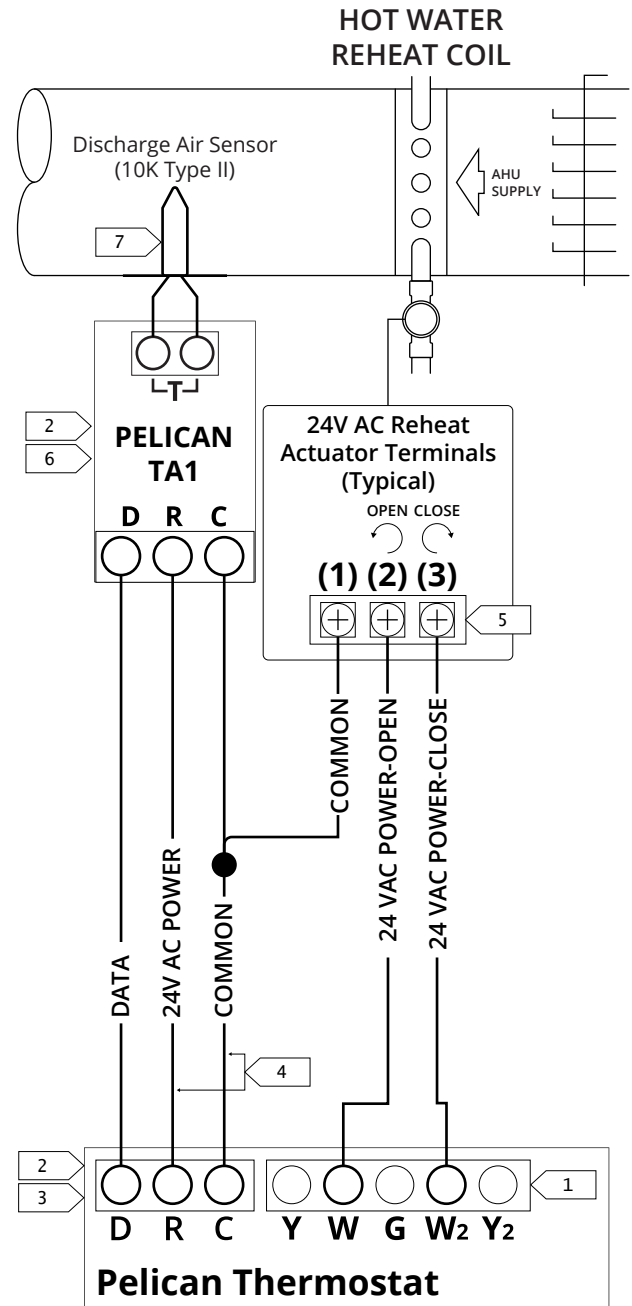
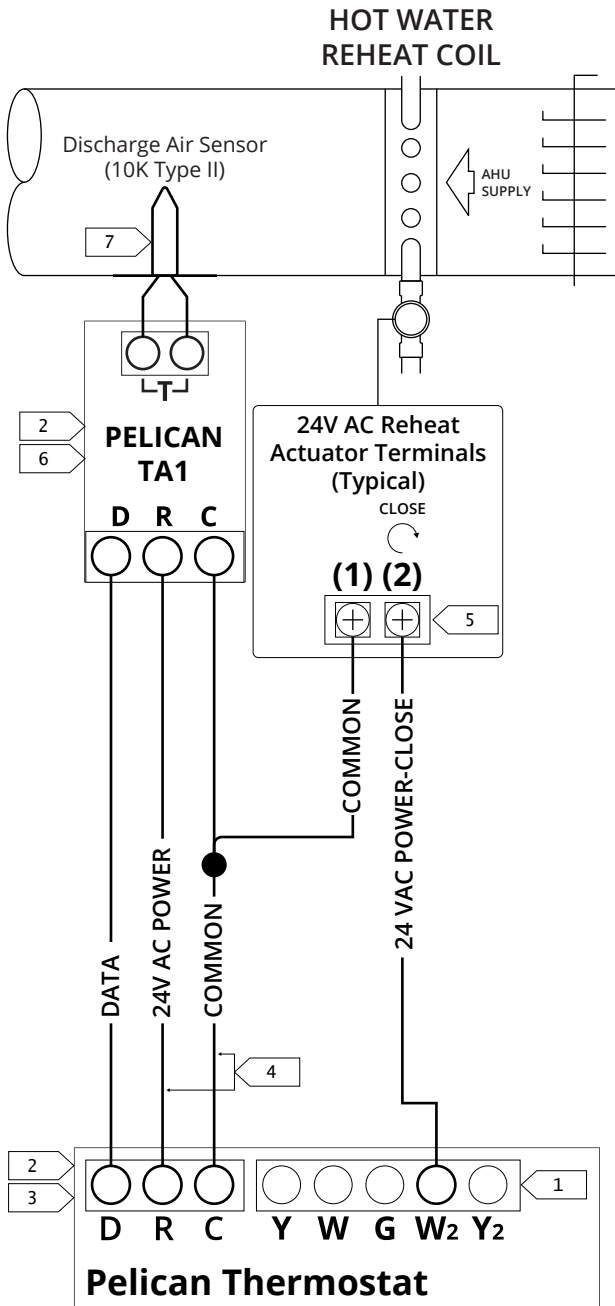

Wiring - Reheats

0(2) – 10 VDC Modulating Signal (Variable Reheat Actuator)

The PEARL uses DC voltage to adjust the reheat valve position. Voltage settings for open and closed positions are configured through the Pelican Connect app.

Note: As shown in the diagram, a discharge air sensor is required for proper reheat operation. Refer to page 17 for detailed wiring diagrams of accessory.

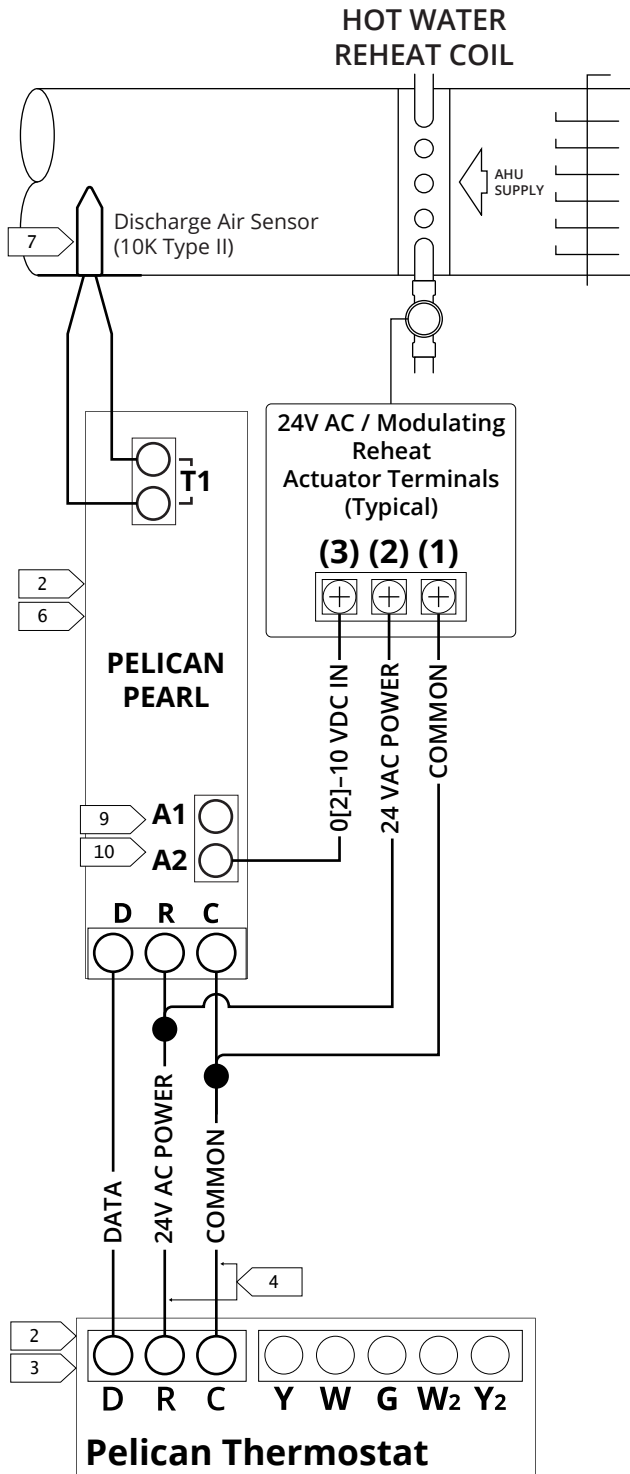

Electric Reheat (Start/Stop)

The zone thermostat sends 24V AC from [W] to enable the electric reheat during heating cycles. When 24V AC is removed, the reheat is disabled.

Note: As shown in the diagram, install a discharge air sensor to ensure proper reheat operation. Refer to page 16 for detailed accessory wiring diagrams.

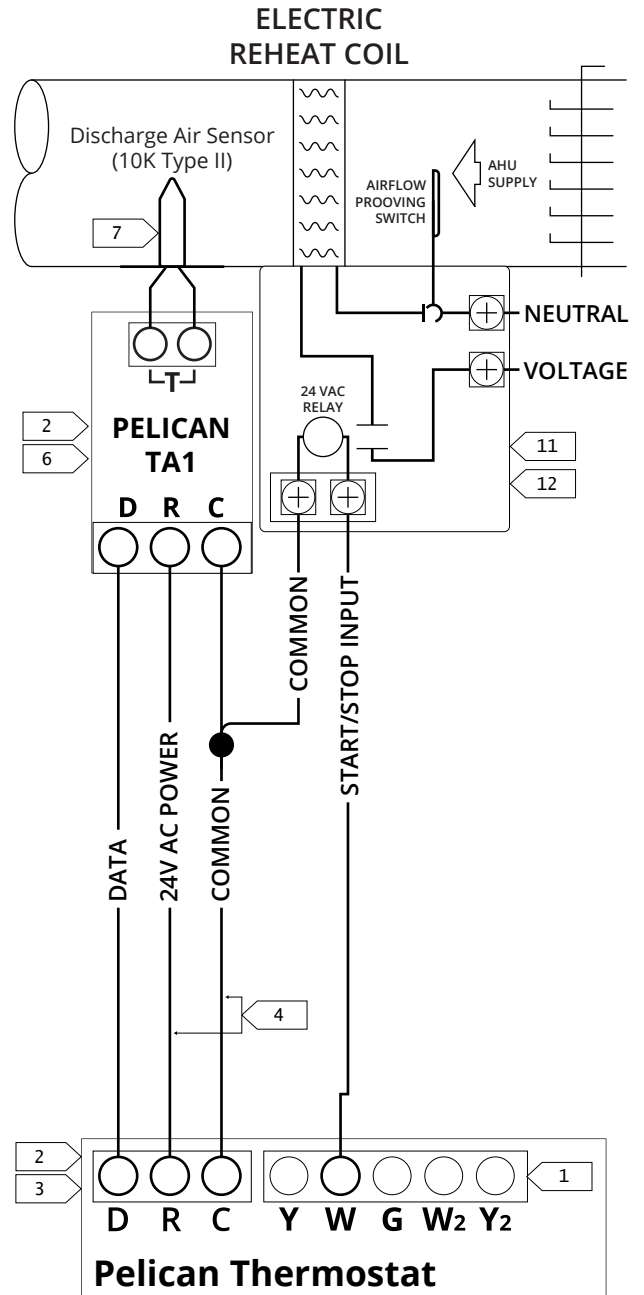

Wiring - Reheats

0(2) – 10 VDC Modulating Electric Reheat (Start/Stop & Variable Control)

The zone thermostat sends 24V AC from [W] to enable the electric reheat during heating cycles. When 24V AC is removed, the reheat is disabled.

The PEARL uses DC voltage to adjust the reheat output. Voltage settings for maximum and minimum output are configured through the Pelican Connect app.

Note: As shown in the diagram, a discharge air sensor is required for proper reheat operation. Refer to page 17 for detailed accessory wiring diagrams.

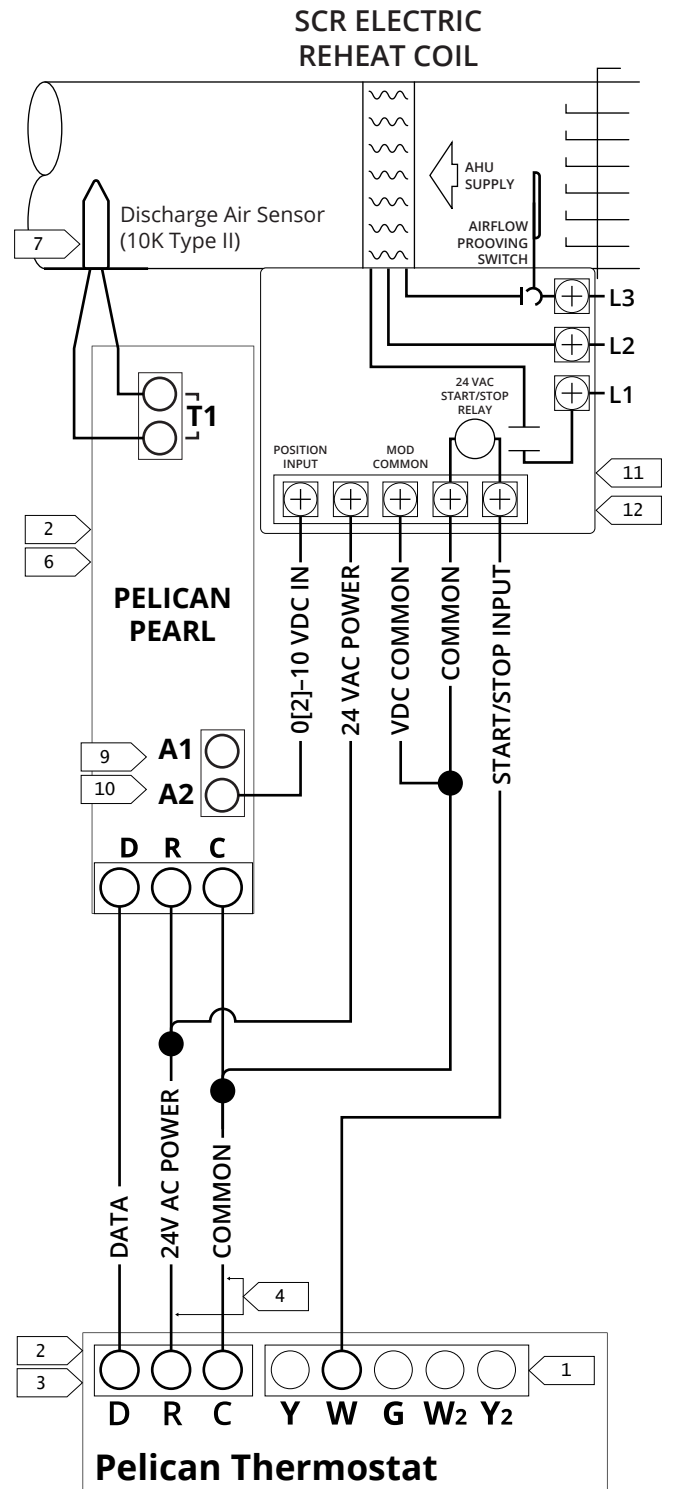

Wiring - Fan Powered Boxes

Pelican thermostats and accessories can be wired and configured to control a Series or Parallel fan powered box. Refer to the "Installation Planning - Fan Powered Boxes" diagrams on page 10 for the most common applications. It is essential to follow the following wiring diagrams, as the controller's outputs are closely linked to their configured functions.

Verify proper mechanical operation before and after installation and ensure that all configurations are accurate for your installation.

For installations outside of these diagrams, stop what you are doing and contact Pelican support for further assistance.

Terminal Fan Powered Boxes:

- Series Fan - Page 29
- Parallel Fan - Page 30

Series Fan Powered Terminal Box

The zone thermostat sends 24V AC from [G] to enable the terminal fan during cooling, heating, and ventilation cycles. When 24V AC is removed, the fan is disabled.

The primary damper is only open for cooling and ventilation cycles, while reheat uses the induced air duct.

Note: As shown in the diagram, install a discharge air sensor to ensure proper damper operation. Refer to page 16 for detailed accessory wiring diagrams.

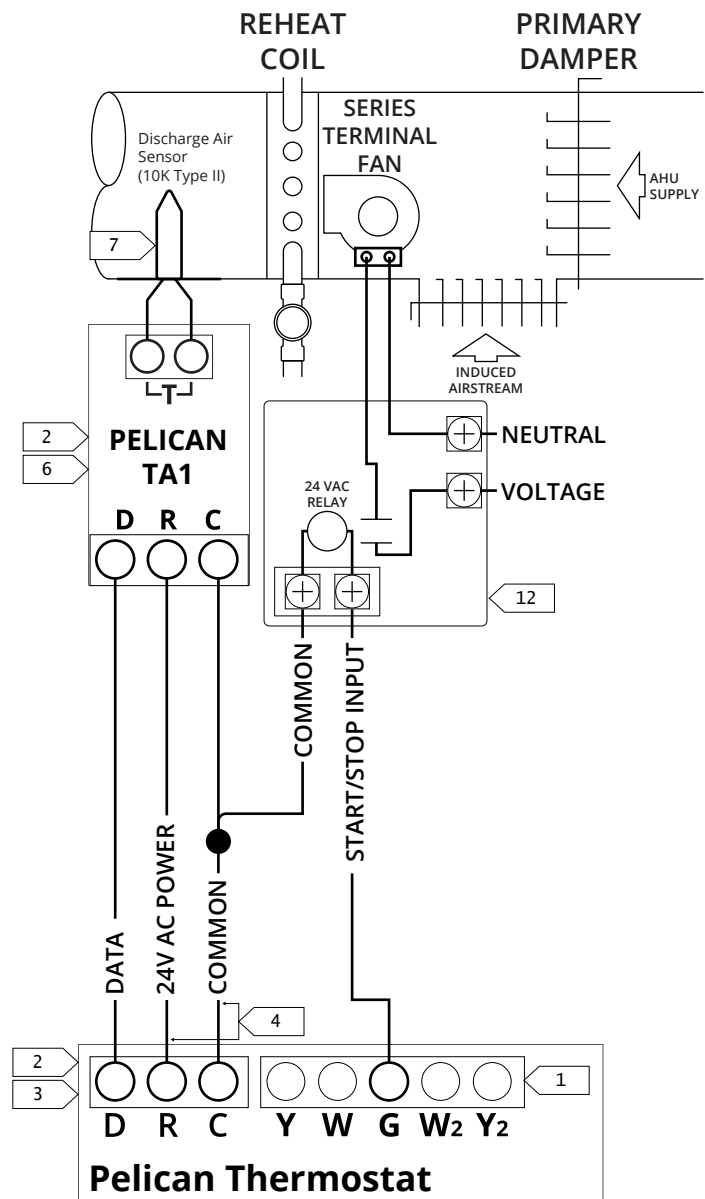

Parallel Fan Powered Terminal Box

The zone thermostat sends 24V AC from [G] to enable the terminal fan during heating, and ventilation cycles. When 24V AC is removed, the fan is disabled.

The primary damper is only open for cooling and ventilation cycles, while reheat uses the induced air duct.

Note: As shown in the diagram, install a discharge air sensor to ensure proper damper operation. Refer to page 16 for detailed accessory wiring diagrams.

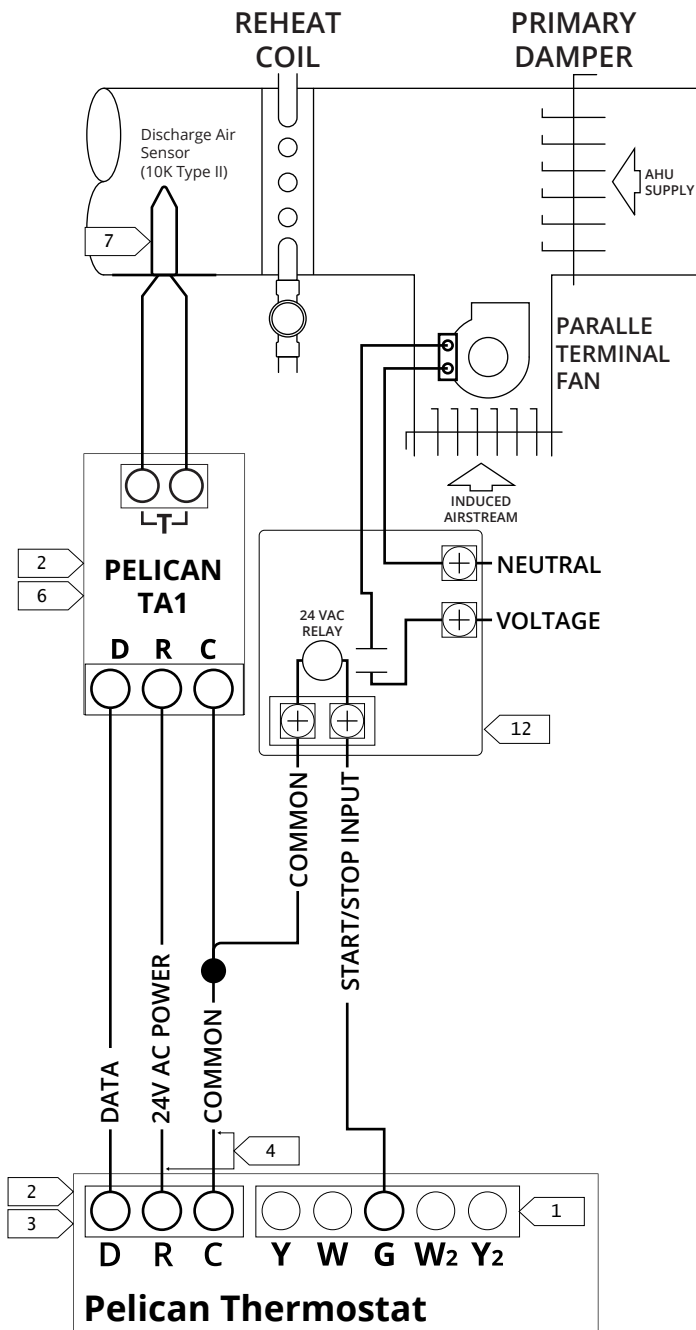

Notes

- 1 Outputs are 24V AC latching relays rated for max 2 amps continuous load.
- 2 All wire to be installed in accordance with local electrical codes. Only one wire per terminal. Use wire nuts where needed.
- 3 We recommend using 18 gauge unshielded thermostat wire.
- 4 24V AC Class 2 power only. Reference page 18 for instructions on how to power the controller.
- 5 Actuator power to be 24V AC and to not exceed 2A running. Size power source to accommodate controller and actuator(s) at required VA when operating. Otherwise use isolation relays where actuators are outside of allowances.
- 6 Install a Pelican TA1 (sold separately) for discharge temperature detection for damper and reheat proving. Wire the TA1's R, C, D power and communication terminals to the zone thermostat's R, C, D power and communication terminals.
- 7 A 10K Type 2 thermistor (sold separately) is required for this application.
- 8 Follow equipment manufacturer's installation and operation manual for power requirements. Power is separate from power to controller since they are isolated.
- 9 Analog outputs are 0[2]—10V DC.
- 10 Either A1 or A2 can be configured to control the modulating damper or modulating reheat. The diagram shows the most common wiring.
- 11 Air proving switch to be installed as outlined by electric reheat manufacturer requirements.
- 12 Drawing represents a common isolation electrically controlled switch used to isolate the high voltage power circuits from the low voltage control signals. Electrical switches are most commonly 2-phase or 3-phase and must remain isolated from Pelican controller.

Before Start-up

To configure the controller(s), they must be connected to the Pelican wireless network and the network must have a Pelican gateway to connect everything to the Internet.

Before start-up, verify the following are installed and wired to the thermostat:

Required. . .	Provides. . .	Reference Page. . .
Damper Control – The Pelican controller(s) are wired to open, close, and/or modulate the zone damper.	<ul style="list-style-type: none"> Allows or restricts air into zone. Airflow management. Historical Data Log. 	Mech Diagrams: 7 – 12 Wiring Diagrams: 19 – 24 Configurations: 35 – 39 Sequences: 40 – 46
Reheat Control (as required) – The Pelican controller(s) are wired to open, close, and/or modulate the zone reheat.	<ul style="list-style-type: none"> Reheat discharge air into zone. Proof of reheat active. Historical Data Log. 	Mech Diagrams: 7 – 12 Wiring Diagrams: 25 – 28 Configurations: 35 – 39 Sequences: 40 – 46
Discharge Temperature Sensor – The Pelican controller(s) are wired to a 10K Type 2 thermistor installed after the damper and reheat and is reading accurate temperatures.	<ul style="list-style-type: none"> Proof of damper operation. Reheat modulating reset (as required). Historical Data Log. 	Mech Diagrams: 7 – 12 Wiring Diagrams: 19 – 30 Configurations: 35 – 39 Sequences: 40 – 46
Pelican thermostat – The thermostat is properly mounted in the room to read accurate zone space temperature, humidity, and CO2 levels; as required for your application. Follow the installation guide provided with the thermostat for specific thermostat mounting and installation instructions.	<ul style="list-style-type: none"> Room temperature. Set-point control. Logic to accessories controlling dampers, reheats, terminal fans. Demand Ventilation (as required) Humidity management. Historical Data Log. 	Mech Diagrams: 7 – 12 Wiring Diagram: 14 Configurations: 35 – 39 Sequences: 40 – 46

Start-Up: Attached Thermostat Display to Back Plate

Before attaching the display, write down the serial number displayed on the screen. This number will be needed when configuring the thermostat.

Align the display with the back plate's alignment pins, then press it into the back plate until it clicks into place.

Turn on the power to the HVAC equipment connected to the thermostat.

If your Pelican thermostat does not power on, refer to page 33 for troubleshooting.

For instructions on configuring the thermostat, reference "Start-Up - Setting Configurations" on page 35.

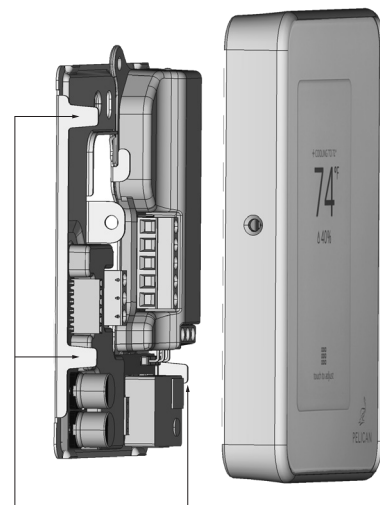

there are three (3) alignment pins found on the left and right sides of the base plate.

Optional: Tamper Resistant Lock

The thermostat has an internal locking mechanism that secures the display to the back plate, preventing unauthorized access to the power and thermostat wires.

To engage the lock, assemble the thermostat and insert a 1/8" flat-head screwdriver into the hole on the left side of the thermostat. Push in slightly and turn 1/4 turn clockwise until it reaches the stop. Then, remove the screwdriver.

To disengage the lock, insert a 1/8" flat-head screwdriver into the same hole and turn 1/4 turn counter-clockwise until it reaches the stop. Remove the screwdriver.

Do NOT attempt to force the display off the back plate, as this could cause damage.

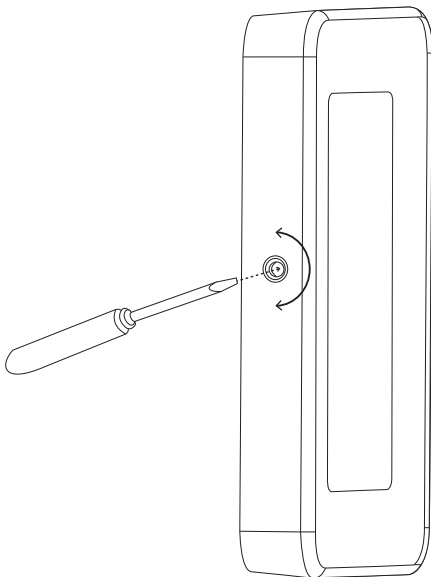

Power and Connectivity Troubleshooting

If the Pelican thermostat or accessories do not power on, check the following:

1. Check that all wires are properly inserted into the terminal blocks at the thermostat and its accessories. Lightly pull on the wires to make sure they are not loose.
2. Use a multi-meter to ensure that 24V AC power is being supplied by the transformer. If 24V AC is not found, check that the master power has been turned back on for the transformer or verify that the electrical breaker has not tripped. If the breaker has tripped contact a Licensed Professional to assist, otherwise damage can occur to the equipment or you can get hurt.
3. Use a multi-meter to ensure that 24V AC power is found at the thermostat. If 24V AC was not found, but is found at the transformer, check for loose or spliced wires.
4. If you co-located the Wiring Module, installed a TA1 and/or installed the PEARL, use a multi-meter to ensure that 24V AC power is found at each accessory. Check that the (R), (C), and (D) wires are properly connected between the accessories and the thermostat. Verify that (R) and (C) are not accidentally installed in reverse, since the device may power-on, but communication will not establish.

If the thermostat or its accessories still do not power On, contact Pelican technical support for further assistance at 888.512.0490.

If the Pelican thermostat does not show up on the Pelican App, check the following:

1. Check the thermostat upper right hand corner.

If you see this symbol  then the thermostat is unable to connect to your Pelican Wireless Mesh Network.

- Finish installing all your other Pelican thermostats and/or devices.

- Verify your Pelican thermostat is not in a metal enclosure and that there are no metal structures/objects surrounding it. Wireless can NOT communicate through metal.

2. If you see this symbol  then the thermostat is connected to your Pelican Wireless Mesh Network, but your Pelican Gateway is unable to reach the Internet.

- Check your Pelican Gateway to verify it is installed, powered on, and has Internet connection.

If you are unable to get the thermostat to connect to the wireless mesh network or Internet, contact Pelican technical support for further assistance at 888.512.0490.

Setting Configurations

All thermostat and accessory configurations are set through the Pelican Connect app:

Step 1: Locate the thermostat's Serial Number on the display or in the INFO screen of the thermostat.

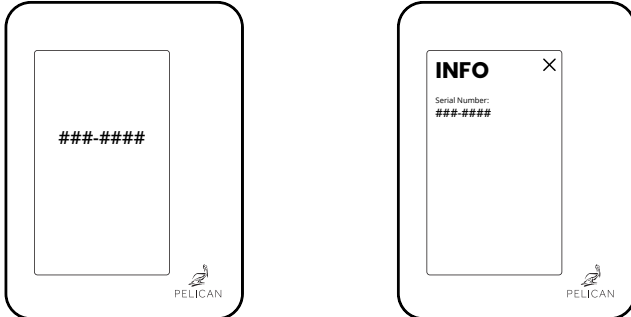

Step 2: On a computer or phone log into the Pelican Connect app. At the top under Notifications, there will be a selectable new thermostat with a matching serial number. If there is no notification, reference “Power and Connectivity Troubleshooting” on the previous page. You can also check the Admin section of the app and see if under Thermostat Configurations there is a matching device serial number.

NOTE: Pelican devices automatically connect to the web-app via the Pelican wireless mesh network and Pelican Gateway. There is no need to manually “add” a device to an existing Pelican web-app.

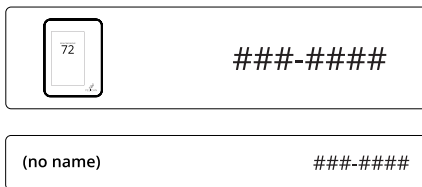

Step 3: In the thermostat's configuration settings, enable and set the correct configurations based on the equipment the controller(s) are wired to control. Reference “ Configurations” on pages 35 to 39.

For device operations, reference “Sequence of Operations” starting on page 40.

IMPORTANT: If not already installed, a Pelican zone coordinator must be installed to be able to configure a Pelican thermostat as a zone damper controller.

You will link the thermostat to its zone coordinator in the thermostat configuration page.

IMPORTANT: NEVER wire any zone thermostat or its accessory [D] terminals to the zone coordinator! This will create communication issues and the system will not operate.

Configurations

Thermostat and accessory configurations are set through the Pelican Connect app. For the thermostats to be configured, they must be connected to the Pelican wireless network and the network must have an active Pelican gateway.

Configurations must match the sequences for the equipment the controllers are wired to. Reviewing each configuration is crucial for proper sequencing. Incorrect configurations can negatively impact the performance of the equipment.

The controllers will not properly operate the equipment if the following conditions are true:

- The thermostat and accessories are not correctly wired to the equipment they are controlling.
- Temperature sensors are not installed correctly, are not properly wired to the thermostat, or are detecting inaccurate temperatures.
- A zone coordinator is not installed and therefore the thermostats cannot be configured as zone damper controllers.
- The thermostats have not been linked to or are unable to communicate with their zone coordinator over the wireless network.
- There are equipment malfunctions or other mechanical issues that need to be fixed.

IMPORTANT

This section is for reference only. Pelican thermostats and accessories receive regular updates and additional configuration options that may not be included in this guide. For further assistance or help with specific application needs, contact Pelican engineering support.

Navigating to the Configurations:

1. Login to the Pelican Connect app.
2. Select Admin.
3. Select Thermostat Configurations.
4. Select the thermostat being configured.

Table Key:

(D) = Default.
 (R) = Range.
 (advanced) = Advanced configurations are provided but with limited access.

Identification

Allows for custom identifiers and notes for the thermostat, the zone boxes being controlled, and any other relevant information about the system.

Configuration Name/Description	Settings/Range
Name – Allows for a unique name to be assigned to the thermostat. Normally this would be the room's name or number. Examples: Room 101, Office 200, Classroom 24B.	(D) (no name)
Description – Allows notes to be inputted for tracking information unique to this thermostat and/or the system this thermostat is wired to. The first line of this entry shows as small text under the thermostat's name on the main control page. Normally the first line would be the zone box's identification number. Examples: Zone 01, VAV-01, TB-02, VVT-05	(D) (empty)

Thermostat Settings

Set the thermostat as a zone damper controller.

Configuration Name/Description	Settings/Range
System Type – Set to Zone Damper since this thermostat will use the zone damper sequence of operations.	(D) Conventional Heat Pump Zone Damper ¹ (A) Dual Duct Damper ²
Zone Controller – Select the zone coordinator which this thermostat gets central air from.	(D) (blank) <i>All installed zone coordinators will appear as selectable options.</i>
Heat Zone Controller (advanced) – Select the zone coordinator which this thermostat gets central heat from.	(D) (blank) <i>All installed zone coordinators will appear as selectable options.</i>

¹Thermostats can only be configured to Zone Damper if there is a zone coordinator installed and connected to the Pelican wireless network.

²Dual Duct Damper will only show as a configuration if released by Pelican Technical Support. Contact Pelican support at 888.512.0490 or email support@pelicanwireless.com for further assistance.

Configurations

Temperature Settings

Adjust temperature set-point ranges and sensor usage.

Configuration Name/Description	Settings/Range
Heat Range – Sets the “Heat To” set-point range allowance. Restricting how high the heat can be set is important for operation and energy efficiency.	(D) 56°F to 76°F (R) -20°F to 180°F
Cool Range – Sets the “Cool To” set-point range allowance. Restrictions to how low the cool can be set is important for operation and energy efficiency.	(D) 66°F to 86°F (R) -20°F to 180°F
Temp Sensor¹ – Disables or enables the thermostats internal temperature sensor.	(D) Enabled Disabled
Temp Display – Sets which units the temperature will be displayed on the thermostat.	(D) Fahrenheit Celsius
CO₂ Ventilation² – Sets at which CO ₂ parts per million (PPM) demand ventilation will be active.	(D) 800 (R) 400 - 2000
Display CO₂² – Disable or enable if the thermostat displays its CO ₂ reading in its Info screen.	(D) Enabled Disabled

¹Configuration appears if there is an external temperature sensor wired to the thermostat. Reference “Configurations - Input Sensor” on page 38 for more information.

²Configuration appears for thermostats with internal Carbon Dioxide (CO₂) sensors. For sequence of operation information reference “Sequence of Operations - Demand Controlled Ventilation” on page 45.

Thermostat Operation

Adjust sequences for maintaining room temperature.

Configuration Name/Description	Settings/Range
Cycles Per Hour – Sets a target cycle rate for the thermostat.	(D) 4 (R) 1 to 6
Anticipation Degrees – Adjusts the deviation above or below set-point before starting a purge cycle.	(D) 0.1°F (R) 0.0°F to 0.5°F
Calibration Degrees – Adjusts the thermostats internal temperature reading.	(D) 0°F (R) -2.0°F to 2.0°F
Satisfy Cooling with Aggressive¹ (advanced) – Disables or enables if aggressive cooling remains advertised when the zone temperature moves to within 1.0°F of the cool set-point.	(D) Yes No

¹Satisfy Cooling with Aggressive set to YES: If the zone temperature transitions from moderate cooling demand to aggressive cooling demand and then back to moderate cooling demand it will continue to advertise aggressive cooling demand to satisfy its cooling demand.

Satisfy Cooling With Aggressive set to NO: If the zone temperature transitions from aggressive cooling demand to moderate cooling demand it will advertise moderate cooling demand and not remain in aggressive.

Damper Settings

Configure what type of zone damper and reheat the thermostat is controlling.

Configuration Name/Description	Settings/Range
Damper Type¹ – Enables the correct outputs for the type of damper actuator being controlled.	(D) None Open/Close Floating Mixing Box Modulating ² Modulating Mixing Box ²
Fan Control (advanced) – Enables the control sequence for a Parallel or Series terminal fan powered box.	(D) None Parallel Series
Dump Zone (advanced) – Enables intelligent dumping for capacity management sequences.	(D) Limited No Yes

¹For Dual Duct applications, separate configurations for the cold deck damper and hot deck damper control types will be available. Contact Pelican Technical Support if feature is not enabled for your Pelican solution.

²Modulating options will automatically appear only if a PEARL is wired to the thermostat.

Configurations

Damper Settings Continued...

Floating Damper Configurations:	
Actuator Travel Time – Sets how many seconds it takes to rotate the damper from full closed to full open.	(D) (blank) (R) 1 to 160
Ventilation Damper Position – Sets the position to rotate the damper to during ventilation cycles.	(D) (blank) (R) 0% to 100%
Maximum Damper Position – Set the position to rotate the damper to during heating, cooling, and reheat cycles.	(D) 100% (R) 0% to 100%
Modulating Damper Configurations ¹ :	
Damper Signal Output – Sets which analog output is used for damper modulation.	(D) A1 A2
Damper Actuator Voltages – Sets the volt [DC] range for the modulating damper.	Open ² : (D) 10.0V DC (R) 0.0 to 10.0 Closed ³ : (D) 2.0V DC (R) 0.0 to 10.0

¹Modulating Damper Configurations will automatically appear only if a PEARL is wired to the thermostat and if the Damper Type is set to one of the modulating options.

²For mixing box applications, this will be labeled “Cold” which will be the output voltage to rotate towards the cold deck.

³For mixing box applications, this will be labeled “Heat” which will be the output voltage to rotate towards the hot deck.

Economizer (turn OFF)

When a PEARL is connected to a thermostat, this configuration option appears. Make sure to turn OFF the economizer sequences, as they are not used in damper control operations.

Variable Speed Fan

When a PEARL is connected to a thermostat, this option appears. It is rarely used in damper control but can control a modulating fan terminal box. The PEARL's (A2) output regulates fan speed, ranging from 0.0 VDC (0%) to 10.0 VDC (100%)

Configuration Name/Description	Settings/Range
Cool Fan Speed – Sets the fan speed during moderate cooling cycles.	(D) 70% 0% to 100%
Cooling Speed - Stage 2 – Sets the fan speed during aggressive cooling cycles.	(D) 90% 0% to 100%
Heat Fan Speed – Sets the fan speed during moderate heating cycles.	(D) 70% 0% to 100%
Heat Speed - Stage 2 – Sets the fan speed during aggressive heating cycles.	(D) 90% 0% to 100%
Ventilation Fan Speed – Sets the fan speed during ventilation cycles.	(D) 50% 0% to 100%

Power Consumption

Provides settings for the consumption of different demand states.

BTU - British Thermal Units - most common for gas furnaces and hot water.

TON - Tonnage - most common for compressor stages and chilled water.

KW - Kilowatt - most accurate if true kilowatt consumption is known for each stage.

WATT - Watt - most accurate if true watt of consumption is known for each stage.

Configuration Name/Description	Settings/Range
Heat Size – Sets the energy consumption when the moderate heating is enabled.	(D) (blank) (R) Variable input
Heat 2 Size – Sets the energy consumption when the aggressive heating is enabled.	(D) (blank) (R) Variable input
Cool Size – Sets the energy consumption when the moderate cooling is enabled.	(D) (blank) (R) Variable input
Cool 2 Size – Sets the energy consumption when the aggressive cooling is enabled.	(D) (blank) (R) Variable input
Zone Size – Identifies a general size (CFM) for this zone. Used for capacity management sequences.	(D) Medium (R) Small Large Extra-Large

Input Configurations

IMPORTANT

This section goes over the T, T1, T2, & T3 configurations. For analog inputs, S1 & S2, there are advanced configuration that can be used by Pelican Application Engineers and are project specific.

Temperature Configuration Definitions:

Temperature – Identifies the input as an additional room or zone sensor. This sensor will be averaged with the thermostat's temperature sensor.

Temp Monitor – When an input is set to Temp Monitor, this sensor receives its own custom label and its own graphics for viewing real-time and historical temperature readings.

Supply Temperature (most commonly used) – Identifies the temperature reading as the discharge air temperature leaving the terminal box. In modulating applications, this will be used when targeting a reheat discharge temperature.

Return Temperature – Identifies the temperature reading as a return air temperature. Not generally used in damper control applications.

Outside Temperature – Identifies the temperature reading as an outside air temperature. Not generally used in damper control applications.

Alarm – When an input is set for Alarm, it becomes a dry-contact input. Additional configurations become available to define when this alarm is active:

- **Always** - If the dry-contact changes states, a notification will be generated.
- **During: Heating** - If the dry-contact is not in the correct state during a heating cycle, a notification will be generated.
- **During: Cooling** - If the dry-contact is not in the correct state during a cooling cycle, a notification will be generated.
- **During: Fan** - If the dry-contact is not in the correct state during a fan active cycle, a notification will be generated.

Occupancy Sensor– When an input is set for Occupancy sensor, it becomes a dry-contact input to identify if the room is occupied or unoccupied. A third-party occupancy sensor must be wired to the thermostat.

- **Contact Open** - Room is unoccupied and the thermostat sets back the temperature set-points.
- **Contact Closed** - Room is occupied and the thermostat goes to the scheduled temperature set-points.

Input Sensor T1

Only available if a PEARL is wired to the thermostat. When set to ON, this input can be set to any of the following:

Configuration	Settings
Function – Sets what function this input will be used for.	(D) Supply Temperature Temperature Temp Monitor Return Temperature Outside Temperature Alarm Occupancy Sensor

Input Sensor T2

Only available if a PEARL is wired to the thermostat. When set to ON, this input can be set to any of the following:

Configuration	Settings
Function – Sets what function this input will be used for.	(D) Return Temperature Temperature Temp Monitor Supply Temperature Outside Temperature Alarm Occupancy Sensor

Input Sensor T3

Only available if a PEARL is wired to the thermostat. When set to ON, this input can be set to any of the following:

Configuration	Settings
Function – Sets what function this input will be used for.	(D) Outside Temperature Temperature Temp Monitor Supply Temperature Return Temperature Alarm Occupancy Sensor

Wired Sensor

Only available if a TA1 is wired to the thermostat. This input can be set to any of the following:

Configuration	Settings
Function – Sets what function this input will be used for.	(D) Temperature Temp Monitor Supply Temperature Return Temperature Outside Temperature Alarm Occupancy Sensor

Advanced Configurations

Advanced configurations have limited access. For assistance with advanced configurations, please contact Pelican engineering support.

IMPORTANT

This section is for reference only. Thermostats regularly receives updates and additional configuration options that may not be included in this guide. For further assistance or help with specific application needs, contact Pelican engineering support.

Display Settings

Adjust what is displayed on a thermostat's screen.

Configuration Name/Description	Settings/Range
Display Type – Identifies how the thermostat display should look.	(D) Thermostat Default Time Only ¹ Remote Sensors ²
Disable Fan Button – Display or hide the fan button on the thermostat.	(D) No Yes
Disable Mode Button – Display or hide the mode button on the thermostat.	(D) No Yes

¹The thermostat will only display the time on the bottom of the display and the info button in the top right of the screen. All thermostat functions remain active and are controlled through the web-app.

²If there are remote sensors wired to the thermostat, they can be selected to display their readings on the thermostat's display.

Variable Temperature Settings

Provides adjustment to the modulation reheat strategies and which analog output is assigned to the reheat sequence.

Configuration Name/Description	Settings/Range
Type – sets what modulating sources are available to the controller.	(D) None Heat Cool Heat & Cool
Modulating Heat Configurations:	
Heat Signal Output – sets which analog output is used for reheat modulation.	(D) A1 A2
Heat Actuator Voltages – Sets the volt [DC] range for the modulating reheat source: Open = Max Heating Closed = No Heating	Open: (D) 10.0V DC (R) 0.0 to 10.0 Closed: (D) 2.0V DC (R) 0.0 to 10.0
Heat Always Active – the controller will continuously modulate its reheat source to maintain the moderate heating target.	(D) No Yes
Initial Heat Actuator Position – sets the starting volt DC output when a reheat cycle begins.	(D) 30% (R) 0% to 100%
Change Heat Actuator Delay Minutes – sets an interval timer for when the next calculated modulation adjustment is made.	(D) 1 minute (R) 1 to 10 minutes
Moderate Heat Target – Sets the moderate reheat target supply temperature.	(D) 105°F (R) -22°F to 180°F
Aggressive Heat Target – Sets the aggressive reheat target supply temperature.	(D) 115°F (R) -22°F to 180°F
Temper Air During Ventilation – the controller will temper the discharge during ventilation cycles.	(D) Off On
Ventilation Delta Degrees – temper during ventilation this many degrees above the thermostat's heat set point.	(D) 0°F (R) 0°F to 10°F

Sequence of Operations

The zone thermostats and accessories support various types of configurations which affect internal sequences, including:

- Single zone damper control.
- Dual duct zone damper control.
- Mixing box zone damper control.
- Zone reheat operation.
- Two-position, floating type, and modulating control of varies dampers and reheats.
- Terminal fan powered box control.
- Room temperature and reset sequences.
- Schedules which include occupied/unoccupied, events, and vacation adjustability.
- Optimum Start adaptive algorithm.
- Minimum capacity limiting and intelligent dumping sequences.
- and more. . .

For sequences that are outside of this document, contact Pelican support for further assistance.

Thermostat Operations and Scheduling

Thermostat operation is based on schedules and/or manual overrides. Each thermostat can be set with Occupied and Unoccupied schedules, allowing up to 12 set times per day. Each set time represents a specific point when the thermostat will adjust its mode, fan, or other operational settings. Scheduling features include:

- **Occupied/Unoccupied schedules:** Adjust thermostat operation on a 7-day, 5-2, or daily schedule based on normally occupied and unoccupied hours.
- **Event schedules:** Temporarily adjust thermostat operations for specific events.
- **Vacation schedules:** Modify settings during periods when the space is unoccupied for extended durations.

The Pelican Connect app provides a schedule dashboard for managing thermostat schedules. Users can set Occupied/Unoccupied periods, event periods, and/or vacation periods.

Thermostats can also be manually enabled through the app or directly at the thermostats installed inside the building, if allowed.

Zone Operations and Communication

Zone thermostat operations are tied to the heating, cooling, and ventilation demands sent to a central Pelican Zone Coordinator. All zone thermostat that are ducted to a common air handler send their request for a specific action (such as a need to opening a damper for cooling or starting a reheat cycle) to the zone coordinator. In most cases, the thermostat waits for approval from the zone coordinator before taking action.

In some applications you will see “Waiting” identified under the thermostat in the Pelican web-app. This is a normally state and indicates that the thermostat wants a cycle to start, but the air handler controller has a different cycle currently active.

Communication between the thermostat and zone coordinator is two-way, enabling the zone coordinator to send instructions back to the thermostat to force adjustments when necessary.

Communication Link

Thermostats communicate with their zone coordinators via the Pelican wireless mesh network. To establish a connection between the thermostat and the zone coordinator, use the Pelican Connect web-app. Once connected, the following communication sequences occur:

- **Cooling cycle request:** The thermostat requests cooling and provides information on how much cooling the zone requires.
- **Heating cycle request:** The thermostat requests heating, including details on how much heating is needed.
- **Reheat cycle request:** The thermostat requests reheat operations, with the amount of heating specified.
- **Ventilation request:** General fan request for ventilation sequences. The zone also sends its CO2 readings, when available, to initiate demand ventilation sequences.
- **Dehumidification request:** The thermostat requests dehumidification cycles.
- **Zone coordinator updates:** The zone coordinator provides real-time updates on the current active air handler cycles to each zone thermostat.

Sequence of Operations

Optimum Start

To enable Optimum Start, ensure that it is activated in the zone thermostat's schedule settings.

When Optimum Start is enabled, the zone thermostat uses an Adaptive Learning Algorithm to determine when to initiate cooling or heating cycles. This ensures that the zone reaches the desired set points by the scheduled occupied time. Optimum Start can begin as early as 12:01 AM, though it typically starts much closer to the actual occupied time.

Each day, the zone thermostat analyzes the past seven days of heating and cooling trend data for its zone. Using this data, the thermostat calculates how long it takes to pre-condition the space and compares this rate with the current room temperature. This allows the thermostat to calculate the optimal time to start conditioning the space to meet the setpoints by the occupied time.

Because each zone thermostat independently determines its start time, the building's overall cooling or heating efficiency improves, as the air handler is only activated when necessary, aligning closer to the actual demand of the building.

Damper Operations Based on Configured Types and Active Cycles

Thermostat damper positions are determined by the configured damper type and the active cycle managed by the zone coordinator. For more details on how the zone coordinator handles thermostat demands, refer to the zone coordinator's installation manual.

A. Zone Damper without Reheat:

Thermostats with the following configurations:

- **Damper Type:** Open/Closed, Floating, Modulating
- **Reheat Type:** None

will operate as follows:

Cooling Demand: The following conditions must be met for a cooling cycle to begin:

- **Reliable Communication:** The thermostat must be able to communicate with the zone coordinator.
- **Available Cycle:** The zone coordinator must be able to initiate a cooling cycle by placing the HVAC equipment in cooling mode (refer to the zone coordinator installation manual for specifics).
- **Capacity Management:** The minimum number of zones must be in cooling demand or able to provide airflow, if being used.

- **No Active Heating Cycle:** The zone coordinator must not be in an active heating cycle.

Thermostats with cooling demand will send a cool request to the zone coordinator, specifying how much cooling is needed. Once the zone coordinator calculates that cooling can start, it communicates the "cooling to start" signal to all thermostats. Thermostats with cooling demand will rotate their dampers to 100% open or to their configured Maximum Damper Positions, whichever is lower. Those without cooling demand will close their dampers. The cooling cycle begins after thermostat acknowledge the cycle change.

The cooling cycle remains active until all cooling demands are satisfied, one of the cooling preconditions is no longer met, or a change-over cycle occurs.

Heating Demand: The following conditions must be met for a central heating cycle to begin:

- **Reliable Communication:** The thermostat must be able to communicate with the zone coordinator.
- **Available Cycle:** The zone coordinator must be able to initiate a central heating cycle by placing the HVAC equipment in heating mode (refer to the zone coordinator installation manual for specifics).
- **Capacity Management:** The minimum number of zones must be in heating demand or able to provide airflow, if being used.
- **No Active Cooling Cycle:** The zone coordinator must not be in an active cooling cycle.

Thermostats with heating demand will rotate their dampers to 100% open or to their Maximum Damper Positions, whichever is lower. Those without heating demand will close their dampers. The central heating cycle begins after thermostat acknowledge the cycle change.

The heating cycle remains active until all heating demands are met, one of the heating preconditions is no longer satisfied, or a change-over cycle occurs.

Ventilation/Fan Only Demand: The following conditions must be met for a ventilation/fan-only cycle:

- **Reliable Communication:** The thermostat must be able to communicate with the zone coordinator.
- **Available Cycle:** The zone coordinator must be able to initiate a ventilation cycle by placing the HVAC equipment in fan only mode (refer to the zone coordinator installation manual for specifics).

Sequence of Operations

- **Capacity Management:** The minimum number of zones must be in ventilation demand or able to provide airflow, if being used.
- **No Active Heating or Cooling Cycle:** The zone coordinator must not be in an active heating or cooling cycle.

Thermostats with Fan demand will open their dampers to 100% or their Ventilation Damper Positions; whichever is less. Those without ventilation demand will close their dampers. The ventilation/fan-only cycle remains active until the preconditions are no longer satisfied.

B. Zone Damper with Reheat:

Thermostats with the following configurations:

- **Damper Type:** Open/Closed, Floating, Modulating
- **Reheat Type:** Open/Close, Electric, Floating, Modulating

will operate in a similar way to non-reheat zones, with the addition of reheat control during heating and ventilation cycles.

Heating with Reheat: When the following conditions are met, a reheat cycle will begin:

- **Reliable Communication:** The thermostat must be able to communicate with the zone coordinator.
- **No Active Cooling Cycle:** The zone coordinator must not be in an active cooling cycle.

Thermostats with heating demand will rotate their dampers to 100% open or to their Maximum Damper Positions, whichever is lower. Those without heating demand will place their dampers in their Ventilation Damper positions.

For zones with hot water reheat valves: The thermostat will acknowledge the cycle change, and enable or modulate their hot water valves to reheat the air delivered into the zone.

For zones with electric reheat coils: The thermostat will acknowledge the cycle change, wait until proof of fan is provided from the zone coordinator, and then enable and/or modulate their electric coils to reheat the air delivered into the zone.

For modulating reheats: The thermostat will adjust the voltage to the modulating reheat to target a discharge air temperature based on if the zone thermostat is in moderate or aggressive heating demand.

The reheating cycle remains active until all heating

demands are met, one of the heating with reheat preconditions are no longer satisfied, or a change-over cycle occurs.

Heating with Central Heat (Morning Warm-Up): When the total heating demand is sufficient, the zone coordinator may initiate a central heating cycle.

The following conditions must be met for a central heating cycle to begin:

- **Reliable Communication:** The thermostat must be able to communicate with the zone coordinator.
- **Available Cycle:** The zone coordinator must be able to initiate a central heating cycle by placing the HVAC equipment in heating mode (refer to the zone coordinator installation manual for specifics).
- **Capacity Management:** The minimum number of zones must be in heating demand or able to provide airflow, if being used.
- **No Active Cooling Cycle:** The zone coordinator must not be in an active cooling cycle.

Thermostats with heating demand will rotate their dampers to 100% open or to their Maximum Damper Positions, whichever is lower. Those without heating demand will close their dampers. The central heating cycle begins after thermostat acknowledge the cycle change.

The heating cycle remains active until all heating demands are met, one of the heating preconditions is no longer satisfied, or a change-over cycle occurs.

Ventilation/Fan Only Demand: Ventilation cycles occur anytime there is no central heating or central cooling cycles active. Zones with reheats, which have heating demand, are allowed to utilize their reheats during ventilation cycles.

C. Zone Damper with a Series Fan:

Thermostats configured with the following settings:

- **Damper Type:** Open/Closed, Floating, or Modulating
- **Reheat Type:** Fan Powered
- **Fan Control:** Series

will operate in a similar way to reheat zones, with the addition of fan control during cooling, reheating, central heating and ventilation cycles.

During a cooling cycle, the series fan is enabled to pull air from the primary duct.

Sequence of Operations

During a reheat cycle, the zone damper remains closed, and the series fan is enabled to pull air from the induced airstream (plenum) into the box.

The zone is allowed to start a "Heating with Reheat" cycle without the requirement that there is no active cooling cycle since the airflow comes from the induced airstream instead of the primary duct.

D. Zone Damper with a Parallel Fan:

Thermostats configured with the following settings:

- **Damper Type:** Open/Closed, Floating, or Modulating
- **Reheat Type:** Fan Powered
- **Fan Control:** Parallel

will operate similarly to Series Fan systems with a few key differences:

During cooling cycles, the parallel fan remains disabled.

During a reheat cycle, the zone damper remains closed, and the parallel fan pulls air from the induced airstream (plenum) into the box.

The zone is allowed to start a "Heating with Reheat" cycle without the requirement that there is no active cooling cycle since the airflow comes from the induced airstream instead of the primary duct.

E. Zone Mixing Box Dampers:

Thermostats configured with the following settings:

- **Damper Type:** Mixing Box, Modulating Mixing Box
- **Reheat Type:** None

will operate as follows:

Cooling Demand: The following conditions must be met for a cooling cycle to begin:

- **Reliable Communication:** The thermostat must be able to communicate with the zone coordinator.
- **Available Cycle:** The zone coordinator must be able to initiate a cooling cycle by placing the HVAC equipment in cooling mode (refer to the zone coordinator installation manual for specifics).
- **Capacity Management:** The minimum number of zones must be in cooling demand or able to provide airflow, if being used.

- **No Active Heating Cycle:** The zone coordinator must not be in an active heating cycle.

Initially, the zone thermostat sends a cooling request to the zone coordinator, indicating the required cooling. When the zone coordinator determines that cooling can start, it communicates with all thermostats to initiate the cycle.

Thermostats with cooling demand will open their cold ducts, which in affect closes their hot duct (because they are mechanically linked). Thermostats without cooling demand will close their cold duct and open the hot duct to receive re-circulation/ventilation air.

The cooling cycle remains active until all cooling demands are met or a change-over cycle occurs.

Heating Demand: The following conditions must be met for a heating cycle to begin:

- **Reliable Communication:** The thermostat must be able to communicate with the zone coordinator.
- **Available Cycle:** The zone coordinator must be able to initiate a heating cycle by placing the HVAC equipment in heating mode (refer to the zone coordinator installation manual for specifics).
- **Capacity Management:** The minimum number of zones must be in heating demand or able to provide airflow, if being used.
- **No Active Cooling Cycle:** The zone coordinator must not be in an active cooling cycle.

Initially, the zone thermostat sends a heating request to the zone coordinator, indicating the required heating. When the zone coordinator determines that heating can start, it communicates with all thermostats to initiate the cycle.

Thermostats with heating demand will open their hot ducts, which in affect closes their cold duct (because they are mechanically linked). Thermostats without heating demand will close their hot duct and open the cold duct to receive re-circulation/ventilation air.

The heating cycle remains active until all heating demands are met or a change-over cycle occurs.

Ventilation/Fan Only Demand: The following conditions must be met for a ventilation/fan-only cycle:

- **Reliable Communication:** The thermostat must be able to communicate with the zone coordinator.

Sequence of Operations

In Mixing Box applications, if all thermostat demands are for Ventilation/Fan, all thermostats open their cold duct and in affect close their hot duct (because they are mechanically linked).

If there is an active cooling or heating cycle, thermostats without cooling or heating demand receive ventilation/re-circulation air through the un-conditioned duct. For example, if the cold duct is currently delivering cold conditioned air, then zones which do not need cold air will have their cold duct closed and their hot duct open to receive re-circulation/ventilation air from the hot duct.

F. Zone Dual Duct Dampers:

Thermostats configured with the following settings:

- **System Type:** Dual Duct Damper
- **Cool Damper Type:** Open/Closed, Floating, or Modulating
- **Heat Damper Type:** Open/Closed, Floating, or Modulating
- **Reheat Type:** None

will operate as follows:

Cooling Demand: The following conditions must be met for a cooling cycle to begin:

- **Reliable Communication:** The thermostat must be able to communicate with the cold deck zone coordinator.
- **Available Cycle:** The zone coordinator must be able to initiate a cooling cycle by placing the HVAC equipment in cooling mode (refer to the zone coordinator installation manual for specifics).
- **Capacity Management:** The minimum number of zones must be in cooling demand or able to provide airflow, if being used.

Thermostats with cooling demand will send a cool request to the cold deck zone coordinator, specifying how much cooling is needed. Once the zone coordinator calculates that cooling can start, it communicates the "cooling to start" signal to all thermostats. Thermostats with cooling demand will rotate their cold duct dampers to 100% open or to their configured Maximum Damper Positions, whichever is lower. Those without cooling demand will close their cold duct dampers and, if available, open their hot duct dampers to receive ventilation/transfer air. The cooling cycle begins after thermostat acknowledge the cycle change.

The cooling cycle remains active until all cooling demands are satisfied or one of the cooling

preconditions are no longer met.

Heating Demand: The following conditions must be met for a central heating cycle to begin:

- **Reliable Communication:** The thermostat must be able to communicate with the hot deck zone coordinator.
- **Available Cycle:** The zone coordinator must be able to initiate a central heating cycle by placing the HVAC equipment in heating mode (refer to the zone coordinator installation manual for specifics).
- **Capacity Management:** The minimum number of zones must be in heating demand or able to provide airflow, if being used.

Thermostats with heating demand will rotate their hot duct dampers to 100% open or to their Maximum Damper Positions, whichever is lower. Those without heating demand will close their hot duct dampers and, if available, open their cold duct dampers to receive ventilation air. The central heating cycle begins after thermostat acknowledge the cycle change.

The heating cycle remains active until all heating demands are met or one of the heating preconditions is no longer satisfied.

Ventilation/Fan Only Demand: The following conditions must be met for a ventilation/fan-only cycle:

- **Reliable Communication:** The thermostat must be able to communicate with the cold deck and hot deck zone coordinators.
- **Available Cycle:** One of the zone coordinators must be able to initiate a ventilation cycle by placing its HVAC equipment into fan only mode (refer to the zone coordinator installation manual for specifics).
- **Capacity Management:** The minimum number of zones must be in ventilation demand or able to provide airflow, if being used.
- **Both Heating and Cooling Cycle are Not Active:** Both zone coordinators must not be in an active heating or cooling cycle.

Thermostats with Fan demand will open the damper to the duct that can provide ventilation/transfer air. They will rotate that damper 100% open or to their Ventilation Damper Positions. Those without ventilation demand will close both dampers. The primary ventilation duct is the cold deck. The ventilation/fan-only cycle remains active until the preconditions are no longer satisfied.

Sequence of Operations

Demand Ventilation

To increase energy efficiency in relation to ventilation needs based on actual occupancy, Pelican zone thermostats with in-room CO₂ sensors can be used for demand ventilation sequences.

The following conditions must be true for a demand ventilation cycle to start:

- **Reliable Communication:** The thermostat must be able to communicate with the zone coordinator.
- **Available Cycle:** The zone coordinator must have control over the outside damper on the HVAC equipment (refer to the zone coordinator installation manual for details).
- **Ventilation Allowance:** Demand ventilation must be enabled in the thermostat's configurations, and the thermostat should not be sending a "do not ventilate" message. This feature is generally applied during unoccupied hours or emergency situations (e.g., Shelter-in-Place) when ventilation is not required.
- **CO₂ Reading:** The zone thermostat must have a CO₂ sensor with a reading above the configured CO₂ threshold for ventilation.

When these preconditions are met, the zone thermostat sends a Demand Ventilation request to the zone coordinator, including the current CO₂ level in the zone.

The zone coordinator then initiates its Demand Ventilation sequence to determine how much additional outside air needs to be mixed into the supply air stream (refer to the zone coordinator installation manual for specific calculations and configurations).

If the CO₂ levels fall below the configured threshold and all other ventilation preconditions are still met, the zone coordinator will adjust ventilation to maintain the Minimum Damper Position setting.

Pre-Occupancy Ventilation

The pre-occupancy ventilation cycle enables zone thermostats to request outside air to purge indoor contaminants before the building becomes occupied. This cycle follows the same sequence as the standard Ventilation/Fan Only cycles detailed in previous zone damper sequences.

To ensure effective pre-occupancy ventilation, zone thermostats should be scheduled to initiate a Ventilation/Fan Only cycle at least 1–2 hours before the regular occupancy period begins.

Fan Purge Cycle

The Fan Purge Cycle keeps zone thermostat dampers open after a heating or cooling cycle to release any residual energy from the air handler or reheat system into the room. This process enhances the overall energy efficiency of the mechanical system.

Dehumidification

Zone thermostats equipped with in-room Relative Humidity (RH) sensors can be configured to request dehumidification cycles from their zone coordinator.

When a humidity sensor is used to control dehumidification, each thermostat has a humidity set point. If the thermostat detects that the room humidity exceeds this set point, it sends a Dehumidification Request to the zone coordinator.

In response, the zone coordinator enters dehumidification mode, which may involve:

- Activating compressors to lower the humidity in the supply air.
- Modulating a reheat source to temper the supply air as it returns to the zones.
- Enabling a hot gas bypass or other dehumidification methods.

The dehumidification cycle continues until all thermostats' relative humidity readings fall to or below their set points, there is no longer an active demand for dehumidification, or a different cycle that overrides dehumidification begins.

Refer to the zone coordinator installation manual for specific calculations and configurations.

Waiting...

"Waiting" is a normal status for a Pelican zone thermostat. Thermostats enter the Waiting status when a cycle they do not currently need is active, or Capacity Management is in effect. The Waiting status can indicate:

- The zone has demand for a different cycle and is waiting for the zone coordinator to switch to that cycle.
- The zone has demand and is awaiting confirmation from the zone coordinator that its requested cycle can begin.
- In rare cases, a zone may remain in Waiting due to communication issues, such as being unable to send or receive messages with the zone coordinator.

Sequence of Operations

Capacity Management

When Capacity Management is enabled in a zoned cycle, some zones may enter a "Waiting" state until sufficient capacity is available for their requested cycle to begin.

For effective Capacity Management, each Pelican zone thermostat should be configured with a zone size. This setting indicates the amount of airflow (CFM) available from the space during a cooling or heating cycle.

Size Options:

- x-small (< 200 sq. ft.)
- small (200 - 500 sq. ft.)
- medium (500 - 1000 sq. ft.) (default)
- large (1000 - 2000 sq. ft.)
- x-large (> 2000 sq. ft.)

When zone sizes are configured, the zone coordinator receives cycle requests and assesses which zones can accept additional airflow to enable the requested cycle.

This strategy helps prevent mechanical cooling or central heating from starting when there is insufficient airflow, even if only a few zones require conditioning. Note: This algorithm should be used as a last-resort option as it may cause discomfort in some zones during low cooling or heating demands.

Additional Capacity Management logic can be implemented, including but not limited to:

- Limited Zone Dump PID loops,
- Full Dump configurations,
- Allow Zero Heat Stages,
- Adjustments to Minimum and Maximum Supply Temperature allowances,
- Various target supply temperature resets and staging strategies.

Refer to the zone coordinator installation manual for detailed calculations and configurations.

Occupied Fan Demand

During occupied hours, all thermostats should be set to call for Fan. This ensures that ventilation, recirculation, and balancing sequences can run between heating and cooling cycles.

Appendix A: Signal Outputs

The Pelican Connect app provides access to a zone thermostat's signal outputs and analog input/output through a manual override page. This page is primarily designed for information purposes but can also be used to troubleshoot signals through manual changes.

IMPORTANT

The Signal Output page is a MASTER OVERRIDE feature of the zone thermostat's 24 VAC signals. The zone thermostat DOES NOT know when these 24 VAC signals are being manually changed. It is extremely important that these 24 VAC outputs are only changed during equipment testing and not used if not well understood. If one or more 24 VAC signals are manually changed, they must be changed back to the correct state.

As for the analog outputs (0-10 VDC), the zone thermostat will not allow you to manually change them if they are link to a control sequence. To manually adjust these outputs, the configuration linked to that analog output needs to be disabled.

IF THESE WARNINGS ARE CONFUSING, STOP WHAT YOU ARE DOING AND CONTACT PELICAN TECHNICAL SUPPORT FOR FURTHER ASSISTANCE.

Relay Outputs:

Each 24 VAC Relay Output shows the current output state from that terminal of the zone thermostat .

- **Gray** means the output is disabled.
- **Green** means the output is enabled.

If the output button is pressed, a signal will be sent to the zone thermostat to change the selected output's state. The Pelican Connect app will update the output when the app receives confirmation from the zone thermostat that it has received and changed the signal.

Analog Signals:

Each Analog Output shows the current voltage (V DC) output from that terminal. Analog output sliders will only allow for manual control if the modulation logic linked to that output is disabled. If modulation logic is enabled, the slider might move temporarily, but the zone thermostat will reset the change within a few minutes.

Each Analog Input shows the current DV voltage being inputted into that terminal up to a max reading of 10V DC.

Appendix B: Max Damper Positions

The Max Damper Position configuration is available for floating or modulating damper actuator control sequences.

In most applications, the max damper position should be set to 100% open. However, in cases where zones receive more air than necessary, the max damper position can be adjusted lower to reduce the airflow (CFM) into that zone.

Steps for Adjusting Max Damper Position:

- **Verify Operating Static Pressure:** Ensure the correct static pressure targets are configured at the zone coordinator before adjusting max damper positions.
- **Initial Setup:** Set all zone dampers to rotate fully open (100%) to establish the static pressure target, ensuring the farthest zone receives its maximum airflow rate (max CFM).
- **Balance Adjustments:** Once the operating static pressure is established, adjust other zone dampers' max positions to achieve balanced airflow across all zones.

If CFM is not used for balancing, system performance (cooling and heating) can be utilized to balance cycles. When static pressure is correctly set but some zones continue to heat or cool too rapidly, reducing the max damper position in those specific zones can help stabilize the heating or cooling rate.

Note: Performance balancing does not address potential noise issues. If a zone has been balanced for performance and the airflow noise is louder than desired, further adjustment to the max damper position may be applied. However, avoid setting the max damper position lower than the required airflow rate needed to meet heating and cooling loads.

For additional assistance with balancing, please contact Pelican Technical Support.

Appendix C: Min Ventilation Positions

The Min Ventilation Position configuration is available for floating or modulating damper actuator control sequences.

In most applications, the min ventilation damper position should be set to 100% open. However, if a zone receives more air than necessary, the min ventilation position can be adjusted lower to reduce the airflow (CFM) into that zone.

Steps for Adjusting Ventilation Damper Position:

- **Verify Circulation Static Pressure:** Ensure that the correct circulation static pressure targets are set at the zone coordinator before adjusting min ventilation damper positions.
- **Initial Setup:** Set all zone dampers to rotate fully open (100%) to establish the static pressure target, ensuring the farthest zone receives more than its minimum ventilation airflow rate.
- **Balance Adjustments:** Once the circulation static pressure is set, adjust other zone dampers' min damper positions to achieve balanced airflow across all zones.

Note: The Min Ventilation Position differs from traditional VAV minimum damper positions. This damper setting is used when there is no active heating or cooling cycle and should be set much higher than the minimum damper position found in traditional VAV systems. In the Pelican system, the min ventilation position should promote a high zone air change-over rate to maximize recirculation and reduce stagnant air.

For further assistance with balancing, please contact Pelican Technical Support.

