

Model: Z8

Zone Coordinator



What is the zone coordinator?

The zone coordinator is a field-installed equipment controller. For most applications, it controls the central equipment that provides heating, cooling, and ventilation to multiple zones or spaces.

This installation manual explains how to use a zone coordinator as a multi-zone HVAC equipment controller. This controller can also operate a variety of other centralized equipment such as, but not limited to, exhaust fans, make-up air units, boilers, cooling towers, chillers, etc. For applications outside the scope of this installation manual, please contact Pelican engineering or technical support for further guidance.

How the Pelican zoning solution works

The zone coordinator is one device in Pelican's zoning solution. It is installed as the central air handler controller, while Pelican thermostats are installed to control individual zone dampers and/or reheat positions. The zone coordinator establishes communication with each of its zone thermostats over Pelican's wireless mesh network. Thermostats send real-time heating, cooling, and ventilation requests to the zone coordinator, which processes these requests and makes adjustments to the central equipment to satisfy the different zone demands. The Pelican zoning solution's logic is designed to enhance equipment

Installation Manual

performance, energy efficiency, and building comfort across the entire mechanical system.

The wireless mesh network also provides an Internet connection for these devices to reach the Pelican Connect app (for more information visit PelicanWireless.com or contact Pelican support). Zone coordinators and their associated thermostats are configured through this web application.

Configurations provide adjustments on how the zone coordinator will control the central equipment and which sequences and targets are active. For more information on standard zone coordinator sequences, reference "Sequence of Operations" on page 37.

The Pelican zoning solution and its related devices require an Internet connection¹ for initial device configurations. After configurations are set, the Internet connection provides virtual climate management, data logging, equipment fault notifications, configuration adjustments, and other energy management features. These features are important to verify the correct operation of the zoning solution and should be planned as a retained resource at the end of the installation. If the Internet is down or lost for a period of time, all device configurations are stored locally in each Pelican controller, so all the equipment and communications will continue to operate while the Internet connection is unavailable.

IMPORTANT

The zone coordinator **must** be installed and wired to control the central HVAC equipment for a Pelican zoning solution to work. The zone coordinator provides digital and analog outputs to adjust and modulate how the central equipment is operating. These outputs are further detailed in later sections of this installation manual. The zone coordinator also allows zone thermostats to function as zone damper controllers. This is detailed in the Pelican Damper Controller installation manual.

If the following items cannot be wired and controlled by the zone coordinator, **stop the installation immediately** and contact Pelican engineering support for further assistance:

- 1) The zone coordinator **must** control when the equipment's supply/return fan(s) are active. These fans must be able to run

¹A Pelican Gateway is required for Internet connection.

even without mechanical cooling or central heating active.

- 2) The zone coordinator **must** be able to read and control the supply duct static pressure either through controlling a modulating fan, a modulating bypass damper, or some other feature, such as inlet vanes, which allows for adjusting, maintaining, and/or resetting the supply duct static pressure to the zones.
- 3) The zone coordinator **must** be able to directly read supply, return, and outside air temperatures at the equipment.
- 4) The zone coordinator **must** be able to control when mechanical cooling and/or central heating is active and when it is not.

Although not required, the following features **should** be controlled by the zone coordinator:

- 1) The zone coordinator **should** be able to reset how many mechanical cooling and central heating stages the HVAC equipment has active. This can be either through staging, modulating, or providing some type of reset function to the equipment.
- 2) The zone coordinator **should** be controlling the outside damper position. This confirms proper economizer sequences are utilized, allows the solution to maintain proper ventilation rates during all the different possible cycles, and is required for California T24 applications since it provides FD&D capabilities.

Before You Start

Review all instructions in this installation manual before starting to install the zone coordinator to avoid discovering or creating any issues during installation. This controller is designed to be installed on Class 2 - 24V AC systems only.

This controller is designed to be installed by a licensed professional.

A Pelican Gateway must be installed and have a fully established Ethernet connection to set up and use the Pelican zone coordinator. The zone coordinator cannot be configured, commissioned, or managed without a gateway. We recommend installing the gateway prior to installing this product.

Included Parts

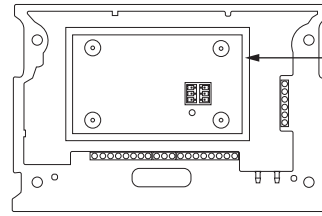

(1) The Zone Coordinator Sub-Base

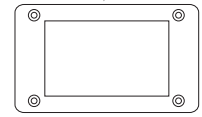

(1) The Antenna
(comes mounted inside sub-base)

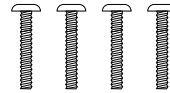

(4) 3/16" Machine Screws
(for mounted antenna on a plastic single gang electric box)

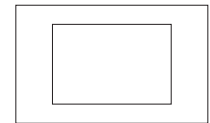

(1) Gasket
(for mounted antenna on a plastic single gang electric box)



(2) 3/16" Sheet Metal Screws
(for mounted zone coordinator sub-base)

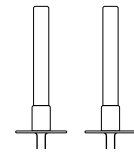

(2) Duct Temp Sensors
(10K Type 2 Thermistors)



(2) Dry-Wall Anchors
(for sheet metal screws)



(1) Vinyl Outdoor Sensor
(10K Type 2 Thermistors)

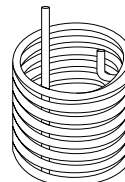

20' of 1/8" plastic hose
(for static probe connection)

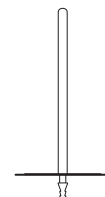

(1) Static Pressure Probe
(3/16" metal barb connector)



3/16" Adapter Tube
(for static probe connection)



3/16" to 1/8" Barb Hose Adapter
(for static probe connection)



(2) 3/16" Sheet Metal Screws
(for mounting static pressure probe)

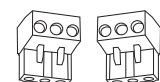

(2) 3-Pin Terminal Blocks
(for antenna wire connections)

Specifications

- **Power:** 24V AC, 60 Hz, 200 mA
- **Operating Voltages:** 23 — 30V AC
- **Number of Binary Outputs:** Eight (8)
- **Binary Output Relay Ratings:** 24V AC @ 2.0 A
- **Number of Analog Outputs:** Four (4)
- **Analog Output Range:** 0 [2] — 10V DC
- **Number of Analog Inputs:** Two (2)
- **Analog Input Range:** 0 [2] — 10V DC
- **Communication Outputs:** DirectLink [RS-485]
- **Differential Pressure Range:** 0.0 to 8.0 inch of water column
- **Number of Thermistor Inputs:** Three (3)
- **Thermistor Type:** 10K Type II (77°F @ 10000 Ohms)
- **Temperature Detection Range:** -20°F — 180°F
- **Code Compliant:** Meets California T24 Code. Follows ASHREA Economizer and Ventilation Standards.
- **Number of Zones:** Maximum of Eight (8) Pelican zone thermostat demands can be coordinated by this controller.
- **Number of Heat Stages:** Max of Three (3) Stages.
- **Number of Cool Stages:** Max of Three (3) Stages.
- **Wireless:** 2.4 GHz wireless frequency, IEEE 802.15.4 wireless standard. Complies with Class B Part 15 of FCC rules. Does not interfere or communicate with WiFi/802.11 networks. Pelican Mesh Network Enabled.
- **Operating Range:** -4°F — 160°F @ 5 % — 90 % Relative Humidity (non-condensing)
- **Storage Temperature:** -20°F — 160°F

California Title 24

This device meets California's Title 24 energy efficiency standards.

Safety Considerations

Disconnect electrical power to the power source and/or the HVAC equipment before wiring the Pelican zone coordinator. Failure to follow this warning could cause electrical shock, personal injury, or damage to the controller.

Dimensions

Zone Coordinator Sub-Base

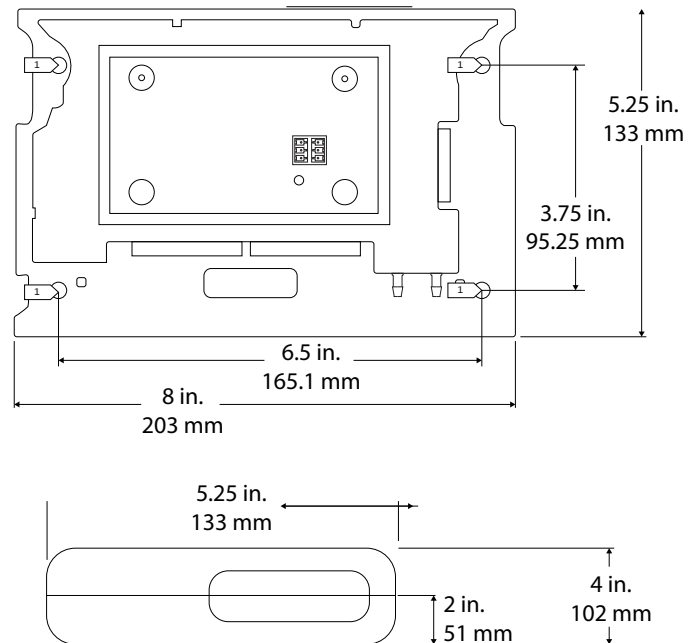

Antenna

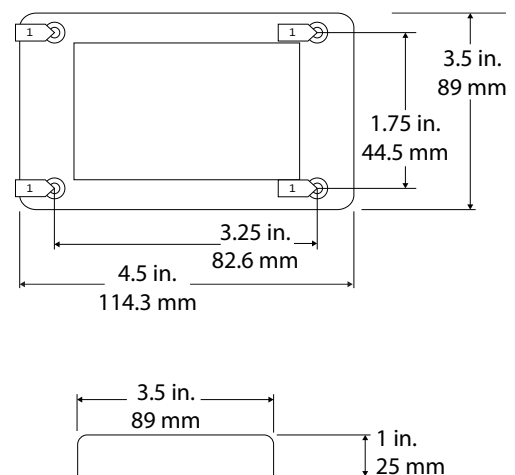

 Mounting holes provide 3/16" diameter opening.

Table of Contents

INTRO	1
What is the zone coordinator? & How does the zoning solution work?	1
Before you start & Included parts	2
Specifications & Dimensions	3
INSTALLATION PLANNING	6
Installing the Pelican Zone Coordinator & Planning Overview	6
Planning - Different Mechanical Systems	6
Variable Temperature and Air Volume (VVT)	7
Variable Air Volume (VAV)	8
Mixing Box / Multi-Zone (MB-CAV and MB-VAV)	9
Dual Duct (DD-VAV)	10
Planning - Wireless Networking	11
Mounting	12
Zone Coordinator Sub-Base	12
Antenna	13
Wiring	15
Power	15
Control Diagrams	16
Conventional Cooling and Heating	16
1 to 3 stages	16
Modulating Compressor	17
Modulating Gas Furnace or Electric Heat	17
Heat Pump Cooling and Heating	18
1 to 3 stages	18
Modulating Compressor	19
Chilled Water Valve	19
Floating or Two-Position	19
0[2]—10V DC Modulating	19
Hot Water Valve	20
Floating or Two-Position	20
0[2]—10V DC Modulating	20
Dedicated Hot Water Boiler and Pump	21
Outside Air Damper Control	21
Variable Speed Fan & Outside Air Damper Control	22

Bypass Damper & Outside Air Damper Control	23
Notes	24
Differential Pressure Sensor	26
Temperature Sensors	27
Start-Up	28
Before Start-up	28
Sub-Base LED Lights	29
Antenna LED Light	30
Setting Configurations	31
General Configurations	31
Input Configurations	34
Advanced Configurations	35
Sequence of Operations	37
Appendix	47
A: Retrofitting Install Process	47
B: Signal Outputs	48
C: DirectLink	49

Installing the Pelican Zone Coordinator

We recommend following these steps when planning and installing a zone coordinator:

- 1) Plan your installation needs based on the equipment and mechanical design of the HVAC system; "Planning - Different Mechanical Systems" on page 6.
- 2) Plan mounting locations so the controller will be able to communicate with the Pelican wireless network; "Planning - Wireless Netowrking on pages 11 & 12.
- 3) Mount the sub-base; "Mounting and Wiring - Zone Coordinator Sub-Base on page 12.
- 4) Mount and wire the sub-base to the antenna if the antenna is located in a different location than the sub-base; "Mounting and Wiring - Antenna" on pages 13 & 14.
- 5) Wire the controller to power; "Wiring - Power" on page 15.
- 6) Wire the sub-base to control the HVAC equipment; "Wiring - Control Diagrams" on pages 16 to 21.
- 7) Wire to the outside and economizer damper actuators; "Wiring - Control Diagrams" on pages 22 & 23.
- 8) Install and connect the supply duct static pressure probe; "Install - Differential Pressure Sensor" on page 26.
- 9) Install all temperature probes and wire to controller sub-base; "Wiring - Temperature Sensors" on page 27.
- 10) Start-up, confirm power, and all communication are active; "Start-Up" on page 28 to 30.
- 11) Configure the controller; "Configurations" on pages 31 to 36.

Planning - Different Mechanical Systems

There are six common HVAC mechanical designs that the Pelican zoning solution is commonly used to retrofit and control.

Pages 6 to 10 provide definitions, diagrams, and requirements to implement each of these six different mechanical systems. If you are working on an application that is outside the scope of this installation manual, stop your installation and reach out to Pelican support for further assistance.

Planning - Wireless Networking

It is critical that wireless network planning occurs before installing the zone coordinator. Pages 11 & 12 provide different scenarios, diagrams, and what is required to properly network the controller. If you are working on an application that is outside the scope of this installation manual, stop your installation and reach out to Pelican engineering support for further assistance.

There are two devices included with the zone coordinator: the sub-base, which has all the input and output terminals, and the antenna, which is connected to the sub-base and is used for wireless communication. These devices come as one unit but can be separated and mounted in different locations, then wired back to each other. This design simplifies the installation and networking of the zone coordinator.

The decision on where and how best to mount each component depends on where the HVAC equipment is located, where the Pelican wireless network will be reachable, and how much existing or new wire is available or will need to be added to connect the zone coordinator to the equipment it will be controlling.

The antenna is designed to either remain inside the zone coordinator or communicate with the zone coordinator across a 3-wire power and communication link. Once power is applied, the antenna automatically discovers and builds a 2-way communication link to the Pelican wireless network, Pelican thermostats, and the Pelican gateway.

The antenna stores all its configurations, routes, and logic inside its integrated memory. It collects zone thermostat demands and uses its internal logic algorithms to adjust the sub-base's output to affect the HVAC equipment operation. Equipment adjustments are tracked and pushed to Pelican thermostats and back to the Pelican Connect app for sequencing, data logging, and historical tracking.

A few other items to plan for networking and wireless communication:

- 1) Install the Pelican Gateway in a central location inside the building where it can communicate with a high percentage of Pelican devices and where it can retain a stable connection to the Internet.
- 2) Recognize that the Pelican thermostats are normally the primary wireless repeaters bridging the wireless network around the facility. In some applications, plan to install thermostats early on to help bridge the wireless. For more information on transitioning a building over to Pelican, read the transition installation process on page 47.
- 3) Pelican offers wireless repeaters, which can be used to help extend the wireless network around a facility. Contact the Pelican support team for further assistance with repeater use.

Planning - Different Mechanical Systems - Variable Temperature and Air Volume (VVT)

Variable Temperature and Air Volume (VVT)

A variable temperature and air volume (VVT) system typically consists of a single air handler that provides heating, cooling, and ventilation to multiple zones. To maintain supply duct static pressure, a bypass damper is usually installed between the supply and return ducts and is modulated accordingly. Each zone has a local damper controlled by a Pelican thermostat, which opens and closes to regulate airflow into the respective space.

Requirements for Central Equipment Control

One zone coordinator will be required. The zone coordinator will need to be wired to provide:

- Supply Fan Enable/Disable Control
- Bypass Damper Modulation Control
- Outside, Return, Exhaust Damper Modulation Control
- Cooling Enable/Disable and/or Modulation Control
- Heating Enable/Disable and/or Modulation Control
- Supply Duct Temperature Sensor
- Return Duct Temperature Sensor
- Outside Air Temperature Sensor
- Supply Duct Static Pressure Probe
- Ambient Pressure

For more details on wiring the zone coordinator to each control point, follow the wiring diagrams starting on page 16 of this installation manual.

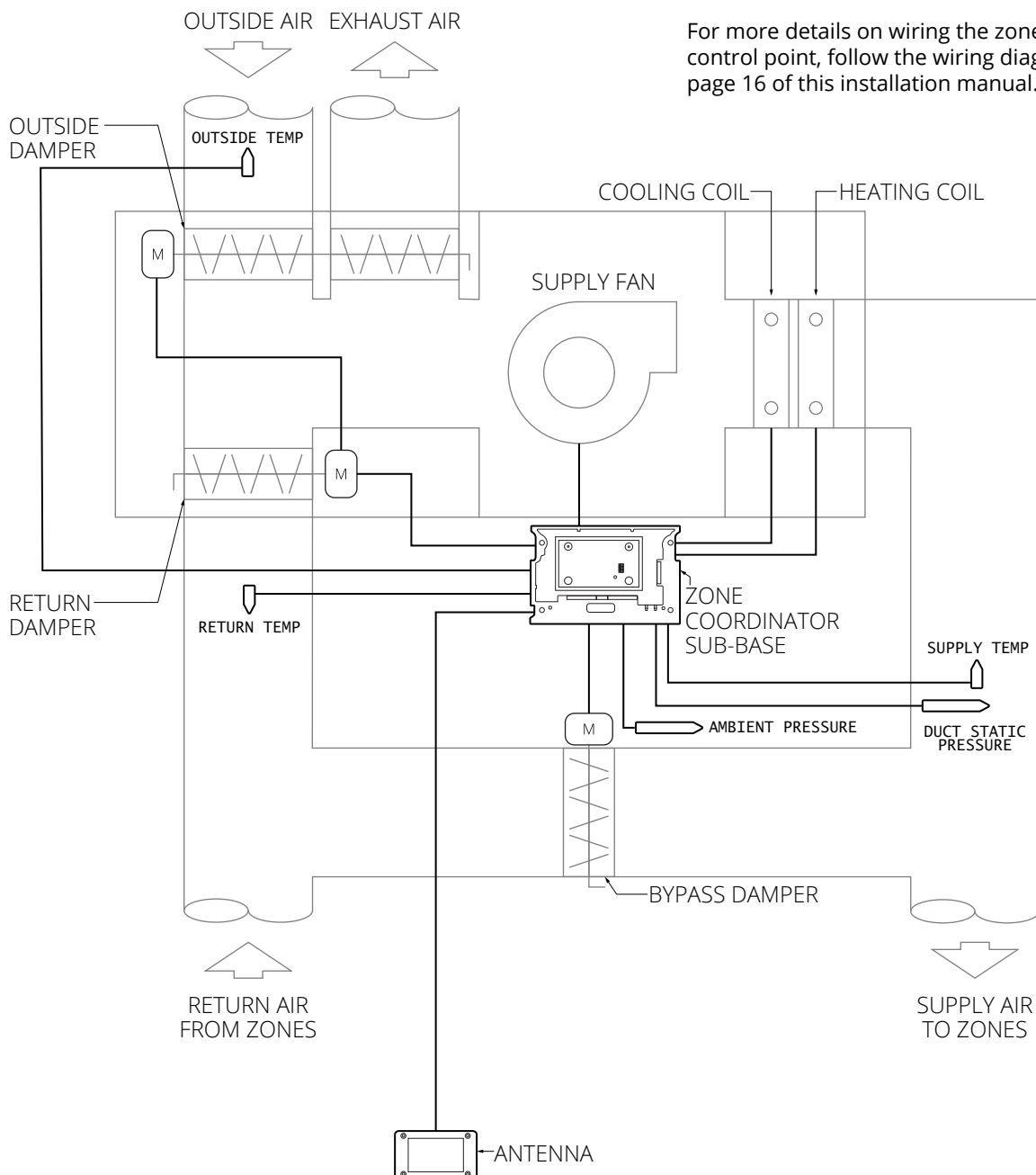

Planning - Different Mechanical Systems - Variable Air Volume (VAV)

Variable Air Volume (VAV)

A variable air volume (VAV) system typically consists of a single air handler that provides cooling and ventilation to multiple zones. Sometimes the air handler includes central heating for morning warm-up or other heating cycles. There is commonly a variable speed supply fan, which is modulated to maintain supply duct static pressure. Each zone has a local damper controlled by a Pelican thermostat, which opens and closes to regulate airflow into its space. Some zones may also have a reheat coil that can be enabled or modulated to heat the air entering the space. Additionally, zone boxes may include a series or parallel fan-powered box.

Requirements for Central Equipment Control

One zone coordinator will be required. The zone coordinator will need to be wired to provide:

- Supply Fan Enable/Disable Control
- Supply Fan Variable Speed Modulation Control
- Outside, Return, Exhaust Damper Modulation Control
- Cooling Enable/Disable and/or Modulation Control
- Heating Enable/Disable and/or Modulation Control
- Supply Duct Temperature Sensor
- Return Duct Temperature Sensor
- Outside Air Temperature Sensor
- Supply Duct Static Pressure Probe
- Ambient Pressure

For more details on wiring the zone coordinator to each control point, follow the wiring diagrams starting on page 16 of this installation manual.

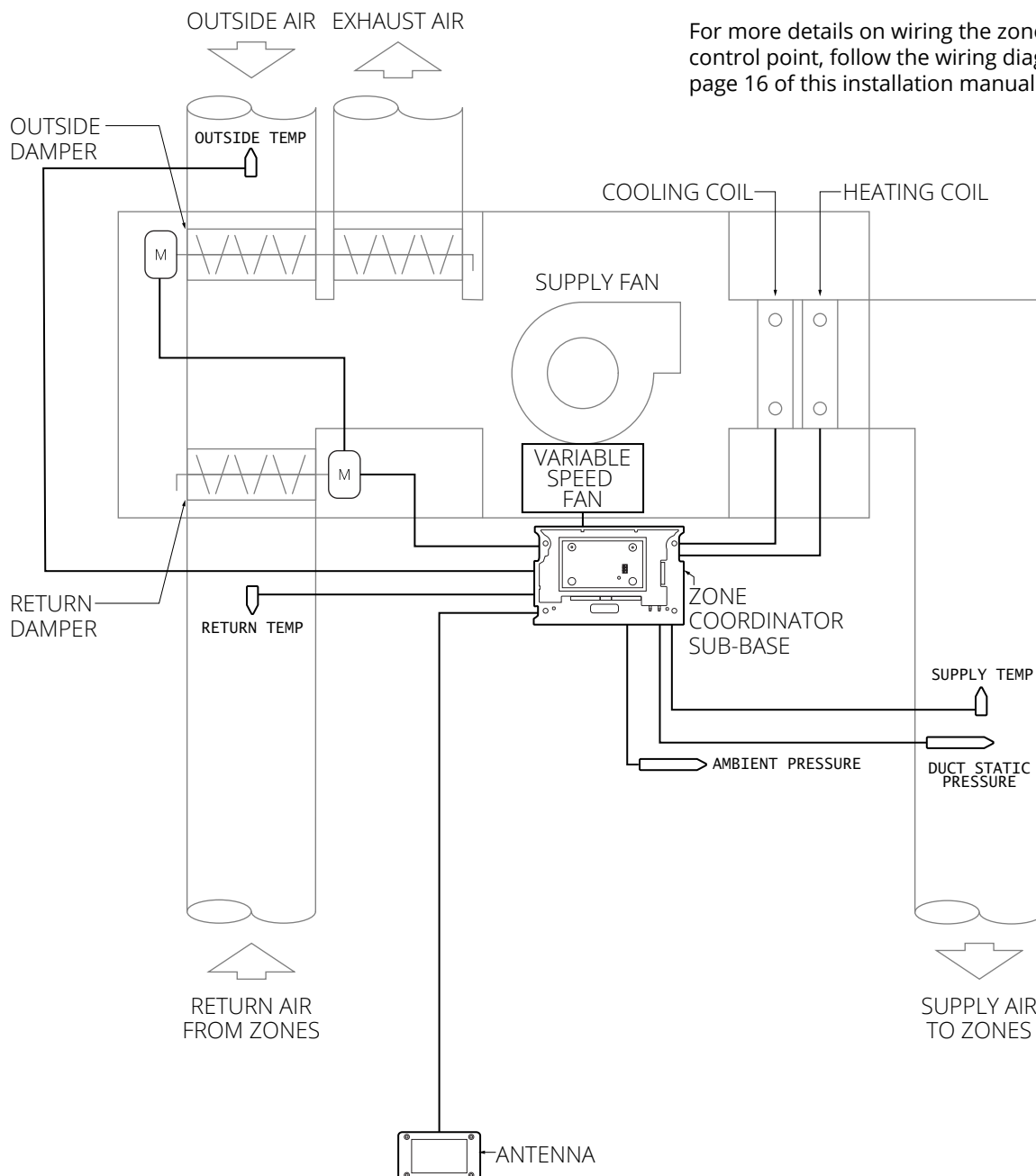

Planning - Different Mechanical Systems - Mixing Box / Multi-Zone (MB-CAV and MB-VAV)

Mixing Box Multi-Zone (MB-CAV and MB-VAV)

A mixing box/multi-zone system typically consists of a single air handler with both a cooling and ventilation supply duct and a separate heating supply duct. Some systems may also have a third bypass duct. The air handler provides either constant air (MB-CAV) or uses a variable speed fan (MB-VAV) to balance the airflow going to zones. Each zone has mechanically linked dampers mounted to a single actuator. A Pelican thermostat adjusts these dampers to provide air from either the cold deck or the hot deck. The dampers are designed to operate in reverse of each other, so when the cold deck is open, the hot deck is closed, and vice versa.

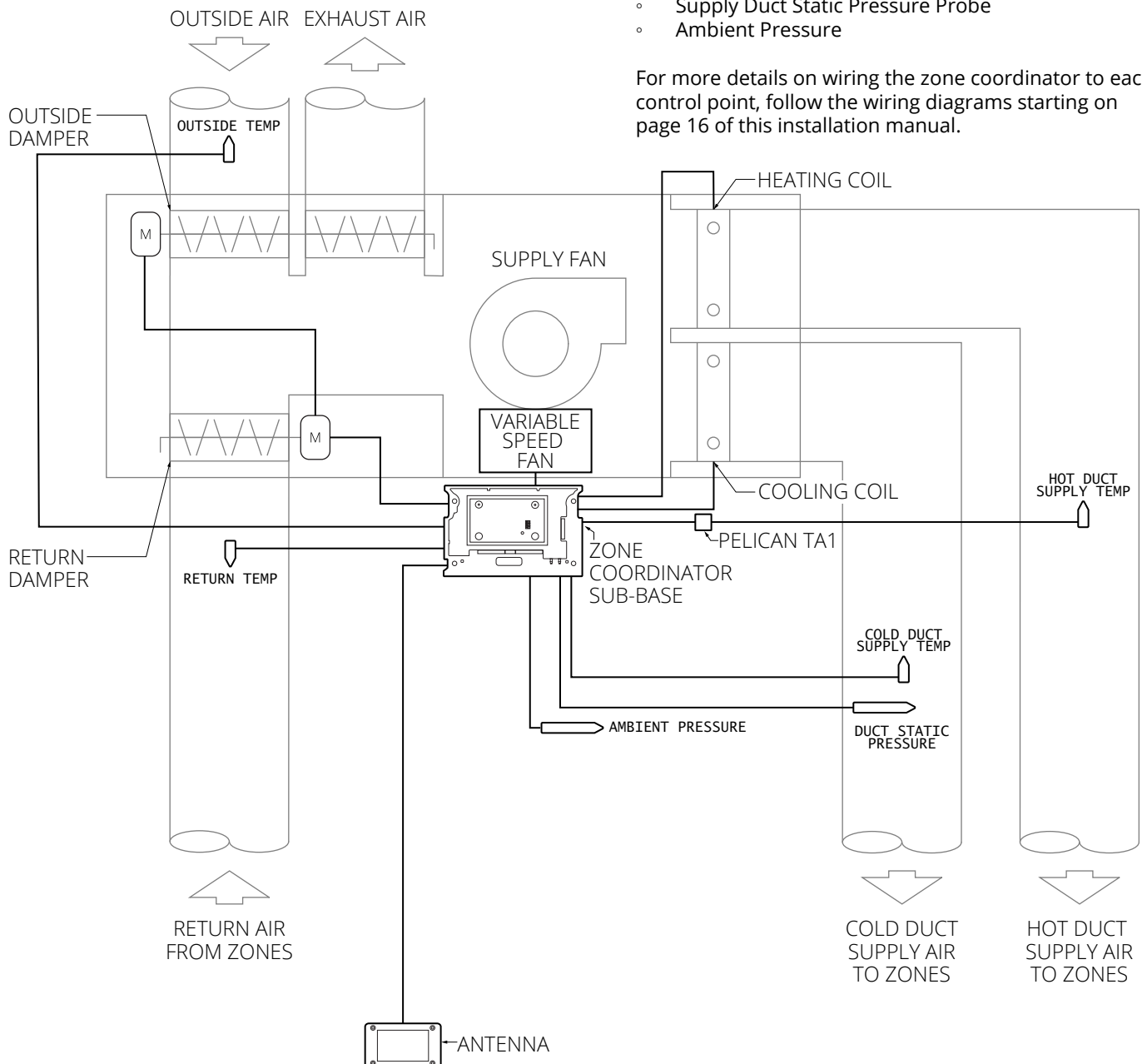

Requirements for Central Equipment Control

One zone coordinator will be required. The zone coordinator will need to be wired to provide:

- Supply Fan Enable/Disable Control
- Supply Fan Variable Speed Modulation Control (if available)
- Outside, Return, Exhaust Damper Modulation Control
- Cooling Enable/Disable and/or Modulation Control
- Heating Enable/Disable and/or Modulation Control
- Cold Deck Supply Temperature Sensor
- Hot Deck Supply Temperature Sensor (Requires a Pelican TA1, sold separately)
- Return Duct Temperature Sensor
- Outside Air Temperature Sensor
- Supply Duct Static Pressure Probe
- Ambient Pressure

For more details on wiring the zone coordinator to each control point, follow the wiring diagrams starting on page 16 of this installation manual.

Planning - Different Mechanical Systems - Dual Duct (DD-VAV)

Dual Duct Variable Air Volume (DD-VAV)

A dual duct variable air volume (DD-VAV) system typically consists of two air handlers with separate ducts traveling from each air handler to multiple zones. One air handler provides cooling and ventilation to zones, while the second air handler provides heating and transfer air to zones. Both air handlers commonly have their own supply fans¹, with either a variable speed drive or a bypass damper that is modulated to maintain supply duct static pressure. Pelican thermostats control two separate cooling and heating dampers, each with its own actuator. These actuators operate independently, allowing the zone thermostat to open the cold duct for cooling and ventilation or the hot duct for heating and transfer air.

¹In some dual duct applications, a single supply fan is shared between both the hot and cold deck air handlers. In this situation, two Pelican zone coordinators can be configured to communicate with each other to coordinate fan demand and static pressure reset targets. Contact Pelican engineering support for further assistance.

Requirements for Central Equipment Control

Two zone coordinators will be required. One zone coordinator will need to be wired to the cold duct air handler to provide:

- Supply Fan¹ Enable/Disable Control
- Supply Fan Variable Speed Drive or Bypass Damper Modulation Control
- Outside, Return, Exhaust Damper Modulation Control
- Cooling Enable/Disable and/or Modulation Control
- Cold Supply Duct Temperature Sensor
- Return Duct Temperature Sensor
- Outside Air Temperature Sensor
- Supply Duct Static Pressure Probe
- Ambient Pressure

A second zone coordinator will need to be wired to the hot duct air handler to provide:

- Supply Fan¹ Enable/Disable Control
- Supply Fan Variable Speed Drive or Bypass Damper Modulation Control
- Heating Enable/Disable and/or Modulation Control
- Hot Supply Duct Temperature Sensor
- Return Duct Temperature Sensor
- Supply Duct Static Pressure Probe
- Ambient Pressure

For more details on wiring the zone coordinator to each control point, follow the wiring diagrams starting on page 16 of this installation manual.

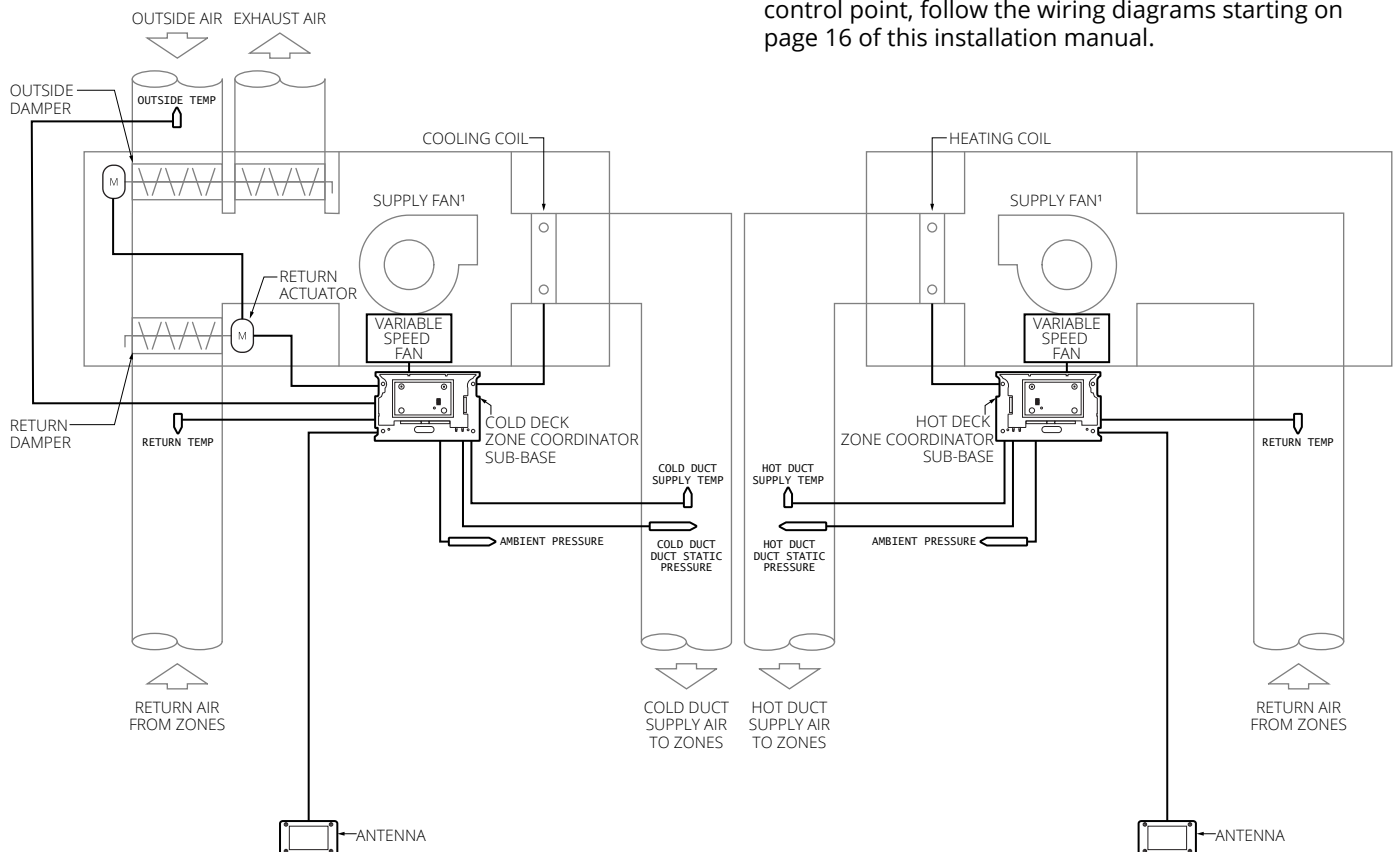

Planning - Wireless Networking

Scenario 1: Installing the Zone Coordinator Inside the Building

If the zone coordinator is installed inside the building, its antenna can usually remain mounted inside the controller's sub-base, provided it is not on or inside a metal enclosure.

If the zone coordinator is installed inside the building but is mounted on or inside a metal control panel or in a room with wireless interference, the antenna will need to be mounted outside the panel or room and wired back to the sub-base.

In some cases, even if the sub-base is installed inside the building, the antenna might be unable to connect to the wireless network. In such situations, it is best to mount the antenna in a location with a strong wireless network signal and use three wires to connect it back to the sub-base (see Scenario 2 on this page).

Scenario 2: Installing the Zone Coordinator Sub-Base at/Near the HVAC Equipment and the Antenna Inside the Building

If the zone coordinator's sub-base is installed inside or near the HVAC equipment, its antenna should be installed inside the building and wired back to the sub-base. This is because the metal and general construction found around HVAC equipment and the roof create wireless interference. For instructions on how to wire the antenna to the zone coordinator, refer to "Mounting and Wiring Antenna" on page 13.

It is always advised to mount the antenna inside the building to ensure a reliable wireless signal between the zone coordinator and the Pelican wireless network.

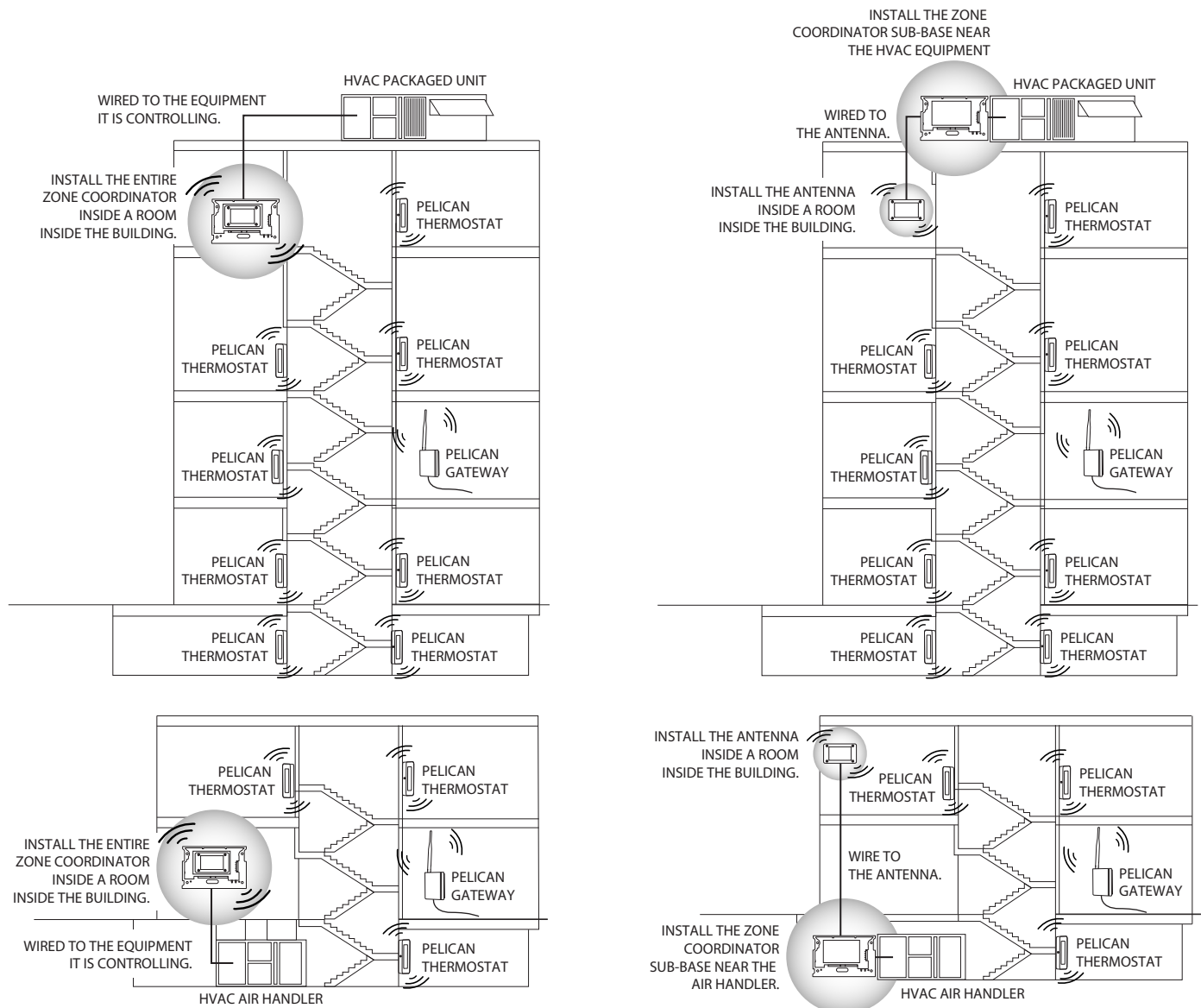

Mounting – Zone Coordinator Sub-Base

Scenario 3 (not recommended): Installing the Zone Coordinator Inside the HVAC Equipment and Mounting the Antenna on the Roof Outside of the Equipment

If the zone coordinator is installed inside the HVAC equipment's control panel, the antenna can be installed on a **PLASTIC** outdoor-rated single gang electric box (gasket required) mounted on the exterior of the equipment or somewhere on the roof away from the equipment. This would be considered a last resort option and is not advised due to the type of construction found around HVAC equipment, which creates wireless interference.

Because there is no guarantee, in this configuration, that the antenna will be able to communicate with the wireless network, it is always best to mount the antenna inside the building and wire it back to the sub-base (refer to Scenario 2 on page 11).

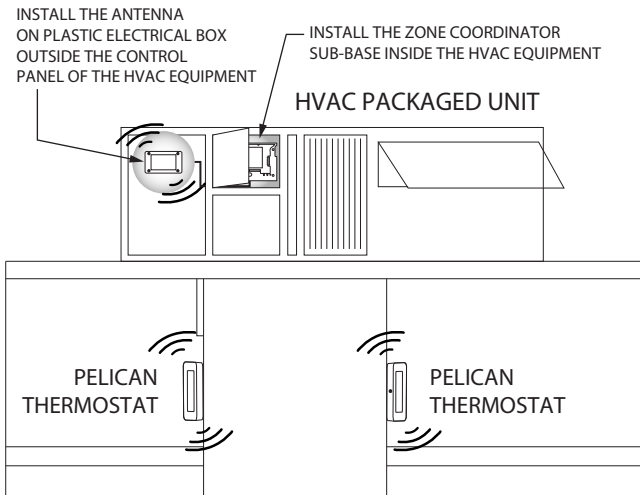

When installing the antenna on an outdoor-rated PLASTIC electric box, make sure to install the provided gasket between the antenna and the electrical box. This gasket is designed to prevent water from entering the electrical box and to protect against electrical damage.

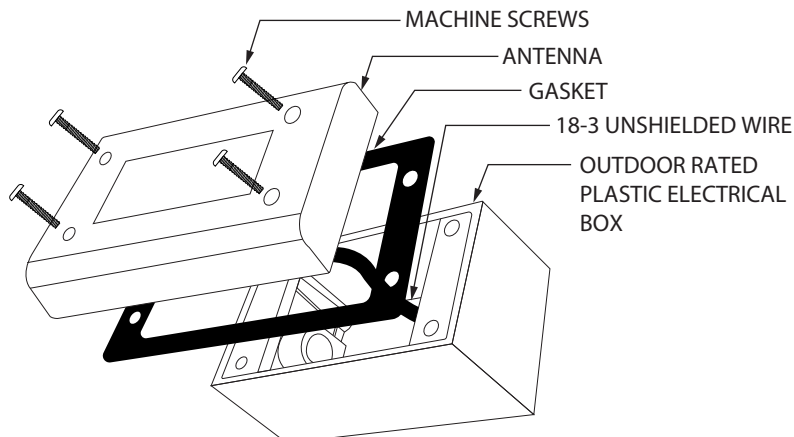

Remove the cover from the zone coordinator by gently pulling it from the sub-base. Use the best two of the four mounting holes on the zone coordinator's sub-base to mount it to a flat surface. Using the included 3/16" sheet metal screws, secure the sub-base to the surface.

If the sub-base is mounted on a metal surface, inside a metal control panel, inside an IDF or MDF room, or inside the HVAC equipment, you must mount the antenna in a separate location from the sub-base and then wire them together. For installation scenarios, reference pages 11 & 12. For instructions on how to mount and wire the antenna back to the sub-base, reference pages 13 & 14.

SUB-BASE

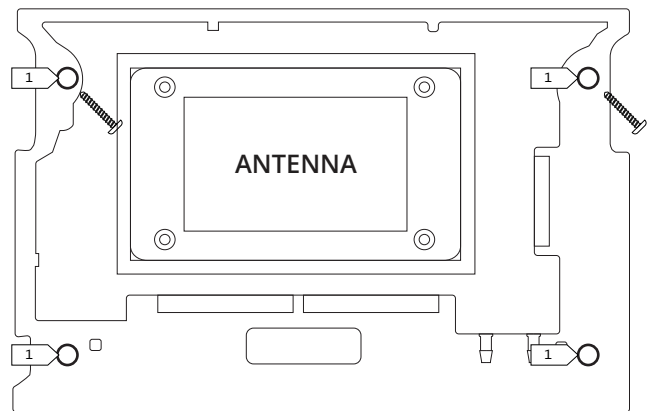

1 3/16" mounting holes.

Mounting and Wiring – Antenna

For more information on when to remove the antenna from the sub-base and for examples of where to install the antenna, refer to pages 11 & 12.

Step-by-Step Instructions:

Step 1: Remove the cover from the zone coordinator by gently pulling it off the sub-base. Next, remove the antenna from the sub-base by holding the sub-base and gently pulling the antenna away from the three-pin connector.

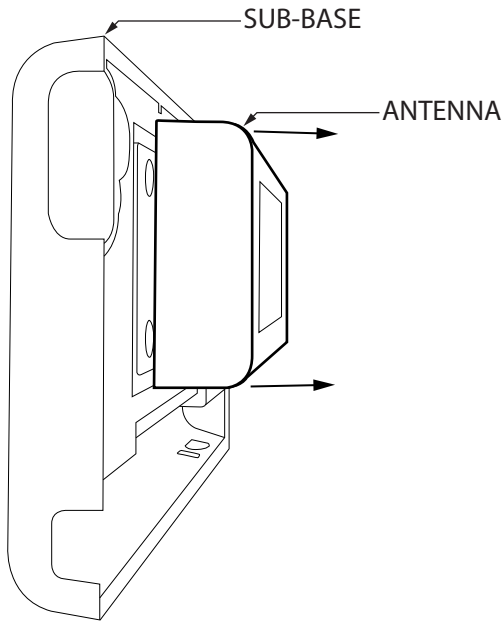

Step 2: Install one of the provided 3-pin connectors into the R, C, D terminal on the antenna. The connector will only fit in one orientation. Never force the connector, as this may cause damage.

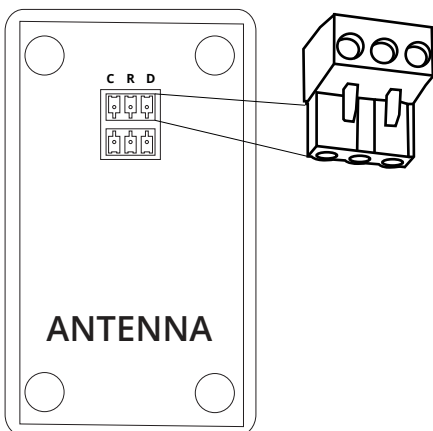

Insert plug and gently push it downward until it is fully seated inside the antenna's R, C, & D terminals.

Step 3: Mount the sub-base in a location where it can easily be wired to the HVAC equipment it will control.

Use the best two of the four mounting holes on the sub-base to secure it to a flat surface with the included 3/16" sheet metal screws.

SUB-BASE

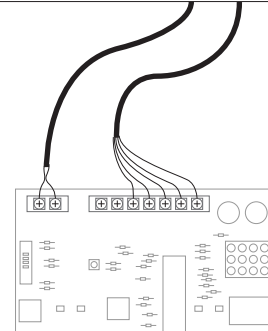
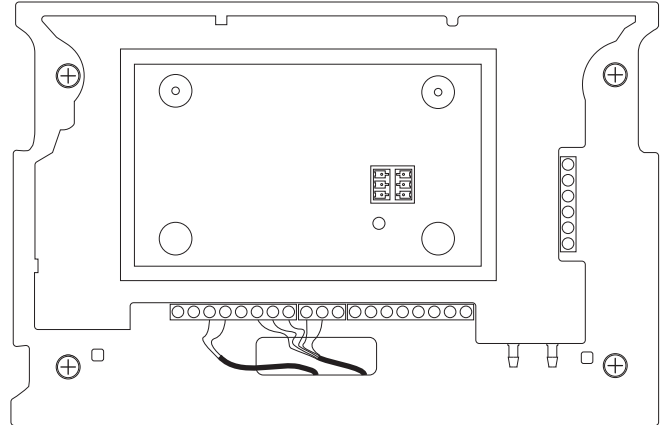

TYPICAL HVAC CONTROL BOARD

Step 4: Run new or use existing 18-3 unshielded thermostat wire between the antenna and the sub-base. The maximum wire length is 500 feet.

Mount the antenna in a location where it can communicate with the wireless mesh network. For antenna installation recommendations, refer to the installation scenarios on pages 11 & 12.

Wire the R, C, and D terminals at the antenna to the matching R, C, and D terminals at the sub-base.

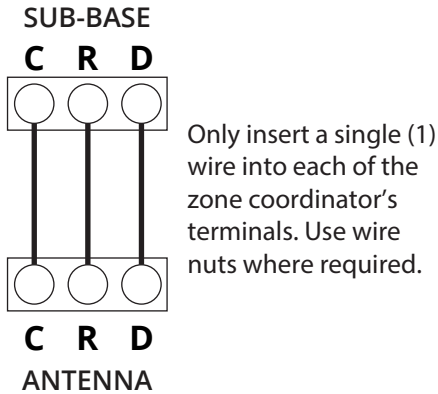

Step 5: Using the four mounting holes, secure the antenna to a non-metal surface. Ensure there are no metal objects that could obstruct the antenna's communication with the wireless mesh network.

ANTENNA

⊕ ⊕
PELICAN
Serial No: ###-####
⊕ ⊕

For the best wireless signal, the antenna should be mounted horizontally with the Pelican logo and serial number right-side up and legible. Clearly identify and track the antenna's installation location for future service.

Wiring - Power

The zone coordinator must be powered by a 24V AC Class 2 power source. Disconnect electrical power to the power source before wiring anything to the zone coordinator. Failure to follow this warning could result in electrical shock, personal injury, or damage to the controller. If you use a separate control power transformer, it is essential that either the auxiliary transformer and the HVAC equipment's transformer are in-phase, or isolation relays must be installed between the zone coordinator's 24V AC outputs and any inputs at the HVAC equipment. Verify this before connecting the auxiliary transformer to the zone coordinator.

IMPORTANT

Avoid connecting power to any inputs or outputs not specifically designated for power. Wiring power to the T1, T2, T3, A1, A2, A3, A4, S1, or S2 inputs can damage the controller. Exercise extreme caution when wiring power to the controller.

Using the Equipment's 24V AC Transformer:

- 1) Before wiring the zone coordinator to the equipment's power source, turn power ON to the equipment and verify that the voltage measured from the transformer is within the zone coordinator's operating range of 23 - 30V AC.
- 2) Turn power OFF to the equipment.
- 3) Wire the zone coordinator's R terminal to 24V AC and C terminal to Common at the equipment.
- 4) Turn power ON to the equipment and verify that the zone coordinator's Power & Internal Status LED begins blinking; "Start-Up: Sub-Base LED Lights: on pages 29 & 30.
- 5) Turn power OFF to the equipment and the zone coordinator to complete the installation.

Using an Auxiliary 24V AC Transformer:

- 1) Follow the transformer installation manual for directions on how to install the transformer.
- 2) Before wiring the zone coordinator to the transformer, turn power ON to the transformer and verify that the voltage measured is within the zone coordinator's operating range of 23 - 30V AC.
- 3) Turn power OFF to the transformer.
- 4) Wire the zone coordinator's R terminal to 24V AC and C terminal to Common at the transformer.
- 5) Turn power ON to the transformer and verify that the zone coordinator's Power & Internal Status LED begins blinking; "Start-Up: Sub-Base LED Lights: on pages 29 & 30.
- 6) Turn power OFF to the transformer and the zone coordinator to complete the installation.

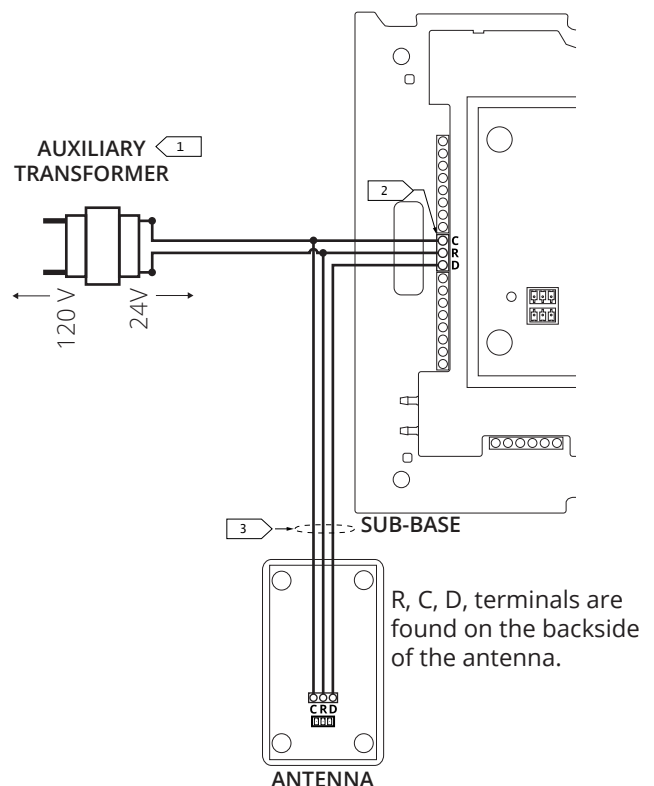
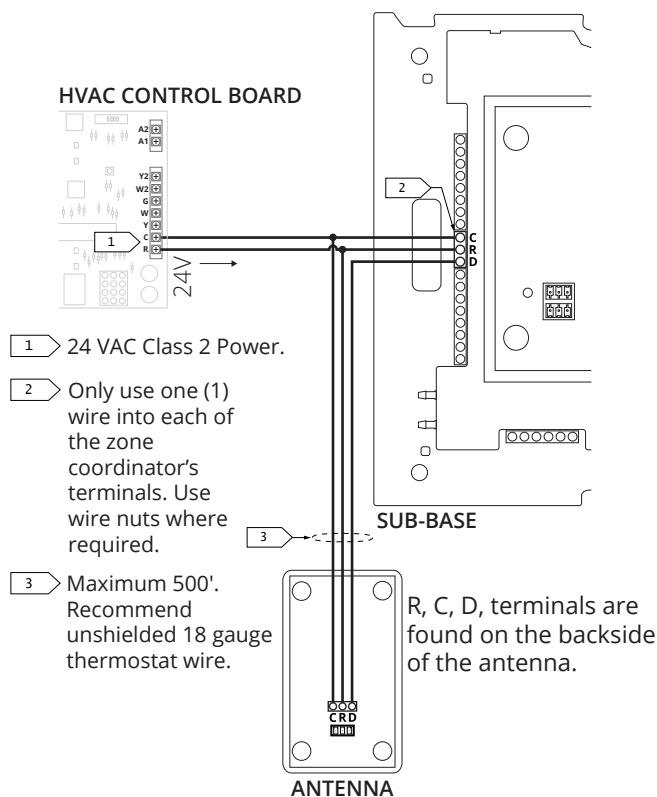

Wiring - Control Diagrams

The zone coordinator can be wired and configured to control a wide range of HVAC equipment. Refer to the different wiring diagrams for the most common mechanical systems on pages 16 to 23.

It is essential to follow these diagrams, as the controller's outputs are closely linked to their configured functions. Verify proper mechanical operation before and after installation and ensure that all configurations are accurate for your installation.

For installations outside of these diagrams, stop what you are doing and contact Pelican support for further assistance.

Mechanical Cooling Control:

- Staged Compressor (DX) Cooling
 - Conventional – Page 16
 - Heat Pump – Page 18
- Modulating Compressor (DX) Cooling
 - Conventional – Page 17
 - Heat Pump – Page 18
- Floating Chilled Water Valve – Page 19
- Modulating Chilled Water Valve – Page 19

Central Heating Control:

- Staged Gas Heat or Electric – Page 16
- Heat Pump Heating – Page 18
- Modulating Gas or Electric SCR – Page 17
- Modulating Heat Pump – Page 18
- Floating Hot Water Valve – Page 20
- Modulating Hot Water Valve – Page 20

Variable Static Pressure Control:

- Variable Speed Fan – Page 22
- Bypass Damper – Page 23

Outside Damper Control:

- Economizer & Ventilation – Pages 21 to 23

Hot Water Pump & Boiler Enable:

- Hot Water Pump & Boiler Enable – Page 21

Static Pressure Sensor Installation:

- Static Pressure Probe & Tubing – Page 26

Temperature Sensor Installations:

- Supply, Return, Outside Temps – Page 27

Conventional Cooling and Heating (1 to 3 stages each)

The zone coordinator will vary the number of active cooling and heating stages to maintain the desired discharge air temperature. In some applications, isolation relays are required where terminal blocks do not exist.

HVAC Equipment Terminals (Typical)

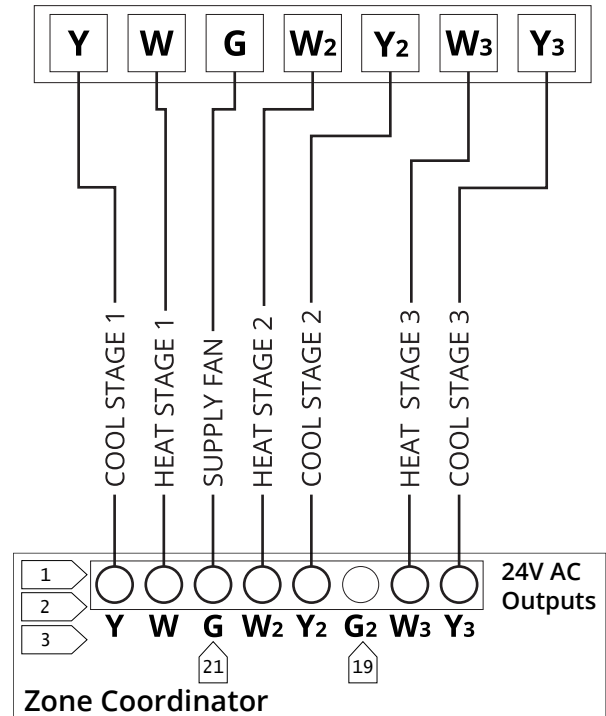

The below tables represent when each output will be energized:

Three (3) Cool Staging Sequence

	Y	Y2	Y3
Stage 1 Cooling			
Stage 2 Cooling			
Stage 3 Cooling			

Three (3) Heat Staging Sequence

	W	W2	W3
Stage 1 Heating			
Stage 2 Heating			
Stage 3 Heating			

■ Indicates that output will be enabled.

Conventional Cooling (with a modulating compressor)

In applications with a modulating compressor, it is common for the first compressor to be the one that modulates. The zone coordinator has a variety of supply target sequences for both modulating and staging compressors. For more information on sequences, refer to “Variable Temperature Linked to Staging” on page 46.

In some applications, isolation relays are required where terminal blocks do not exist.

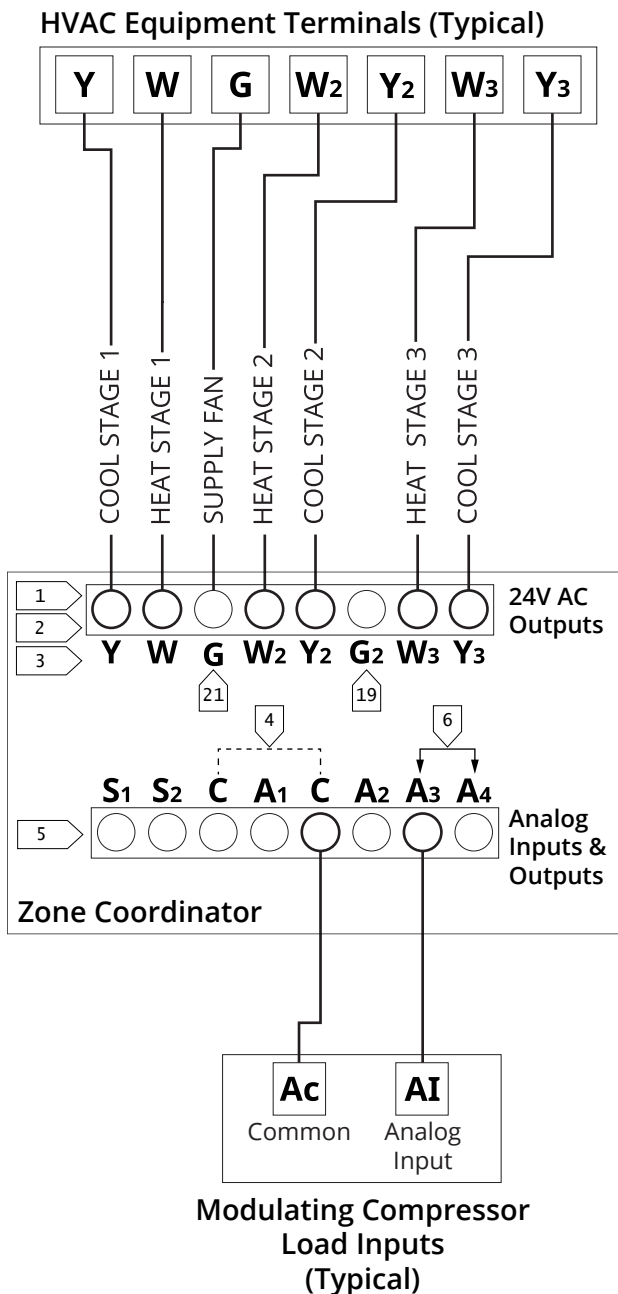

Conventional Heating (modulating furnace or electric heat)

In applications with modulating heat, it is common for the first burner or electrical element to be the one that modulates. The zone coordinator has a variety of supply target sequences for both modulating and staging heat. For more information on sequences, refer to “Variable Temperature Linked to Staging” on page 46.

In some applications, isolation relays are required where terminal blocks do not exist.

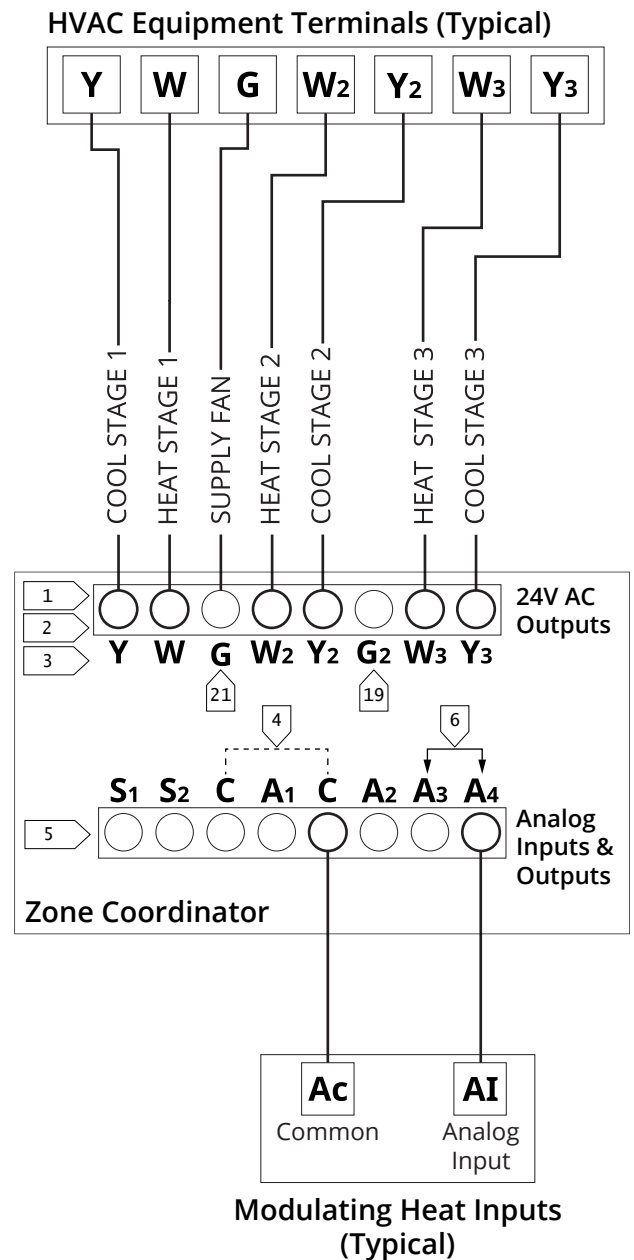

Heat Pump Cooling and Heating (1 to 3 stages each)

The zone coordinator will vary the number of active heat pump compressor stages to maintain the desired discharge air temperature. In some applications, isolation relays are required where terminal blocks do not exist.

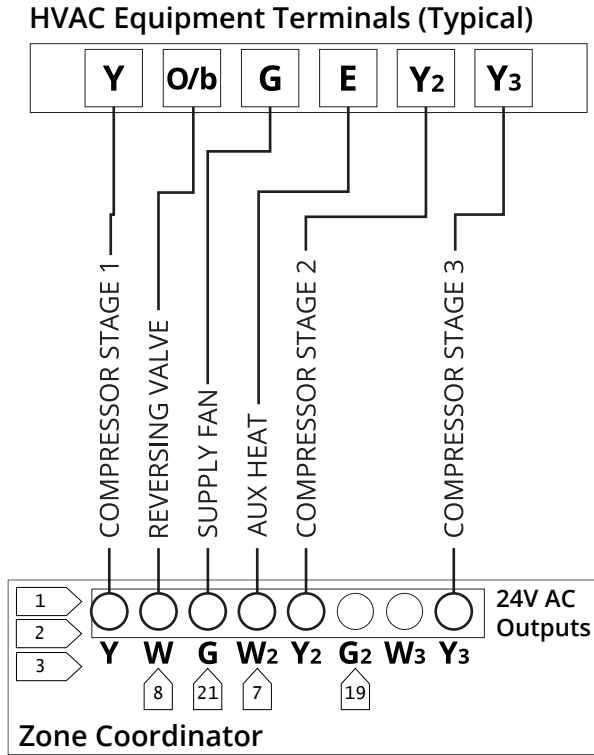

The below tables represent when each output will be energized:

Three (3) Compressor - Cool Staging Sequence

	Y	Y2	Y3	W
Stage 1 Compressor				◇
Stage 2 Compressor				◇
Stage 3 Compressor				◇

Three (3) Compressor - Heat Staging Sequence

	Y	Y2	Y3	W
Stage 1 Compressor				◇
Stage 2 Compressor				◇
Stage 3 Compressor				◇

■ Indicates that output will be enabled.

◇ Reference note 8.

Heat Pump Cooling and Heating (with a modulating compressor)

In applications where there is a modulating compressor, it is common for the first compressor to be the one that modulates. The zone coordinator has a variety of supply target sequences for both modulating and staging compressors. For more information on sequences, reference to "Variable Temperature Linked to Staging" on page 46.

In some applications, isolation relays are required where terminal blocks do not exist.

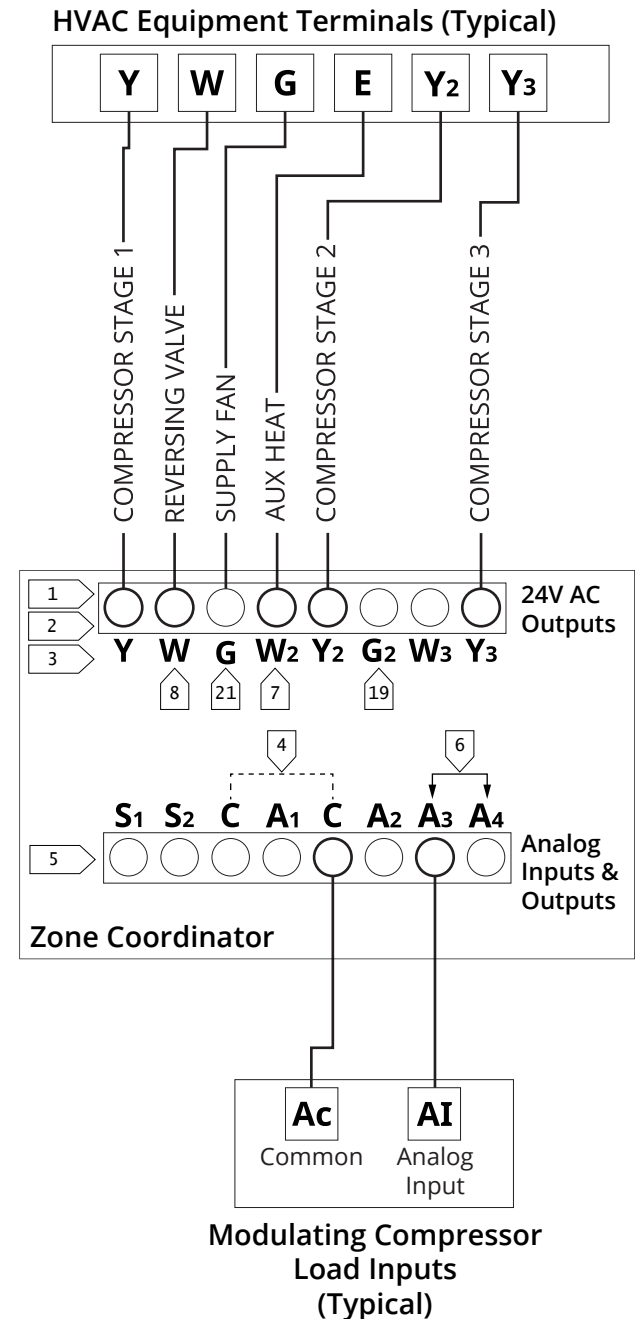

Chilled Water Valve (Floating or Two-Position)

In applications where there is a floating chilled water valve, the controller will vary the valve position to maintain a target discharge temperature. For two-position valves, the valve will operate from fully open to fully closed.

24 VAC Floating Valve Actuator (Typical)

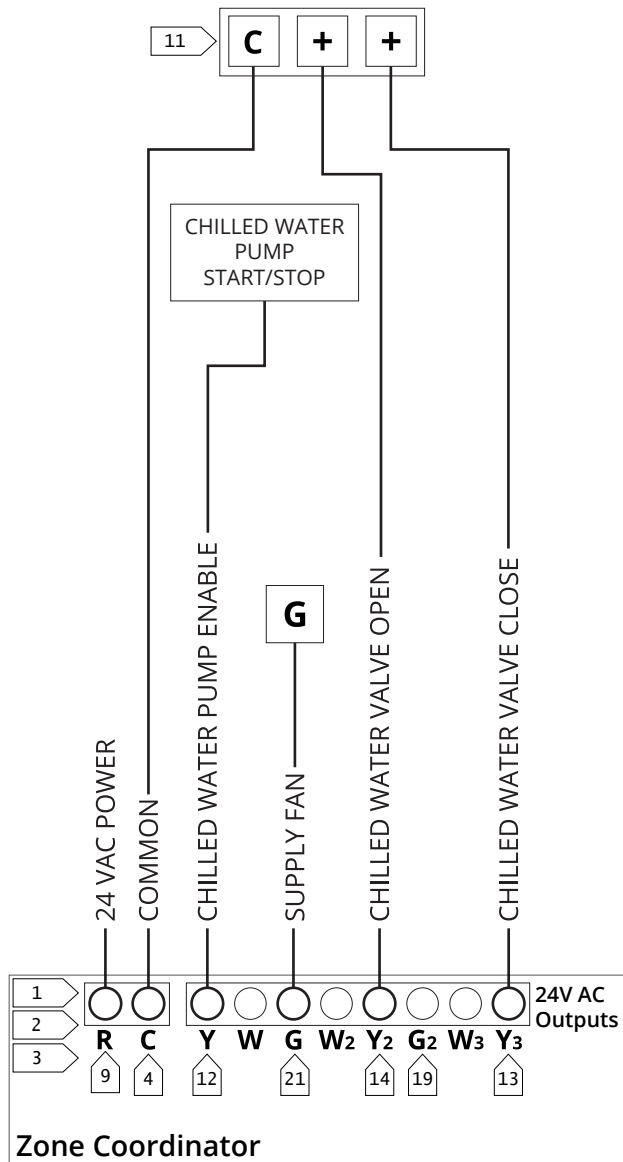

Chilled Water Valve (0[2]—10V DC modulating)

In applications where there is a modulating chilled water valve, the controller will vary the valve position to maintain a target discharge temperature.

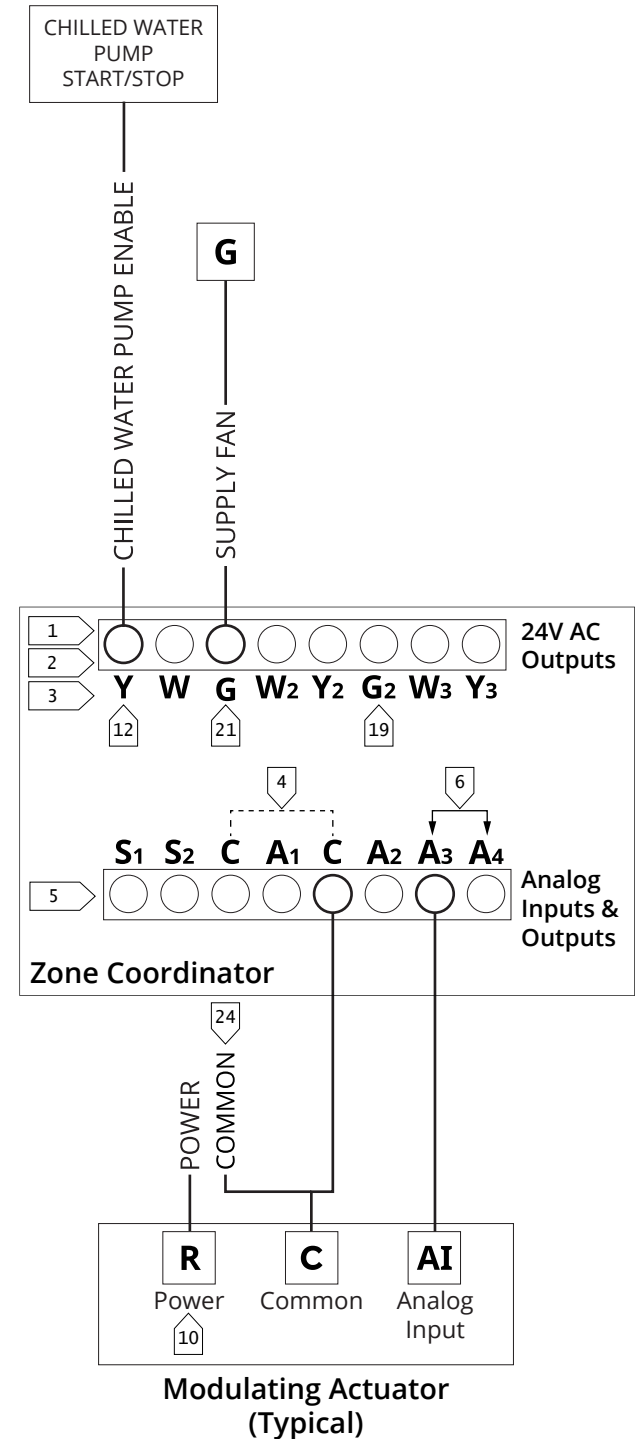

Hot Water Valve (Floating or Two-Position)

In applications where there is a floating hot water valve, the controller will vary the valve position to maintain a target discharge temperature. For two-position valves, the valve will operate from fully open to fully closed.

24 VAC Floating Valve Actuator (Typical)

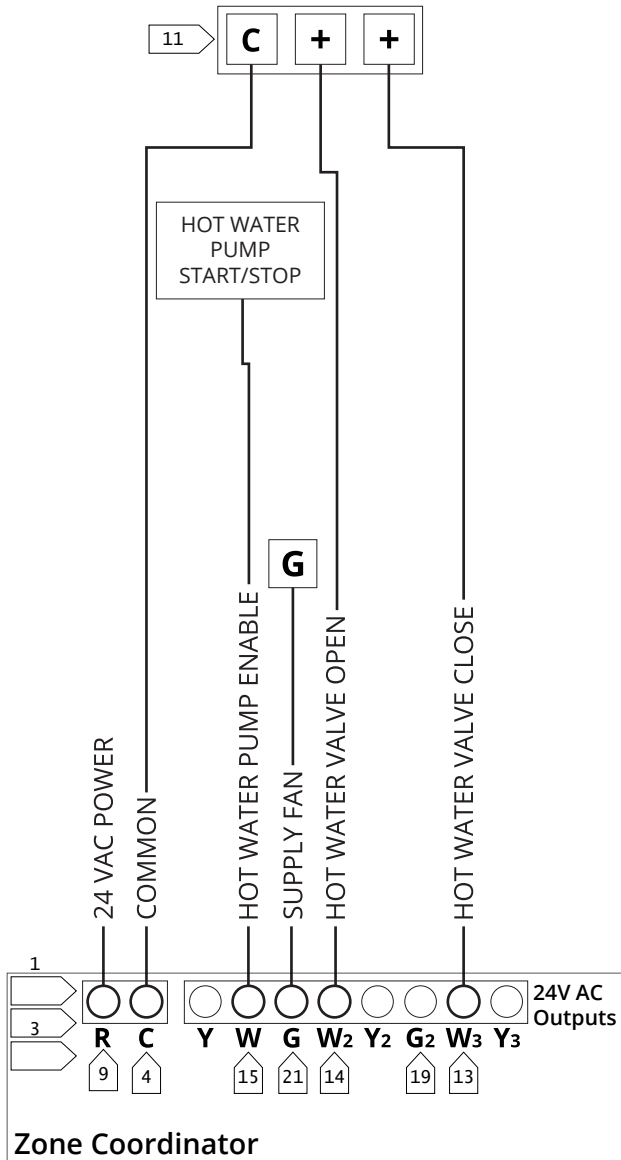

Hot Water Valve (0[2]—10V DC modulating)

In applications where there is a modulating hot water valve, the controller will vary the valve position to maintain a target discharge temperature.

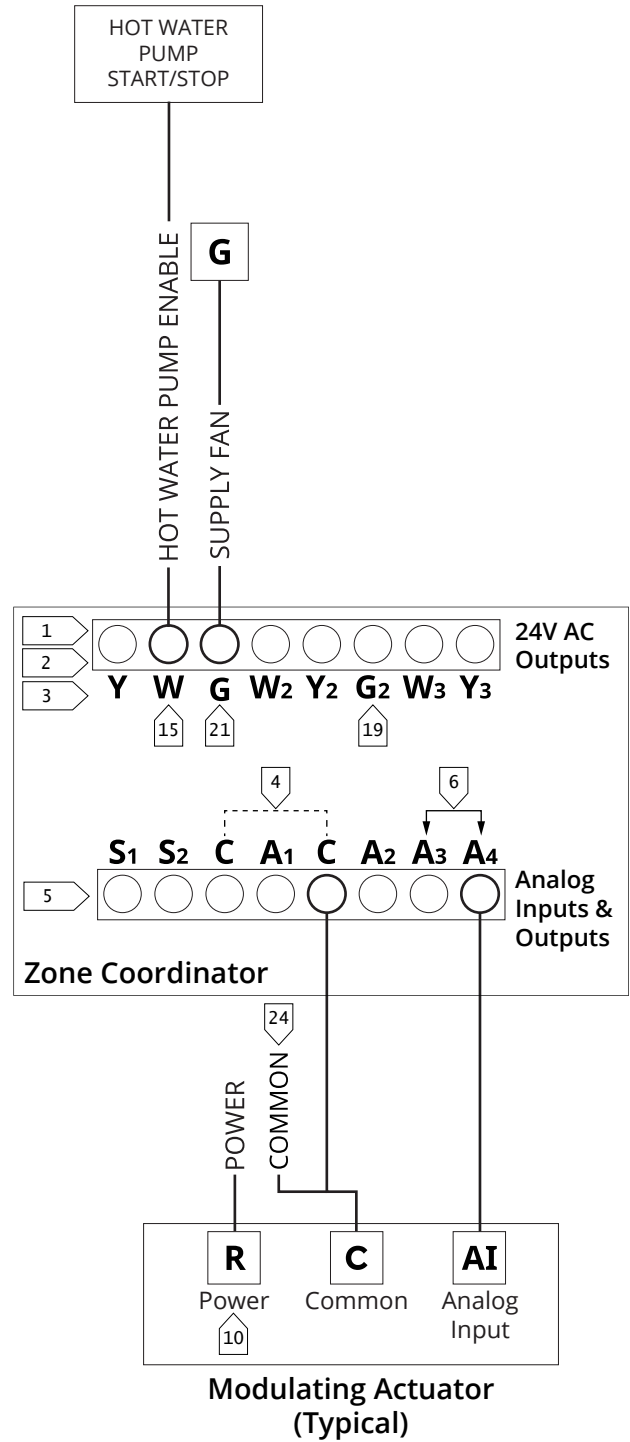

Dedicated Hot Water Boiler and Pump (Start/Stop with Temperature Interlock)

This diagram represents adding a sequence to enable and disable a dedicated hot water pump and boiler that supplies hot water to either the HVAC equipment's hot water coil or to the HVAC equipment's terminal boxes reheat hot water coils (typically found in VAV applications). For more information on sequences, reference "Boiler Controller" on page 46. Do not use this in applications where the boiler provides hot water to multiple air handlers.

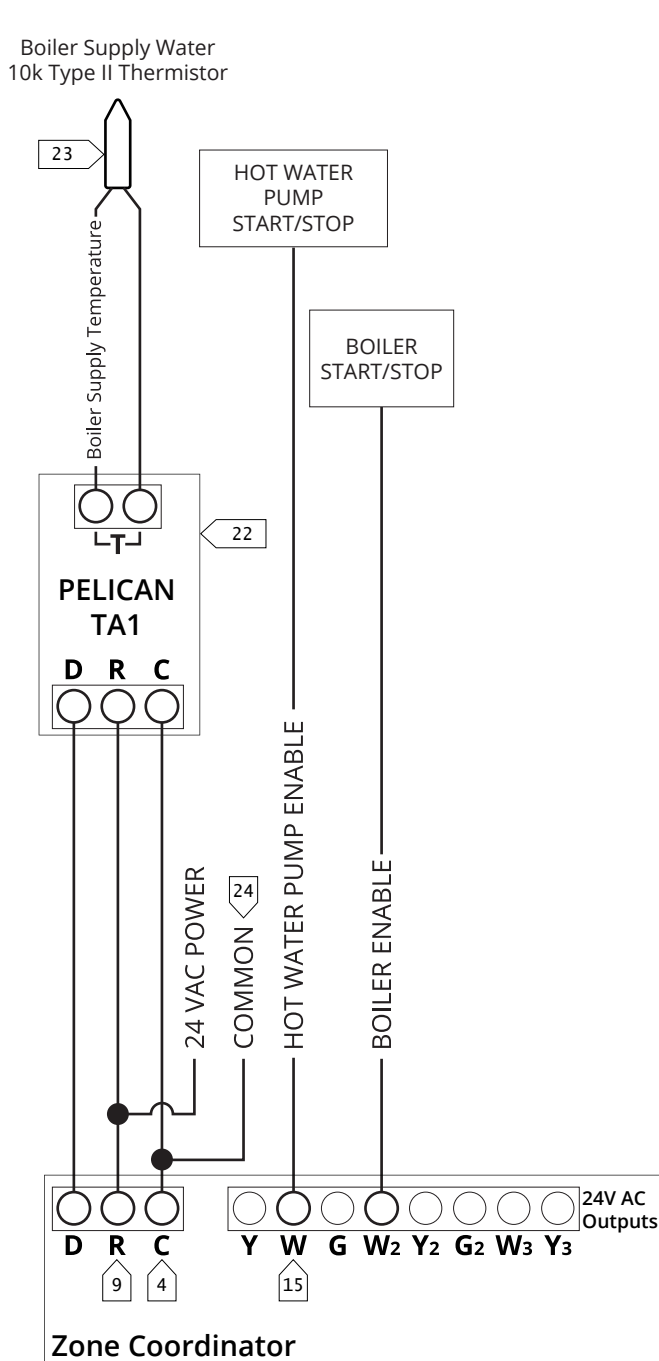

Outside Air Damper Control (0[2]—10V DC modulating)

In applications where there is a modulating outside damper, the controller will vary the position to maintain ventilation rates and sequences for economization.

IMPORTANT: Do not follow this wiring diagram if the zone coordinator is controlling a bypass. Follow the diagram "Bypass Damper & Outside Damper Control" on page 23.

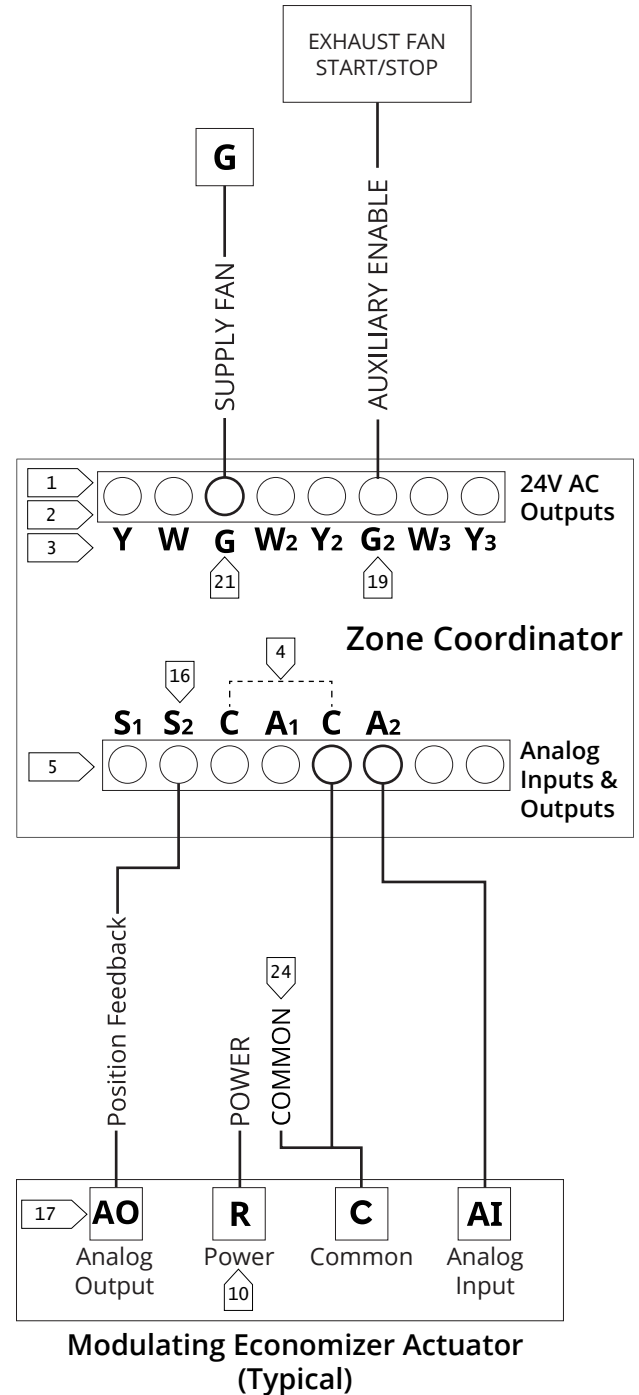

Variable Speed Fan & Outside Air Damper Control (0[2]—10V DC modulating)

In applications where there is a variable speed supply fan, the controller will adjust the fan speed to maintain different static pressures as it transitions between heating, cooling, and ventilation cycles. This diagram shows a start/stop isolation relay for the VFD. In ECM applications, this relay usually does not exist, and the supply fan is enabled through a 24V AC signal to the G terminal at the HVAC low voltage control panel. Static pressure targets are set in the zone coordinator configurations. For more information on static pressure sequences, reference “Static Pressure Targets” on page 37. It is important that the controller reads the correct supply duct static pressure. Reference “Install - Differential Pressure Sensor” on page 26 for how to install the static pressure probe and tubing. As the controller adjusts the static pressure, it will also automatically adjust the outside damper position to maintain minimum ventilation rates. It is important that the controller is wired to control both the fan speed and the outside damper position.

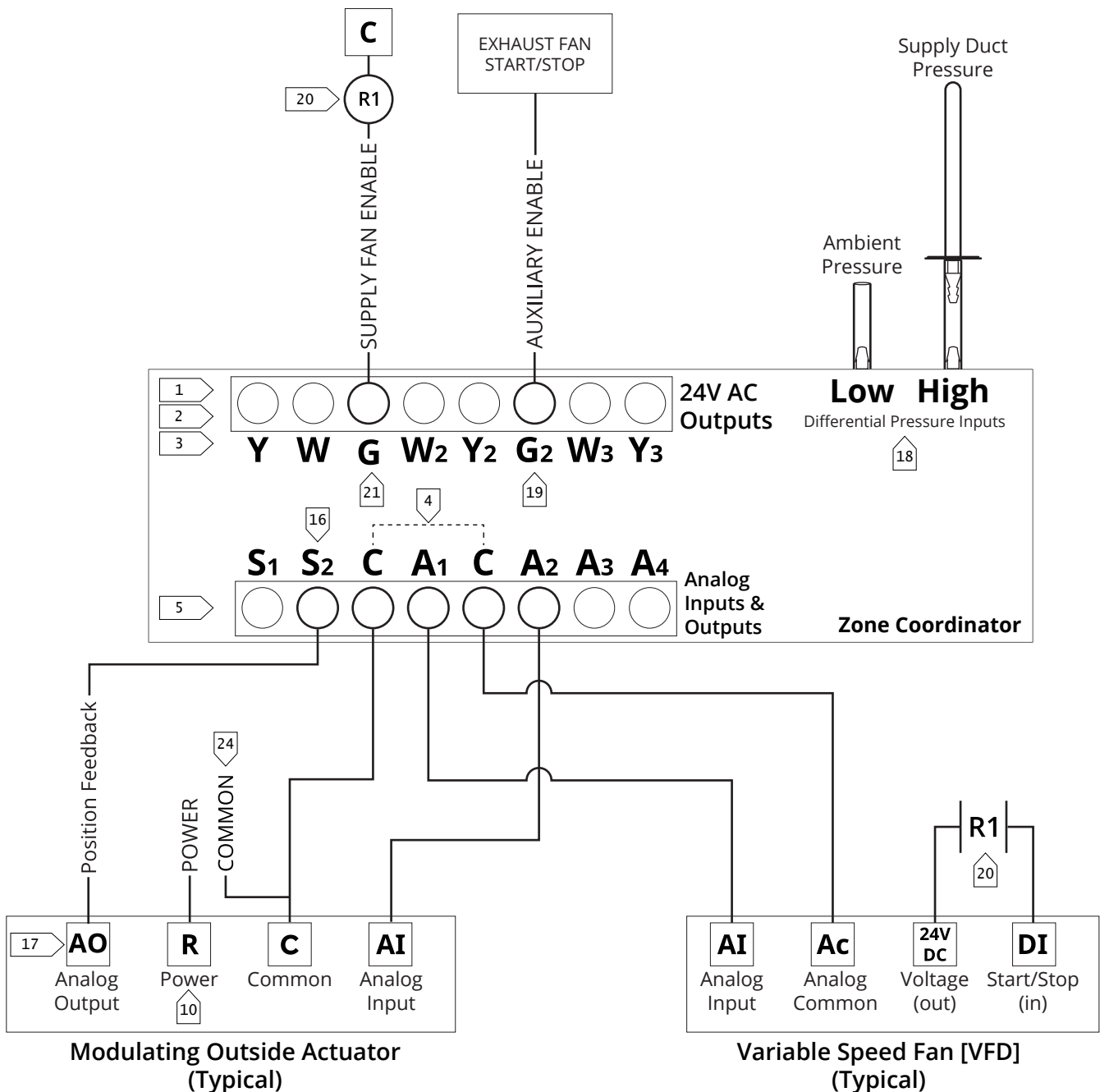

Bypass Damper & Outside Air Damper Control (0[2]—10V DC modulating)

In applications where there is a bypass damper or there are inlet vanes, the controller will adjust the damper position to maintain different static pressures as it transitions between heating, cooling, and ventilation cycles. For more information on static pressure sequences, reference "Static Pressure Targets" on page 37. Static pressure targets are set in the zone coordinator configurations. It is important that the controller reads the correct supply duct static pressure. Reference "Install - Differential Pressure Sensor" on page 26 for how to install the static pressure probe and tubing. As the controller adjusts the static pressure, it will also automatically adjust the outside damper position to maintain minimum ventilation rates. It is important that the controller is wired to control both the bypass or inlet vane dampers and the outside damper position.

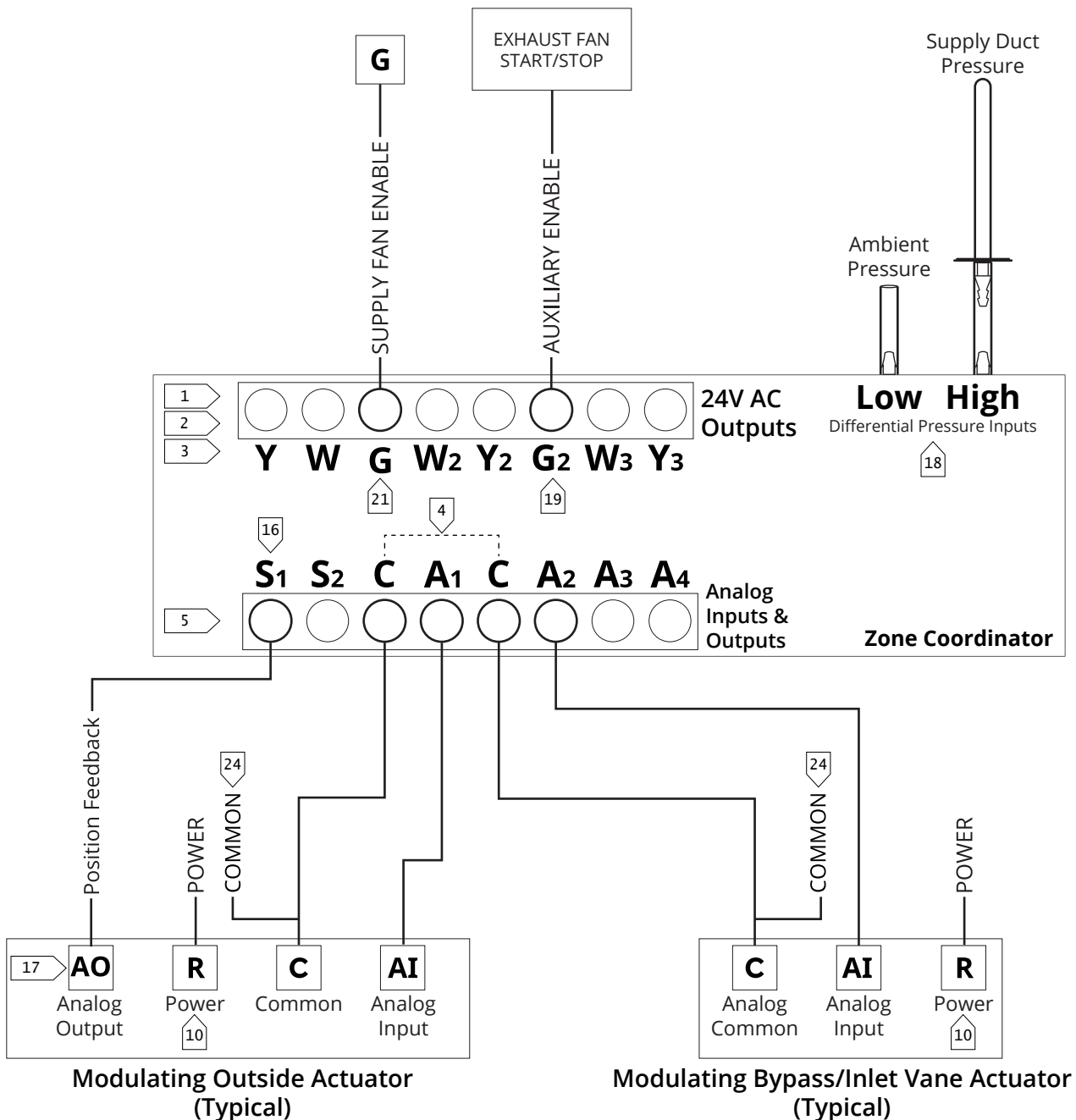

Notes

- 1 Outputs are 24V AC latching relays rated for max 2 amps continuous load.
- 2 All wire to be installed in accordance with local electrical codes. Only one wire per terminal. Use wire nuts where needed.
- 3 Recommend using 18 gauge unshielded thermostat wire.
- 4 All C terminals are internally connected.
- 5 Analog outputs are 0[2]—10V DC.
- 6 Either A3 or A4 can be configured to control the modulating heating or cooling sequence. The diagram shows the most common wiring.
- 7 There are multiple configurations for how Auxiliary Heat will be used as supplemental heat. Reference “Heat Pump Operation” on page 44.
- 8 The W output can be configured to energize the reversing valve during a cooling [O] or heating [b] cycle. Once energized, it will remain energized until the opposite sequence occurs.
- 9 24V AC Class 2 power only. Reference pages 15 for instructions on how to power the controller.
- 10 Follow actuator manufacturer’s installation and operation manual for power requirements. Power to actuator can be different than power to controller since they are isolated.
- 11 Actuator power to be 24V AC and to not exceed 2A running. Size power source to accommodate controller and actuator(s) at required VA when operating.
- 12 The Y output can be used to enable/disable a dedicated chilled water pump or any other equipment needed to run during the cooling cycle. A normally-open isolation relay is normally required to isolated this equipment start/stop from the controller power source.
- 13 Not required for actuators which spring-close.
- 14 Not required for actuators which spring-open.
- 15 The W output can be used to enable/disable a dedicated hot water pump or any other equipment needed to run during the heating cycle. A normally-open isolation relay is normally required to isolated this equipment start/stop from the controller power source.
- 16 Analog input is 0[2]—10V DC.
- 17 Required to meet California Title 24 Fault Detection and Diagnostics.
- 18 Reference page 26 for static pressure tubing and probe installation instructions.
- 19 The G2 output energizes during an economizer and demand ventilation cycle. For more information on sequences, reference “Economizer” and “Power Exhaust and/or Recovery Wheel” on pages 40.
- 20 A field installed 24V AC single-pole / single-throw isolation relay may be required for your installation. Follow manufacturer’s installation and operation manual for input requirements.

- 21 The G output will be enabled for all cooling compressor cycles, ventilation or fan cycles, and central heat or reheat cycles. For conventional systems, (e.g. gas furnaces) G will only enable during central heating if configured to do so. Reference "System Settings: Heat Needs Fan" configuration on page 31 for options.
- 22 A Pelican TA1 (sold separately) is required for this application. Wire the TA1's R, C, D power and communication terminals to the zone coordinators R, C, D power and communication terminals.
- 23 A 10K Type 2 thermistor is required for this application. Wire to the TA1's [T] terminals.
- 24 All Commons can be wired together. Only isolate if required by the device manufacturer.

Install - Differential Pressure Sensor

For the zone coordinator to operate, a supply duct static sensor is required for every installation. This includes applications that have constant volume supply fans.

The zone coordinator uses the static pressure probe for multiple functions

1. **Proof the fan is active.**
2. **Proof of sufficient airflow** moving across the different heating and cooling coils.
3. **Tracks and resets static pressure** in relation to zone's needs.
4. **Makes adjustments** to the bypass, variable speed fan, or other mechanical devices, allowing for an increase or decrease in the duct static pressure.

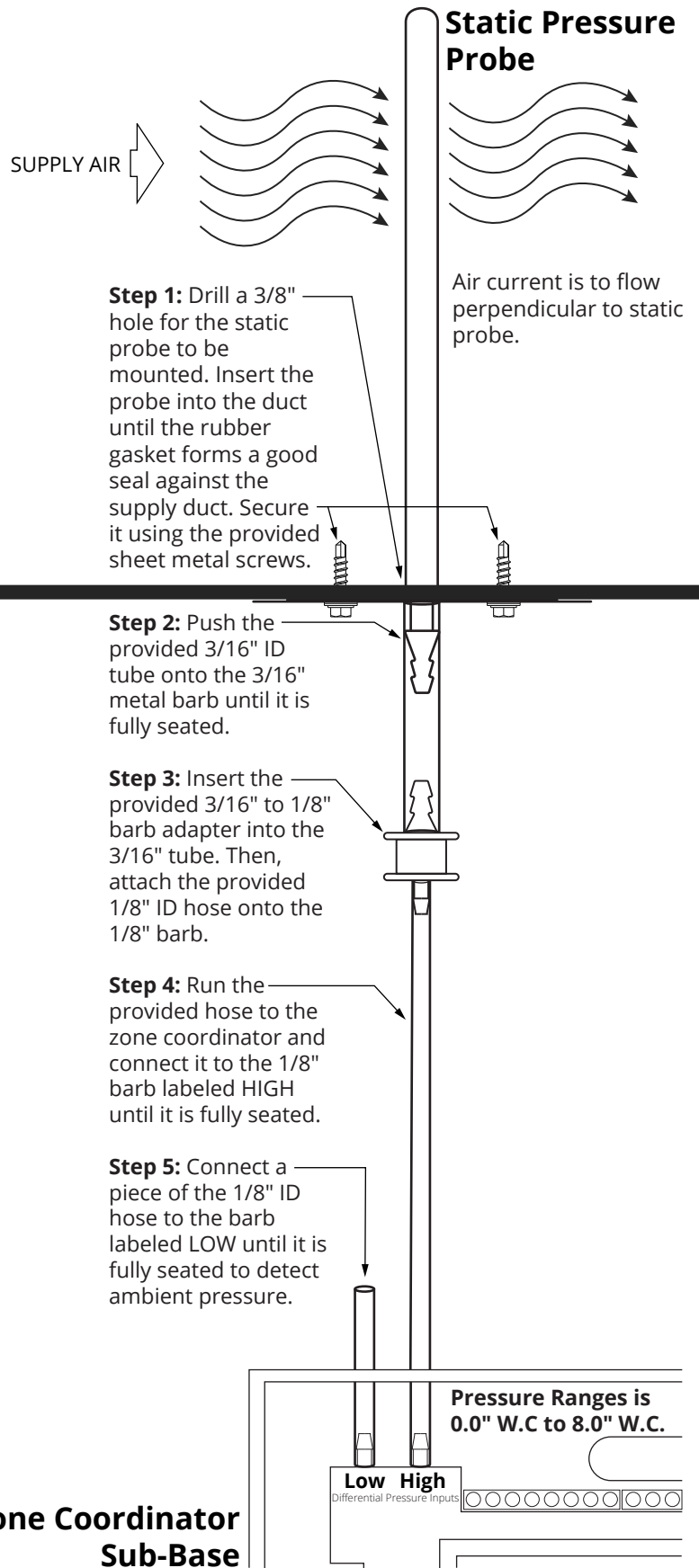

Main Supply Air Duct
Install the static pressure probe into a straight portion of the duct, at least one-third of the way down the main supply duct. Avoid installing it close to any bends or turns.

Zero Calibration
Upon initial power, the controller will zero calibrate its static pressure reading. It is essential that at this time, the fan is **OFF** and has not been manually overridden, as this would lead to inaccurate calibration. For further assistance, please contact Pelican technical support.

Zone Coordinator Sub-Base

Wiring - Temperature Sensors

For the zone coordinator to operate correctly, a supply, return, and outside temperature sensor is required for every installation.

Outside Air Temperature Probe:

IMPORTANT: The outside sensor must be installed where external radiant loads will not affect its temperature readings.

Step 1: Mount the probe where it can detect the outside temperature around the equipment.

Step 2: Use 2-18G wire² to connect the outside probe to the T3 terminal at the zone coordinator. Max wire length is 100 feet.

Return Air Temperature Probe:

Step 1: Drill a 1/4" hole into the duct for the probe to mount into.

Step 2: Push the probe into the duct until seated against the return duct and secure in place with the provided sheet metal screws.

Step 3: Use 2-18G wire² to connect the return probe to the T2 terminal at the zone coordinator. Max wire length is 100 feet.

Supply Air Temperature Probe:

Step 1: Drill a 1/4" hole into the duct for the probe to mount into.

Step 2: Push the probe into the duct until seated against the supply duct and secure in place with the provided sheet metal screws.

Step 3: Use 2-18G wire² to connect the supply probe to the T1 terminal at the zone coordinator. Max wire length is 100 feet.

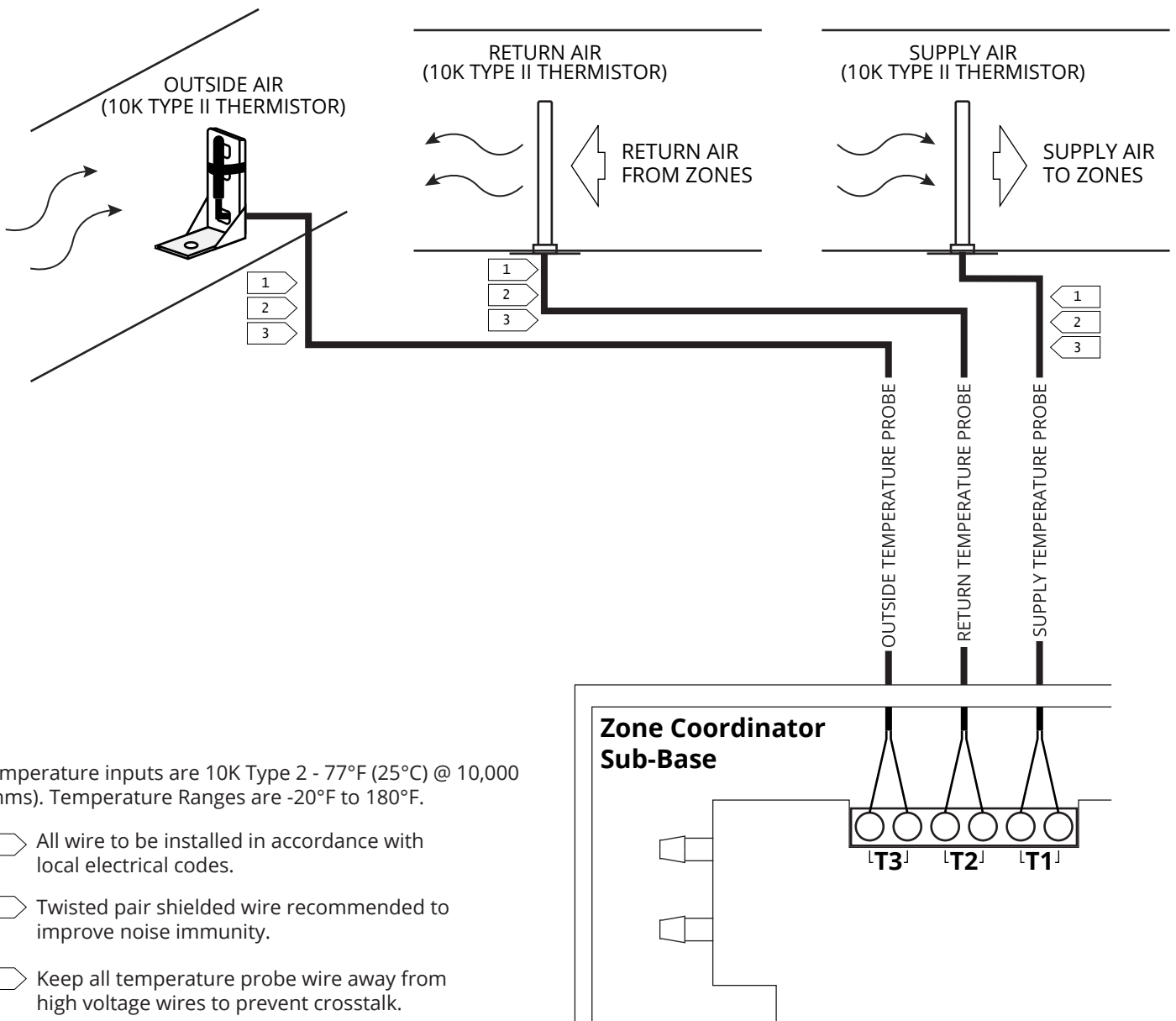

Temperature inputs are 10K Type 2 - 77°F (25°C) @ 10,000 Ohms). Temperature Ranges are -20°F to 180°F.

- 1 All wire to be installed in accordance with local electrical codes.
- 2 Twisted pair shielded wire recommended to improve noise immunity.
- 3 Keep all temperature probe wire away from high voltage wires to prevent crosstalk.

Before Start-up

To configure the controller, it must be connected to the Pelican wireless network and the network must have a Pelican gateway to connect everything to the Internet.

Before start-up, verify the following are installed and wired to the zone coordinator:

Required. . .	Provides. . .	Reference Page. . .
Cooling Control – The controller is wired to enable & disable stages and/or modulate central cooling.	<ul style="list-style-type: none"> ◦ Cool Supply Temperature Reset. ◦ Proof of Cooling Active. ◦ Temp Out-Of-Range Alarms. ◦ Historical Data Log. 	Mech Diagrams: 7 – 10 Wiring Diagrams: 16 – 21 Configurations: 31 – 36 Sequences: 37 – 47
Central Heating Control (as required) – The controller is wired to enable & disable stages and/or modulate the central heating.	<ul style="list-style-type: none"> ◦ Heat Supply Temperature Reset. ◦ Proof of Heating Active. ◦ Temp Out-Of-Range Alarms. ◦ Historical Data Log. 	Mech Diagrams: 7 – 10 Wiring Diagrams: 16 – 21 Configurations: 31 – 36 Sequences: 37 – 47
Static Pressure Control – The controller is wired to enable & disable the supply fan and modulate to maintain supply static pressure.	<ul style="list-style-type: none"> ◦ Static Pressure Reset. ◦ Anticipated Reset. ◦ Historical Data Log. 	Mech Diagrams: 7 – 10 Wiring Diagrams: 22, 23, 26 Configurations: 31 – 36 Sequences: 37 – 47
Static Pressure Reading – The controller is properly connected to read the supply duct's static pressure.	<ul style="list-style-type: none"> ◦ Static Pressure Adjustments. ◦ High/Low Static Resets ◦ Proof of Fan Active. ◦ Static Out-Of-Range Alarms. ◦ Historical Data Log. 	Mech Diagrams: 7 – 10 Wiring Diagrams: 26 Configurations: 31 – 32 Sequences: 37
Outside Damper Control – The controller is wired to modulate the outside damper and for California T24 it has position feedback.	<ul style="list-style-type: none"> ◦ Minimum Ventilation Rates. ◦ Demand Ventilation Rates. ◦ Ventilation to Static Reset. ◦ Mix Air w/ Low Limit Prevention. ◦ Economizer Free Cooling Logic. ◦ Fault Detection & Diagnostics. ◦ Fault Notifications. ◦ Historical Data Log. 	Mech Diagrams: 7 – 10 Wiring Diagrams: 21 – 23 Configurations: 32 Sequences: 39 & 42
Supply Temperature Sensor – The controller is wired to a 10K Type 2 thermistor installed in the supply duct and is reading accurate temperatures.	<ul style="list-style-type: none"> ◦ Supply Temperature Reset. ◦ Mixed/Supply Air Low Limit. ◦ Mixed/Supply Air High Limit. ◦ Proof of Cooling/Heating Active. ◦ Notifications. ◦ Historical Data Log. 	Mech Diagrams: 7 – 10 Wiring Diagrams: 27 Configurations: 34 Sequences: 38 – 47
Return Temperature Sensor – The controller is wired to a 10K Type 2 thermistor that is installed in the return duct and is reading accurate temperature.	<ul style="list-style-type: none"> ◦ ΔT Supply Temperature Reset. ◦ Economizer Differential Logic. ◦ Notifications. ◦ Historical Data Log. 	Mech Diagrams: 7 – 10 Wiring Diagrams: 27 Configurations: 34 Sequences: 38 – 47
Outside Temperature Sensor – The controller is wired to a 10K Type 2 thermistor that is installed where it can read an accurate outside air temperature.	<ul style="list-style-type: none"> ◦ Mixed/Supply Air Low Limit. ◦ Economizer Differential Logic. ◦ Low Limit OSA Compressor Lock-Out. ◦ Notifications. ◦ Historical Data Log. 	Mech Diagrams: 7 – 10 Wiring Diagrams: 27 Configurations: 34 Sequences: 39

Start-Up: Sub-Base LED Lights

The zone coordinator needs 24V AC power, reference “Wiring - Power” on page 15, to begin its start-up process. There are two LED lights located on the sub-base to the left of the Y terminal. These LEDs provide feedback on power-up and wireless connectivity. Both LEDs must be solid green before moving on to configuring the device.

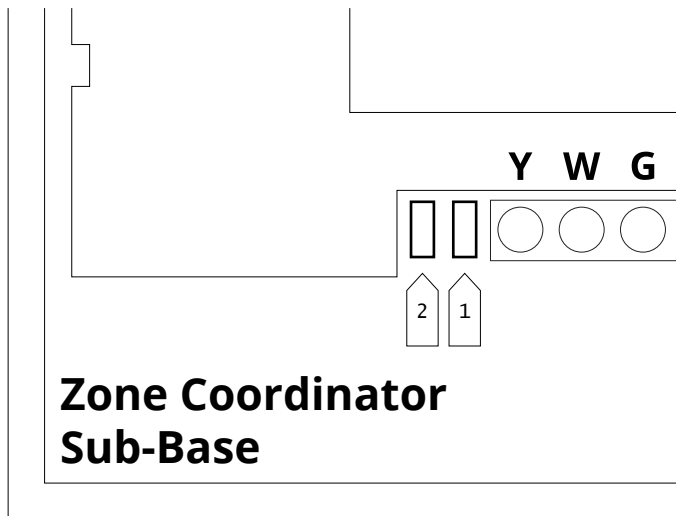

1 Internal Status Light:

LED State...	Meaning...	Troubleshoot...
OFF	No Power	Use a multi-meter and confirm there is 23 - 30V AC between the R & C terminals at the zone coordinator. Reference “Wiring - Power on page 15.
Fast Blink (every 1 sec)	Initializing	<p>If the zone coordinator does not complete this process, check that it is able to communicate with its Antenna, reference “Mounting and Wiring - Antenna” on page 13:</p> <p>Antenna installed inside zone coordinator:</p> <ul style="list-style-type: none"> Verify the three (3) pin connectors between the antenna and sub-base are properly seated and have a solid connection to each other. <p>Antenna installed separate of sub-base:</p> <ul style="list-style-type: none"> Verify the R, C, & D wires are making good connections at both the antenna and sub-base. The antenna might power ON if R & C are reversed, but communication will not establish. Check wires. Confirm there are no splices affecting the power and communication connections.
ON (solid green)	Operational	The zone coordinator’s antenna and sub-base are communicating on a reliable connection.

2 Wireless Status Light:

LED State...	Meaning...	Troubleshoot...
OFF	Waiting	Light will remain OFF until Internal Status LED [1] is solid green.
Fast Blink (every 1 sec)	Establishing Wireless Connection	<p>If the controller is unable to find a wireless network:</p> <p>Most Common Issue:</p> <ul style="list-style-type: none"> The antenna is installed in a location where it cannot reach the Pelican wireless network. Reference “Planning - Wireless Network: on pages 11 & 12 for wireless network planning. <p>Rare Issue:</p> <ul style="list-style-type: none"> It is connected to the network, but the Pelican gateway does not have an active Ethernet connection and therefore the zone coordinator cannot authenticate to the cloud server. Check the gateway.
ON (solid green)	Talking Over Wireless	The device is connected.

Start-Up: Antenna LED Light

The antenna needs to be wired to the sub-base using a 3-wire power and communication cable. Refer to “Mounting and Wiring - Antenna” on pages 13 & 14. The antenna has one LED light located to the right of the terminal blocks. This LED provides feedback on power and wireless connectivity.

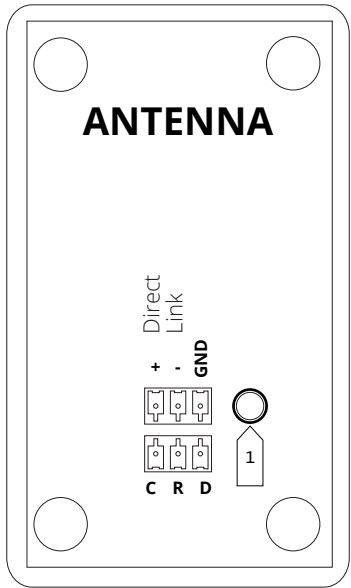

1 Antenna Wireless Status Light:

LED State...	Meaning...	Troubleshoot...
OFF	Waiting	No Power.

Fast Blink (every 1 sec)	Establishing Wireless Connection	If the controller is unable to find a wireless network:
-----------------------------	--	--

Most Common Issue:

- The antenna is installed in a location where it cannot reach the Pelican network. Reference “Planning - Wireless Network: on pages 11 & 12 for wireless network planning.

Rare Issue:

- It is connected to the network, but the Pelican gateway does not have an active Ethernet connection. Check the gateway.

Blink (every 15 sec)	Talking Over Wireless	The device is connected.
-------------------------	--------------------------	--------------------------

Setting Configurations

All configurations are set through the Pelican Connect app:

Step 1: Locate the zone coordinator’s Serial Number on the front of its Antenna.

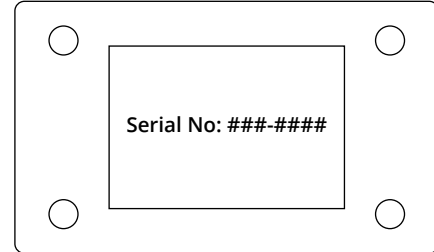

Step 2: Log into the Pelican Connect app. At the top under Notifications, there will be a selectable new Zone Controller with a matching serial number. If there is no notification, reference “Start-Up: Sub-Base LED Lights” on page 29. You can also check the Admin section of the app and see if under Zone Controllers there is a matching device serial number.



Step 3: In the zone coordinator’s configuration settings, enable and set the correct configurations based on the equipment the controller is wired to control. Reference “Configurations” on pages 31 to 36.

For device operations, reference “Sequence of Operations” on pages 37 to 47.

Final Step: If not already installed, install all the Pelican zone thermostats to control the zone dampers. Then link them to the zone coordinator. The zone coordinator will only operate its equipment if heating, cooling, or ventilation requests from zone thermostats are being sent.

IMPORTANT: NEVER wire any zone thermostat D terminals to the zone coordinator! This will create communication issues and the system will not operate.

Configurations

Zone coordinator configurations are set through the Pelican Connect app. For the zone coordinator to be configured, it must be connected to the Pelican wireless network and the network must have an active Pelican gateway.

Configurations must match the sequences for the equipment the controller is wired to. Reviewing each configuration is crucial for proper sequencing. Incorrect configurations can negatively impact the performance of the equipment.

The controller will not properly operate the HVAC equipment if the following conditions are true:

- The zone coordinator is not correctly wired to the equipment it is controlling.
- Temperature sensors are not installed correctly, are not properly wired to the zone coordinator, and are detecting inaccurate temperatures.
- The supply duct static pressure, ambient pressure probes, and tubes are not properly connected to the zone coordinator and are reading inaccurate pressures.
- All zone dampers and their associated reheats (if available) are not yet wired to and are not yet being controlled by Pelican zone thermostats.
- All zone thermostats have not been linked and are unable to communicate with the zone coordinator over the wireless network.
- There are equipment malfunctions or other mechanical issues that need to be fixed.

IMPORTANT

This section is for reference only. The zone coordinator regularly receives updates and additional configuration options that may not be included in this guide. For further assistance or help with specific application needs, contact Pelican engineering support.

Navigating to the Configurations:

1. Login to the Pelican Connect app.
2. Select Admin.
3. Select Zone Controllers.
4. Select the controller being configured.
5. Select Configuration Settings.

Table Key:

(D) = Default.
 (R) = Range.
 (advanced) = Advanced configurations are provided but with limited access.

Identification

Allows you to set a custom identifier and add notes for the zone coordinator, the HVAC equipment being controlled, and any other relevant information about the system.

Configuration Name/Description	Settings/Range
Name – Allows for a unique name to be assigned to the zone coordinator.	(D) (no name)
Description – Allows notes to be inputted for tracking information unique to this controller and/or the system this controller is wired to.	(D) (empty)

System Settings

Configurations for equipment type and number of stages the zone coordinator is controlling.

Configuration Name/Description	Settings/Range
System Type – Set to match the HVAC equipment being controller.	(D) Conventional Heat Pump
Heat Stages – Sets the number of heat stages.	(D) 2 (R) 0 to 3
Cool Stages – Sets the number of cool stages.	(D) 2 (R) 0 to 3
Reversing Valve (Heat Pump Only) – Sets when the reversing valve will be energized.	(D) Cooling On Heating On
Aux Heat¹ (Heat Pump Only) – Sets when the Auxiliary Heat will be use to supplement compressor heat.	(D) Disabled Auxiliary Emergency
Fan Stages – Sets the number of supply fans.	(D) 1 (R) 1 or 2
Heat Needs Fan (Conventional Only) – Sets if the controller needs to enable the supply fan during a central heating cycle.	(D) No Yes
Compressor OSA Lockout (advanced configuration) – Compressor is inhibited below this outside temperature.	(D) (blank) disabled (R) -20°F to 180°F

¹For information on how this configuration affects the Aux Heat configuration sequencing, reference the Heat Pump Operation sequence on Page 44.

Variable Speed Fan

When set to ON: analog output [A1] will be configured to modulate the fan speed using a 0–10V DC signal. 0V DC = 0% & 10V DC = 100% Fan Speed.

Configuration Name/Description	Settings/Range
Minimum Operating Speed – Sets the minimum output/speed when the supply fan is active.	(D) 20% (R) 0% to 100%

Configurations

Bypass Controller

When set to ON: analog output (A2) will be designated to modulate a bypass using a 0 or [2]-10V DC signal.

Configuration Name/Description	Settings/Range
Damper Voltages – Sets the volt [DC] range for modulating a bypass actuator: Open = 100% Bypass Air Closed = No Bypassed Air	Open: (D) 2.0V DC (R) 0.0 to 10.0 Closed: (D) 10.0V DC (R) 0.0 to 10.0

Static Pressure

Sets static pressure targets and reset limits, in inch of water columns.

Configuration Name/Description	Settings/Range
Target Operating Static – The static pressure target during a cooling, economizer, central heating, and reheat cycle. Configure so that when all zone dampers are at their maximum position they are at or above their maximum designed airflow.	(D) 0.75" W.C. (R) 0.0" to 8.0"
Target Heat Static (advanced configuration) – The static pressure target during a heating cycle.	(D) (not used) (R) 0.0" to 8.0"
Target Circulation Static¹ – The static pressure target during a fan/ventilation only cycle. Configure so that when all zone dampers are at their maximum positions they are at or above their minimum designed airflow.	(D) 0.50" W.C. (R) 0.0" to 8.0"
Minimum Static – The minimum reset static pressure anytime the fan is running. This is a fault detection configuration and should be set lower than the Target Operating and Target Circulation settings.	(D) 0.10" W.C. (R) 0.0" to 8.0"
Maximum Static – The maximum reset static pressure anytime the fan is running. This is a fault detection configuration and should be set at a reset point much higher than the Target Operating static.	(D) 1.50" W.C. (R) 0.0" to 8.0"

¹The Δ between the configured Target Circulation and the Target Operating Static will affect the outside damper position. For more information on how static pressure targets adjust ventilation rates, reference the Ventilation and Demand Ventilation sequence on Page 41.

Economizer

When set to ON: provides adjustments of the outside damper for economizer and ventilation sequences.

Configuration Name/Description	Settings/Range
High Limit Shut Off – Disables the economizer if the outside air temperature rises above this setting. Leave blank for AUTO ¹ .	(D) Auto (R) 0°F to 180°F
Activation Differential – Economizer is available if the outside temperature is at least this many degrees below the return temperature.	(D) 2°F (R) 0°F to 6°F
Fixed Enthalpy Limit – Enables outside enthalpy. Economizer will be disabled if outside enthalpy is above 28 BTU/lb.	(D) No Yes
Low Limit Temperature² (advanced configuration) – Sets the low limit mixed air temperature for an economizer cycle.	(D) 56°F (R) 0°F to 180°F
Exhaust Enable Damper Position (advanced configuration) – G2 will enable during economizer or demand ventilation if the outside damper is at or beyond this %.	(D) 0% (R) 0% to 100%
Variable Damper – Enables modulating control logic for the outside damper.	(D) Yes No
Damper Voltages – Sets the volt [DC] range for modulating the outside damper actuator.	Open: (D) 10.0V DC (R) 0.0 to 10.0 Closed: (D) 2.0V DC (R) 0.0 to 10.0
Minimum Damper Position – Sets a minimum ventilation rate.	(D) 10% (R) 0% to 100%
Track Damper Position³ – Enables Fault Detection and Diagnostics (FD&D) feedback.	(D) Yes No
Demand Ventilation³ – Enables demand ventilation sequences.	(D) On Off
Maximum Ventilation Position⁴ – Sets a maximum ventilation rate during demand ventilation.	(D) 100% (R) 0% to 100%

¹AUTO: the controller references the Δ between outside and return air to decide when an economizer sequence should be active.

²The supply temperature is used as a mixed air reading, unless a dedicated mixed air sensor is installed and configured.

³The outside damper ventilation position will increase in relation to the zone with the farthest CO₂ reading from its CO₂ set-point.

⁴Does not affect economizer sequences.

Configurations

Humidity Settings

When set to ON: provides dehumidification sequences. Additional dehumidification sequences are available which might not be documented in this operations manual. Contact Pelican Engineering Support for further assistance.

Configuration Name/Description	Settings/Range
Control Mode – Sets the dehumidification sequence.	(D) None Cool + Heat Cool + DH Cool + Reheat
Target Supply Temperature – Sets the target supply air temperature when modulating a reheat source.	(D) 70°F (R) 0°F to 180°F
Cool Stages – Sets how many mechanical cooling stages will be active during a dehumidification cycle.	(D) 1 (R) 1 to 3
Target Dehumidify Static – Sets the static pressure target, in inches of water columns, during a dehumidification cycle.	(D) Not Used (R) 0.0" to 8.0"

Boiler Controller

When set to ON: (W1) will be set as a hot water pump start/stop and (W2) will be set as a boiler start/stop.

Configuration Name/Description	Settings/Range
Operating Range – When the system needs heat, the pump and boiler will be enabled. This configuration identifies the temperature the boiler supply must reach before the heating cycle will be released to start and a high limit temperature for alarming.	(D) 100°F to 175°F (R) -22°F to 180°F

Power Consumption

Provides settings for the consumption of different stages. The number of inputs will adjust based on number of stages the zone coordinator is controlling.

Settings can be in different units:

BTU - British Thermal Units - most common for gas furnaces and hot water.

TON - Tonnage - most common for compressor stages and chilled water.

KW - Kilowatt - most accurate if true kilowatt consumption is known for each stage.

WATT - Watt - most accurate if true watt of consumption is known for each stage.

Configuration Name/Description	Settings/Range
Heat Size – Sets the size or energy load when the first stage of heating is enabled.	(D) (blank) (R) Variable input
Heat 2 Size – Sets the size or energy load when the second stage of heating is enabled.	(D) (blank) (R) Variable input
Heat 3 Size – Sets the size or energy load when the third stage of heating is enabled.	(D) (blank) (R) Variable input
Heat 4 Size – Sets the size or energy load when the fourth stage of heating is enabled.	(D) (blank) (R) Variable input
Heat 5 Size – Sets the size or energy load when the fifth stage of heating is enabled.	(D) (blank) (R) Variable input
Heat 6 Size – Sets the size or energy load when the sixth stage of heating is enabled.	(D) (blank) (R) Variable input
Cool Size – Sets the size or energy load when the first stage of cooling is enabled.	(D) (blank) (R) Variable input
Cool 2 Size – Sets the size or energy load when the second stage of cooling is enabled.	(D) (blank) (R) Variable input
Cool 3 Size – Sets the size or energy load when the third stage of cooling is enabled.	(D) (blank) (R) Variable input
Cool 4 Size – Sets the size or energy load when the fourth stage of cooling is enabled.	(D) (blank) (R) Variable input
Cool 5 Size – Sets the size or energy load when the fifth stage of cooling is enabled.	(D) (blank) (R) Variable input
Cool 6 Size – Sets the size or energy load when the sixth stage of cooling is enabled.	(D) (blank) (R) Variable input

Input Configurations

IMPORTANT

This section goes over the T1, T2, & T3 configurations. For analog inputs, S1 & S2, they are auto-configured to match which output is being used to controller the outside damper. For example, if A2 is used for the outside damper then S2 will be used as the outside damper position feedback for Fault Detection and Diagnostics (FD&D).

Temperature Configuration Definitions:

Supply Temperature – Used as the temperature reading when targeting a heating or cooling discharge temperature. This can also act as the low limit mixed air temperature reading during economizer cycles.

Return Temperature – Used as the temperature reading to calculate a differential heating and cooling discharge target and to decide if an economizer cycle should be active.

Outside Temperature – Used as the temperature reading when calculating when an economizer cycle should be active, what damper position the outside damper should start at to prevent a low limit mixed air temperature, and for compressor lockout.

Boiler Temperature – Used as the temperature reading in relation to the boiler enable sequence.

Heat Supply Temperature – Used for mixing box applications to differentiate the heating supply temperature from the cooling supply temperature.

When an input is set for Heat Supply Temperature, then the input set as Supply Temperature will be used as the cooling supply temperature.

Mixed Air Temperature – Used in applications where a temperature reading is needed in the mixed air section to increase response rate when preventing economizer low limit mixed air temperatures.

This should be used instead of a return temperature for applications in environments where extremely low outside air temperatures might occur.

Alarm – When an input is set for Alarm, it becomes a dry-contact input. Additional configurations become available to define when this alarm is active:

- **Always** - If the dry-contact changes states, a notification will be generated.
- **During: Heating** - If the dry-contact is not in the correct state during a heating cycle, a notification will be generated.
- **During: Cooling** - If the dry-contact is not in the correct state during a cooling cycle, a notification will be generated.

- **During: Fan** - If the dry-contact is not in the correct state during a fan active cycle, a notification will be generated.

Temp Monitor – When an input is set to Temp Monitoring, this input receives its own custom label and its own graphics for viewing real-time and historical temperature readings.

Input Sensor T1

When set to ON, this input can be set to any of the following:

Configuration	Settings
Function – Sets what function this input will be used for.	(D) Supply Temperature Return Temperature Outside Temperature Boiler Temperature Heat Supply Temperature Mixed Air Temperature Alarm Temp Monitor

Input Sensor T2

When set to ON, this input can be set to any of the following:

Configuration	Settings
Function – Sets what function this input will be used for.	(D) Supply Temperature Return Temperature Outside Temperature Boiler Temperature Heat Supply Temperature Mixed Air Temperature Alarm Temp Monitor

Input Sensor T3

When set to ON, this input can be set to any of the following:

Configuration	Settings
Function – Sets what function this input will be used for.	(D) Supply Temperature Return Temperature Outside Temperature Boiler Temperature Heat Supply Temperature Mixed Air Temperature Alarm Temp Monitor

Wired Sensor

Only available if a Pelican TA1 is wired to the controller as a fourth input:

Configuration	Settings
Function – Sets what function this input will be used for.	(D) Supply Temperature Return Temperature Outside Temperature Boiler Temperature Heat Supply Temperature Mixed Air Temperature Alarm Temp Monitor

Advanced Configurations

Advanced configurations have limited access. For assistance with advanced configurations, please contact Pelican engineering support.

IMPORTANT

This section is for reference only. The zone coordinator regularly receives updates and additional configuration options that may not be included in this guide. For further assistance or help with specific application needs, contact Pelican engineering support.

Advanced Settings

Provides adjustment of staging strategies and different operation limitations.

Configuration Name/Description	Settings/Range
Staging Strategy – Sets the target supply strategy.	(D) Differential Absolute
Differential¹ Target Supply Configurations:	
Moderate Cool Differential – Sets the moderate (min) cool target differential supply temperature.	(D) 10°F (R) -22°F to 180°F
Aggressive Cool Differential – Sets the aggressive (max) cool target differential supply temperature.	(D) 20°F (R) -22°F to 180°F
Moderate Heat Differential – Sets the moderate (min) heat differential target supply temperature.	(D) 30°F (R) -22°F to 180°F
Aggressive Heat Differential – Sets the aggressive (max) heat differential target supply temperature.	(D) 40°F (R) -22°F to 180°F
Absolute Target Supply Configurations:	
Moderate Cool Target – Sets the moderate (min) absolute cool target supply temperature.	(D) 55°F (R) -22°F to 180°F
Aggressive Cool Target – Sets the aggressive (max) absolute cool target supply temperature.	(D) 55°F (R) -22°F to 180°F
Moderate Heat Target – Sets the moderate (min) heat absolute target supply temperature.	(D) 105°F (R) -22°F to 180°F
Aggressive Heat Target – Sets the aggressive (max) heat absolute target supply temperature.	(D) 115°F (R) -22°F to 180°F
Minimum Supply Temp² – Sets the lowest supply temperature during a cooling cycle.	(D) 48°F (R) -22°F to 180°F

Advanced Configurations

Advanced Settings continued...

Configuration Name/Description	Settings/Range
Maximum Supply Temp³ – Sets the highest supply temperature during a heating cycle.	(D) 130°F (R) -22°F to 180°F
Use Priority Cooling – Sets zone cooling demand as priority.	(D) No Yes
Allow Zero Heat Stages – Allows the controller to stage down to zero (0) heat stages during a central heating cycle. Commonly used in bypass applications and high output 1st stage heating systems.	(D) No Yes
Minimum Heating Capacity* – Sets the minimum capacity % required to start a central heating cycle.	(D) 0% (R) 0% to 100%
Minimum Cooling Capacity* – Sets the minimum capacity % required to start a cooling cycle.	(D) 0% (R) 0% to 100%
Minimum Fan Capacity* – Sets the minimum capacity % required to enable the supply fan.	(D) 0% (R) 0% to 100%

¹Δ between the supply and return temperatures.

²During a cooling cycle, if the discharge air temperature gets within 5°F of this temperature, the controller will stage down the number of active cooling stages and/or reset the modulating output to try and keep the discharge temperature from exceeding this low limit. The controller will stage down to [0] zero cool stages if needed.

³During a heating cycles, if the discharge air temperature gets to this temperature, the controller will alarm and shut down heating. The controller will only stage to [0] zero heat stages if the configuration Allow Zero Heat Stages is set to Yes.

*Reference the Sequence of Operation Capacity Management on page 44 for more information.

Advanced Configurations

Variable Temperature Settings

Provides adjustment to the modulation strategies and which analog outputs are assigned to which modulation sequence.

Configuration Name/Description	Settings/Range
Type – sets what modulating sources are available to the controller.	(D) None Heat Cool Heat & Cool
Modulating Heat Configurations:	
Heat Signal Output – sets which analog output is used for heat modulation. Only unassigned outputs are available.	(D) A4 A1 A2 A3 Float (W2, W3)
Heat Actuator Voltages – Sets the volt [DC] range for the modulating heating source: Open = Max Heating Closed = No Heating	Open: (D) 10.0V DC (R) 0.0 to 10.0 Closed: (D) 2.0V DC (R) 0.0 to 10.0
Floating Heat Configurations:	
Heat Actuator Travel Time – Sets the number of seconds for the heating source to rotate from no heating to max heating.	(D) (blank) (R) 1 to 400 seconds
Additional Variable Heat Configurations:	
Heat Always Active – the controller will continuously modulate its heating source to maintain the moderate heating target.	(D) No Yes
Control Staging¹ – Links the staging algorithm to the modulating heat algorithm.	(D) No Yes
Temper Air² – the controller will temper the supply duct.	(D) No Heat Duct if Cooling ² During Ventilation
Initial Heat Actuator Position – sets the starting volt DC output when a heating cycle begins.	(D) 30% (R) 0% to 100%
Change Heat Actuator Delay Minutes – sets an interval timer for when the next calculated modulation adjustment is made.	(D) 1 minute (R) 1 to 10 minutes

Modulating Cool Type Configurations:	
Configuration Name/Description	Settings/Range
Cool Signal Output – sets which analog output is used for cool modulation. Only unassigned outputs are available.	(D) A3 A1 A2 A4 Float (Y2, Y3)
Cool Actuator Voltages – Sets the volt [DC] range for the modulating heating source: Open = Max Cooling Closed = No Cooling	Open: (D) 10.0V DC (R) 0.0 to 10.0 Closed: (D) 2.0V DC (R) 0.0 to 10.0
Float Cool Type Configurations:	
Cool Actuator Travel Time – Sets the number of seconds for the cooling source to rotate from no cooling to max cooling.	(D) (blank) (R) 1 to 400 seconds
Variable Cool Configurations:	
Cool Always Active – the controller will continuously modulate its cooling source to maintain the moderate cooling target.	(D) No Yes
Control Staging¹ – Links the staging algorithm to the modulating cool algorithm.	(D) No Yes
Initial Cool Actuator Position – sets the starting volt DC output when a cooling cycle begins.	(D) 30% (R) 0% to 100%
Change Cool Actuator Delay Minutes – sets an interval timer for when the next calculated modulation adjustment is made.	(D) 1 minute (R) 1 to 10 minutes

¹When set to Yes, the next stage will not be enabled until the modulating source is at 100%. Then, when the next stage is enabled, the modulating source will adjust down proportionally to retain the same output load. Reference "Sequence of Operation - Variable Temperature Linked to Staging" on page 46.

²Heat Duct if Cooling is commonly used in Mixing Box applications where the outside damper is ducted to both the hot and cold decks.

Sequence of Operations

The zone coordinator supports various types of configurations which affect sequences, including:

- Standard heat/cool unit types with up to six stages of mechanical cooling and/or gas or electric heating.
- Heat pump units with up to six stages of compressor, utilizing a reversing valve output for heating and cooling control, and a secondary auxiliary heating source.
- Variable heat/cool units with a modulating compressor, gas furnace, and/or hot water or chilled water valves.
- Economizer, Minimum Ventilation, Demand Ventilation, Low Limit Compressor Lockout, and Enthalpy sequences.
- Variable speed fan, bypass damper, inlet vane, or other modulation controls with static pressure reset sequences. Static pressure low and high limit resets.
- Mixed air low limit temperatures, minimum and maximum temperature resets, and supply temperature reset sequences.
- Optimum Start adaptive algorithm.
- Minimum capacity limiting sequences.
- Dedicated hot water pump and boiler enable/disable.

For sequences that are outside of this document, contact Pelican support for further assistance.

Occupancy

The zone coordinator's occupancy is linked to zone thermostat requests. It does not operate independently. An "occupied" period for a zone coordinator occurs anytime a zone thermostat sends a request over the Pelican wireless mesh network.

A zone thermostat's demand may include:

- **Cooling Cycle Request:** Indicates the amount of cooling required for the zone.
- **Heating Cycle Request:** Indicates the amount of heating required for the zone.
- **Ventilation or Demand Ventilation Cycle Request:** Can include minimum ventilation requirements or CO2 readings..
- **Dehumidification Cycle Request:** Indicates the need for dehumidification.

The Pelican Connect app provides a real-time and scheduled dashboard for managing thermostat settings.

Users can set zone-level Occupied/Unoccupied periods, event periods, and/or vacation periods.

Thermostats can also be manually enabled through the app or directly at the thermostats installed inside the building, if allowed.

Supply Fan

The zone coordinator can be configured for either Constant Speed or Variable Speed supply fan control:

- **Constant Speed:** The fan will operate in an on/off manner.
- **Variable Speed:** The fan will adjust to different speeds to maintain a target supply duct static pressure.

The zone coordinator's fan operation is dependent on receiving a Demand from a Pelican zone thermostat.

The supply fan will be activate during these Demands:

- A request for a cooling cycle.
- A request for a heating cycle (if configured).
- A request for a fan/ventilation cycle.
- A request for a reheat cycle (except parallel and series boxes).
- A request for a dehumidification cycle.

Static Pressure Targets

The zone coordinator must be wired to control either a bypass or a variable speed supply fan. The Static Pressure target is maintained by controlling these systems as follows:

- **Bypass Damper:** The fan operates in an on/off mode, and the bypass damper modulates to maintain the target static pressure.
- **Variable Speed:** The fan enables/disables and modulates to different speeds to maintain the target supply duct static pressure. A configurable Minimum Fan Speed is enforced.

The zone coordinator provides multiple static pressure target configurations:

- **Target Operating Static:** This will be the active target during a cooling, heating, zone reheat, and economizer cycle.
- **Target Circulation Static:** This target will be active during a fan only, ventilation, or demand ventilation cycle.
- **Target Heat Static (advanced):** Allows for a different static target during a central heating or reheat cycle.

Sequence of Operations

- **Target Dehumidification Static:** Allows for a different static target during dehumidification cycles.

Alarms:

Below Minimum Static Alarm: Triggered if the supply fan is enabled but the static pressure does not reach the configured Minimum Static setting. Cooling and heating will be disabled, initiating an automatic 10-minute reset cycle.

Above Maximum Static Alarm: Triggered if the supply fan is enabled and the static pressure exceeds the configured Maximum Static setting. Cooling and heating will be disabled, initiating an automatic 10-minute reset cycle.

Mechanical Cooling

When the zone coordinator is wired to start/stop when mechanical cooling is active, the controller's configurations determine the mechanical cooling sequences the zone coordinator will follow:

- **Cooling Stages:** The zone coordinator can control up to six stages of mechanical cooling, with an additional output for a reversing valve for heat pump applications.
- **Modulation Options:** It can modulate a direct-expansion (DX) compressor or a chilled water valve and can also be configured to modulate, float, or open/close a chilled water valve position.

The following conditions must be met for the mechanical cooling sequence to operate correctly:

- **Valid Temperature Readings:** The zone coordinator must have valid readings from the Supply Temperature, Outside Air Temperature, and Return Temperature sensors.
- **Outside Air Temperature:** The Outside Air Temperature must be above the configured Low Limit Outside Air Compressor Lockout, if being used.
- **Economization:** Economization must be unavailable, or if active, it must be unable to maintain the target supply temperature on its own.
- **Cooling Demand:** The zone coordinator must receive Cooling Demand requests from one or more zone thermostats.
- **Capacity Management:** The minimum number of zones must be in cooling demand and able to provide sufficient airflow during a cooling cycle, if being used.

- **Heating Cycle:** There must be no active Heating or Reheat Cycle, and the last heating cycle must have been off long enough to purge excess hot air from the HVAC equipment.

- **No Alarms:** No Static Pressure resets or alarms should be active.

Mechanical cooling staging and modulation are managed by the Cooling Target PID loop and Cooling Demand Level algorithms. These algorithms determine the number of stages and modulation positions needed to reach the target supply temperature.

Activation: Once the mechanical cooling preconditions are met, mechanical cooling will be enabled and staged or modulated to maintain the target supply temperature. Four-minute anti-short cycling timers are used to protect mechanical equipment.

Modulation: The zone coordinator may reduce the number of active stages or modulation output if the supply temperature falls below the target or approaches the Minimum Supply Temperature limit. If the supply temperature rises above its target, stages will restart after the anti-short cycling timer expires, or modulation will increase to recapture the target supply temperature.

During an active cooling cycle, the Cooling Demand Level algorithm calculates the necessary Target Supply Temperature to condition the building. This calculation adjusts based on the cooling demand from zone thermostats.

Cycle Communication: Initially, when a cooling cycle is about to start, the zone coordinator will notify zone thermostats. The thermostats will confirm back to the zone coordinator, indicating they have adjusted their dampers in anticipation of the cooling cycle.

Static Control: The zone coordinator will set its bypass damper to 100% bypass (if installed) and enable the supply fan. If a variable speed fan is installed, it will operate at the configured Minimum Operating Speed or 50% speed, depending on the last run fan speed and current static pressure reading vs. target. The bypass damper will adjust to reduce bypassed air, or the supply fan speed will increase to maintain the Target Operating Static.

Mechanical cooling will continue as long as static pressure readings are within configured limits and all preconditions are met. Cooling will be disabled when all cooling demands are satisfied, a precondition is no longer met, or a change-over cycle is calculated to start. An automated reset will attempt to re-enable cooling if demands persist and preconditions are restored.

Sequence of Operations

Economizer

When the zone coordinator is wired to modulate an outside damper using an analog 0[2] – 10 V DC signal, the controller's economizer configurations determine the specific economizer sequences the zone coordinator will follow. An economizer cycle is used to provide free cooling when outside air conditions are suitable to assist in conditioning the building.

The following conditions must be met for an economizer cycle to start:

- **Valid Temperature Readings:** The zone coordinator must have valid readings from the Supply Temperature, Return Temperature, and Outside Air Temperature sensors.
- **Activation Differential:** The Outside Air Temperature must be less than the configured Activation Differential from the return air temperature and below the configured outside air High Limit Shut Off¹.
- **Enthalpy Limit:** The outdoor Enthalpy must be below 28 btu/lb if the Fixed Enthalpy Limit configuration is set to YES.
- **Cooling Demand:** The zone coordinator must receive Cooling Demand requests from one or more zone thermostats.
- **Capacity Management:** The minimum number of zones must be in cooling demand or able to provide airflow into their zones during a cooling cycle, if being used.
- **Heating Cycle:** There must be no active Heating or Reheat Cycle, and the last heating cycle must have been off long enough to purge excess heat from the HVAC equipment.
- **No Alarms:** No Static Pressure resets or alarms should be active.

When these preconditions are met, the zone coordinator uses its Cooling Demand Level algorithm to calculate the needed Target Supply Temperature to condition the building. This algorithm adjusts the target supply temperature based on the cooling demand from zone thermostats, ensuring the central air handler operates in response to real-time building demand.

Cycle Communication: Initially, when an economizer cycle is about to begin, the zone coordinator will notify zone thermostats. Zone thermostats will confirm back to the zone coordinator, indicating they have received the notification and adjusted their dampers in anticipation of the cooling cycle.

¹If the High Limit Shut Off is set to AUTO, the zone coordinator will use its own internal calculation to decide if the outside air is too warm to be suitable for use during an economizer cycle.

Static Control: The zone coordinator will set its bypass damper to 100% bypass (if installed) and then enable the supply fan. If a variable speed fan is installed, it will operate at the configured Minimum Operating Speed. The bypass damper will adjust to reduce bypassed air, or the supply fan speed will increase to maintain the Target Operating Static.

The economizer sequence will start as long as the static pressure reading is within configured limits and all preconditions are met. The zone coordinator may also enable its Auxiliary Output (G2) as referenced in the Power Exhaust or Recovery Wheel Sequence of Operation on page 43.

Damper Position: The zone coordinator's Economizer Position PID loop will calculate an initial outside damper position based on its outside air temperature reading and the configured Low Limit Temperature¹. The outside damper will open to this calculated position or 100% open, whichever is less. The Economizer Position PID loop may adjust the damper position to prevent the supply temperature from falling below the configured Low Limit Temperature¹.

If the supply temperature cannot be maintained at the target, the zone coordinator's Cooling Target PID loop will enable and stage or modulate mechanical cooling to maintain the target supply temperature. The Economizer Position PID loop may further adjust the damper position as needed. The economizer sequence will remain active until all zone thermostat cooling demands are satisfied, or a precondition is no longer met. Depending on the precondition, an automated reset will attempt to re-enable the economizer if cooling demand persists and preconditions are restored.

Economizer Fault Detection & Diagnostics (FD&D)

The zone coordinator provides FD&D (Fault Detection & Diagnostics) for all outside damper sequences and meets California Title 24.

The FD&D detects and alarms at the Pelican Connect app the following outside damper faults:

- Air temperature sensor failure/fault.
- Not economizer when it should.
- Economizing when it should not.
- Damper not modulating.
- Excess outdoor air.

¹Low Limit Temperature defaults to the mixed air reading from the Supply Temperature Probe. For extreme weather applications, the Low Limit Temperature can be linked to a Mixed Air Sensor mounted in the mixed air section of the economizer assembly. Using a Mixed Air Sensor can generate faster economizer reactions during periods of extremely low ambient temperatures.

Sequence of Operations

The FDD provides the following real-time and historical system statuses at the Pelican Connect app:

- Free cooling available.
- Economizer enabled.
- Compressor enabled.
- Heating enabled, if the system is capable of heating.
- Mixed air low limit cycle active.
- The value of each sensor.

The following conditions must be met to enable FD&D (Fault Detection & Diagnostics):

- **Damper Actuator Feedback:** The outside damper actuator must be wired to provide a feedback position to the zone coordinator.
- **Configuration Setting:** The Track Damper Position configuration must be set to YES.

Power Exhaust and/or Recovery Wheel

If the zone coordinator is wired to enable or disable a power exhaust fan, an energy recovery wheel (ERV), and/or a heat recovery wheel (HRV) during an economizer or demand ventilation sequence, the controller's configurations will determine the specific sequences the zone coordinator will follow.

To interlock any of these systems with the supply fan, use the supply fan (G) output from the zone coordinator to start the systems together.

If these systems need to be controlled based on the zone coordinator being in an Economizer or Demand Ventilation Cycle and the outside damper position exceeding a specific percentage open, use the auxiliary (G2) output from the zone coordinator to start or stop the external system.

The following conditions must be met for the (G2) output to be active:

- The zone coordinator is in an active Economizer or Demand Ventilation cycle.
- The outside damper is open beyond the configured Exhaust Enable Damper Position (default 0%), if applicable.

Central Heating (Morning Warm-Up)

If the zone coordinator is wired to start/stop when central heating is active, the controller's configurations determine the specific heating sequences the zone coordinator will follow:

- **Heat Stages:** The zone coordinator can control up to six stages of heat, with additional outputs for a reversing valve and auxiliary heat (for heat pump applications).
- **Modulation Options:** It can modulate a furnace's gas valve or a hot water valve and can also be configured to operate a hot water valve in either floating or two-position mode.

The following conditions must be met for the central heating sequence to operate correctly:

- **Valid Temperature Readings:** The zone coordinator must have valid readings from the Supply Temperature, Outside Air Temperature, and Return Temperature sensors.
- **Outside Air Temperature:** The Outside Air Temperature must be above the low limit outside air Compressor Lockout (applicable for heat pump configurations).
- **Heating Demand:** The zone coordinator must receive Heating Demand requests from one or more zone thermostats. If zone thermostats have local reheats, the Heating Demand requests must indicate a need for a central heating cycle.
- **Capacity Management:** The minimum number of zones must be in heating demand or able to provide sufficient airflow during a heating cycle.
- **Cooling Cycle:** There must be no active Cooling or Economizer Cycle, and the last cooling cycle must have been off long enough to purge excess cold air from the HVAC equipment.
- **No Alarms:** No Static Pressure alarms should be active.

Heating staging and modulation are managed by the Heating Target PID loop and Heating Demand Level algorithms. These algorithms determine the number of stages and modulation positions needed to reach the target supply temperature.

Activation: When heating preconditions are met, central heating will be enabled and staged or modulated to maintain the target supply temperature. Anti-short cycling timers are used to protect mechanical equipment.

Modulation: The zone coordinator may reduce the number of active stages or modulation output if the

Sequence of Operations

supply temperature exceeds the target or approaches the Maximum Supply Temperature limit. If the supply temperature drops below the target, stages will restart after the short-cycling timer expires, or modulation will increase to recapture the target supply temperature.

During an active heating cycle, the Heating Demand Level algorithm calculates the necessary Target Supply Temperature to condition the building. This calculation adjusts based on real-time building demand.

Cycle Communication: When a heating cycle is about to start, the zone coordinator will notify zone thermostats. The thermostats will send confirmations back to the zone coordinator, indicating they have adjusted their dampers in anticipation of the heating cycle.

Static Control: The zone coordinator will set its bypass damper to 100% bypass (if installed) and enable the supply fan. If a variable speed fan is installed, it will operate at the configured Minimum Operating Speed. The bypass damper will adjust to reduce bypassed air, or the supply fan speed will increase to maintain the Target Operating Static¹.

Heating will continue as long as static pressure readings are within configured limits and all preconditions are met. Heating will be disabled when all heating demands are satisfied, a precondition is no longer met, or a change-over cycle occurs. An automated reset will attempt to re-enable heating if demands persist and preconditions are restored.

Heat Tempering

The zone coordinator can temper the supply air under three conditions:

- **Mixing Box:** The HVAC equipment and mechanical design is a Mixing Box, and during an economizer sequence, you need to temper the hot deck.
- **Ventilation:** During Ventilation, the system needs to maintain a minimum supply temperature.
- **Dehumidification:** During a Dehumidification cycle (reference page 48 for sequencing of operation).

The following conditions must be met for heat tempering to start for a Mixing Box application:

- **Valid Temperature Readings:** The zone coordinator must have valid Cold Deck Supply Temperature, Hot Deck Supply Temperature, Outside Air Temperature, and Return Temperature sensors.
- **Cooling Demand:** The zone coordinator must receive Cooling Demand requests from one or more zone thermostats and either a Cooling or Economizer cycle is active.

- **Configuration Setting:** The Temper Air During Cooling configuration must be enabled, the zone coordinator is configured for Variable Temperature Control, and the current Hot Deck Supply Temperature reading is below the minimum hot deck supply configuration.
- **No Alarms:** No Static Pressure alarms should be active.

When heat tempering preconditions are met, the Temper Target PID loop will modulate a central heating source to maintain a minimum hot deck supply temperature of 75°F.

The following conditions must be met for heat tempering to start during a Ventilation application:

- **Valid Temperature Readings:** The zone coordinator must have valid Supply Temperature, Outside Air Temperature, and Return Temperature sensors.
- **Fan/Ventilation Demand:** The zone coordinator must receive Fan Demand requests from one or more zone thermostats and either a Cooling or Economizer cycle is active.
- **Cooling Cycle:** There must be no active Cooling or Economizer Cycle, and the last cooling cycle must have been off long enough to purge excess cold air from the HVAC equipment.
- **Configuration Setting:** The Temper Air During Ventilation configuration must be enabled, the zone coordinator is configured for Variable Temperature Control, and the current Supply Temperature reading is below the minimum supply configuration.
- **No Alarms:** No Static Pressure alarms should be active.

When heat tempering preconditions are met, the Temper Target PID loop will modulate a central heating source to maintain a minimum supply temperature of 68°F.

Ventilation and Demand Ventilation

If the zone coordinator is wired to modulate an outside damper using an analog 0[2] – 10 V DC signal, the controller's ventilation configurations determine the specific ventilation sequences the zone coordinator will follow. A ventilation cycle is used to provide outside air into the building to improve indoor air quality.

The following conditions must be met for a ventilation cycle to start:

¹If a Target Heat Static is configured, the sequence will maintain this static set-point, otherwise the Default target is the Target Operating Static.

Sequence of Operations

- **Valid Temperature Readings:** The zone coordinator must have valid readings from the Supply Temperature, Outside Air Temperature, and Return Temperature sensors.
- **Fan/Ventilation Demand:** The zone coordinator is getting Fan/Ventilation, Cooling, or Heating Demand requests from one or more zone thermostats.
- **Do Not Ventilate:** Zone thermostats are not sending a Do Not Ventilate message during unoccupied periods where ventilation is not required or during emergency periods such as Shelter-In-Place.
- **No Alarms:** No Static Pressure alarms should be active.

When ventilation preconditions have been met, and if the static pressure is being maintained at the Target Operating Static pressure, the zone coordinator will open the outside damper to its configured Minimum Damper Position to mix outside air with the building's return air. If the static pressure is being maintained at the Target Circulation Static pressure, the outside damper will modulate open beyond the Minimum Damper Position configuration, as calculated by the Ventilation Retention algorithm. This ventilation retention algorithm automatically adjusts the minimum outside ventilation rates proportional to the difference between the Operating and Circulating static pressure targets.

When a ventilation cycle is about to begin, the zone coordinator will communicate to zone thermostats that a ventilation cycle is going to start. Zone thermostats send confirmations back to the zone coordinator that they have received and adjusted their dampers in anticipation of the ventilation cycle.

The zone coordinator will set its bypass damper to 100% bypass, if installed, and then enable the supply fan. If a variable speed fan is installed, it will be set to run at the configured Minimum Operating Speed. The bypass will be rotated to reduce the amount of bypassed air OR the supply fan's speed will be increased to run above its minimum operating speed to maintain either the configured Target Operating Static, if an active heating, reheat, or cooling cycle is occurring OR the Target Circulation Static, if the ventilation cycle is the only active cycle. As long as the static pressure reading is above the configured Minimum Static and below the configured Maximum Static, and all preconditions have been met, the ventilation sequence will start.

The zone coordinator may reduce the outside air damper position to prevent the mixed air temperature from going below the configured Low Limit Temperature OR if it has determined that ventilation rates need to be temporarily reduced to achieve proper supply temp

Demand Ventilation (CO2)

To increase energy efficiency and indoor air quality, the zone coordinator can use a demand ventilation sequence which is interlocked in-room CO2 readings to the ventilation rates.

The following conditions must be met for a demand ventilation cycle to start:

- **Ventilation Preconditions:** All Ventilation preconditions are met.
- **Demand Ventilation Requests:** The zone coordinator is getting one or more Demand Ventilation requests from zone thermostats.

When demand ventilation preconditions have been met, the zone coordinator will modulate open the outside damper beyond the configured Minimum Damper Position to increase the amount of outside air being mixed with the building's return air.

The zone coordinator uses its Demand Ventilation PID loop to calculate how much the outside air damper should open beyond the configured Minimum Damper Position. This sequence is directly correlated to zone thermostat(s) sending a Demand Ventilation request and the zone with the greatest CO2 reading taking priority. The amount to which the outside damper will open is based on how far above 800 PPM the greatest CO2 reading is without exceeding the Maximum Ventilation Position configuration. When zone thermostat CO2 readings are below their configured Demand Ventilation settings and all ventilation preconditions have been met, the zone coordinator will provide ventilation at the configured Minimum Damper Position.

Outside Damper Fault Detection & Diagnostics (FD&D)

The zone coordinator provides FD&D (Fault Detection & Diagnostics) for all outside damper sequences and meets California Title 24.

The FD&D detects and alarms at the Pelican Connect app the following outside damper faults:

- Air temperature sensor failure/fault.
- Not economizer when it should.
- Economizing when it should not.
- Damper not modulating.
- Excess outdoor air.
-

The FD&D provides the following real-time and historical system statuses at the Pelican Connect app:

- Free cooling available.
- Economizer enabled.
- Compressor enabled.

Sequence of Operations

- Heating enabled, if the system is capable of heating.
- Mixed air low limit cycle active.
- The value of each sensor.

The following must be true to enable FD&D:

- **Damper Actuator Feedback:** The outside damper actuator must be wired to provide a feedback position to the zone coordinator.
- **Configuration Setting:** The Track Damper Position configuration must be set to YES.

Pre-Occupancy Ventilation

A pre-occupancy ventilation cycle allows the zone coordinator to use outside air to purge contaminants out of the building prior to the building becoming occupied. This sequence is identical to the Ventilation and Demand Ventilation sequences found on page 45.

For a pre-occupancy ventilation cycle to occur:

Ventilation Schedule: Zone thermostats should be scheduled to request a ventilation/fan cycle at least 1 to 2 hours before the normal building's occupancy schedule, and Outside Ventilation should be scheduled On.

Optimum Start

The zone coordinator's operation relies on its Pelican zone thermostats sending Demands. The zone coordinator does not operate on its own; it is 100% linked to zone thermostat requests, which are communicated to the zone coordinator over the Pelican wireless network.

To enable Optimum Start, zone thermostat schedules should be set to have Optimum Start active.

Optimum Start Algorithm: Zone thermostats with Optimum Start schedules enabled will use an Adaptive Learning Algorithm to calculate and adjust when they should request cooling or heating to bring their zone to an occupied set point by the time the schedule begins. The Optimum Start enable period may begin as early as 12:01 AM on the same day, but is traditionally started much closer to the scheduled occupied time.

The algorithm works by having each zone thermostat, each day, analyze its last seven (7) days of heating and cooling trend data to calculate how long it takes to precondition the zone and correlate these trend rates to the current room temperature to calculate a start time. Because each zone thermostat is doing its own calculations, the overall efficiency of when the zone coordinator will start a cooling or heating cycle to precondition the building is greatly enhanced.

Standard Sequences: The zone coordinator will follow the standard heating and cooling sequences as Optimum Start periods begin. This algorithm incorporates using outside air (economizer free cooling) to pre-cool the building, when available.

VAV Reheat

A VAV Reheat cycle is available to zone thermostats configured to control a local Reheat source (hot water, electric, etc.).

The following conditions must be met for a zone reheat cycle to start:

- **Valid Temperature Readings:** The zone coordinator must have valid readings from the Supply Temperature, Outside Air Temperature, and Return Temperature sensors.
- **Reheat Demand:** The zone coordinator must receive Reheat Demand requests from one or more zone thermostats.
- **Cooling Cycle¹:** There must be no active Cooling or Economizer Cycle, and the last cooling cycle must have been off long enough to purge excess cold air from the HVAC equipment.
- **No Alarms:** No Static Pressure alarms should be active.

When reheat preconditions are met, the zone coordinator will release zones to start their reheat cycle. Zone thermostats in reheat demand will enable and/or modulate, as applicable, their reheat to heat and/or maintain the target supply air temperature going into their zones.

The zone coordinator may enable a central heating cycle if the heating requests are great enough to calculate that a central heating cycle is more efficient than keeping the reheats active on their own, or if the reheats alone are unable to heat their zones.

When a reheat cycle is about to begin, the zone coordinator will communicate to zone thermostats that a reheat cycle is starting. Zone thermostats will confirm back to the zone coordinator that they have received the notification and adjusted their dampers in anticipation of the reheat cycle.

The zone coordinator will set its bypass damper to 100% bypass, if installed, and then enable the supply fan. If a variable speed fan is installed, it will be set to run at the configured Minimum Operating Speed. The bypass will be adjusted to reduce the amount of bypassed air, or the supply fan's speed will be increased to maintain the

¹If Allow Heating When Cooling is enabled for a zone thermostat, a VAV Reheat Cycle will be allowed to start even though there is an active Mechanical Cooling or Economizer Cycle.

Sequence of Operations

configured Target Operating Static. As long as the static pressure reading is above the configured Minimum Static and below the configured Maximum Static, and all preconditions are met, reheat will be enabled.

This will remain true until all zone thermostat reheat demands are eliminated, one of the preconditions is no longer met, or a change-over cycle occurs. Depending on the precondition, an automated reset will occur to try and enable reheating again if zone thermostat reheat demand still exists and the preconditions are again met.

Parallel Fan Powered Boxes with Reheats: Zone thermostats configured to control Parallel Fan Powered boxes will be allowed to start their local reheat cycles without having to meet the reheat preconditions listed in the VAV Reheat sequence.

Heat Pump Operation

If the zone coordinator is configured to control a heat pump's compressor stages, reversing valve, and an auxiliary heating source, the following conditions and configurations will apply:

Reversing Valve Control:

The W signal provides a 24V AC output to control the reversing valve.

The reversing valve may be configured to be energized when Cooling is ON (O) or when Heating is ON (b).

Staging and Modulating Sequences:

Same as described in the Cooling and Central Heating sequences, except the Y, Y2, & Y3 outputs enable the compressors, the W output enables the reversing valve, and W2 is used to enable Auxiliary Heat¹.

To prevent excessive reversing valve rotation, if the zone coordinator enters a cycle requiring the reversing valve, it will keep the reversing valve enabled until the opposite cycle occurs.

Equipment Control Configuration Options:

Select the Heat Pump configuration for traditional heat pump control and leave as Conventional for controlling heat pump equipment that does not require a reversing valve signaling.

Auxiliary Heat Configuration Options:

Outside Air Lock Out: If the outside air temperature is below the low limit Outside Air Lock Out configuration, the auxiliary heat will be used, and compressor operation will be prevented from turning ON.

¹Pelican offers different sequences for when reheat or central heat will be used as the primary or secondary heating source. Contact Pelican engineering support for further assistance.

Auxiliary: If the Auxiliary Heat configuration is set to Auxiliary, the auxiliary heat will be energized in combination with compressor operation if the zone coordinator calculates that the compressor heat alone is unable to maintain the target supply temperature within a \pm dead-band allowance.

Emergency: If the Auxiliary Heat configuration is set to Emergency, the auxiliary heat will be used in combination with compressor operation if the zone coordinator flags the compressor heat as failing to heat. Failing to heat means the supply temperature is moving in the wrong direction and is not heating at all for an hour of heating operation.

Disabled: If the Auxiliary Heat configuration is set to Disabled, auxiliary heat will NOT be used.

Capacity Management

Some zoned HVAC units do not have small enough first stages of cooling and/or heating to keep the discharge air temperature from getting too cold or too hot during low cooling or heating demands. Additionally, the airflow rate moving over the evaporator or heating coil can become too low when only a few small zones are in cooling or central heating demand.

When this occurs, mechanical safeties can deploy or other mechanical issues can persist. The zone coordinator's Minimum Supply Temperature is designed to be a pre-mechanical safety algorithm to help prevent this occurrence, but Capacity Management is designed to manage this rare situation further.

For Capacity Management to operate effectively, each Pelican zone thermostat must be configured with a zone Size. These sizes indicate how much airflow (CFM) enters the space during a cooling or heating cycle.

Size Options:

- x-small (< 200 sq. ft.)
- small (200 - 500 sq. ft.)
- medium (500 - 1000 sq. ft.) (default)
- large (1000 - 2000 sq. ft.)
- x-large (> 2000 sq. ft.)

When zones have configured sizes, the zone coordinator can be set with a Minimum Cooling Capacity and/or a Minimum Heating Capacity percentage. This prevents mechanical cooling or central heating from being enabled until that percentage of cooling or heating demand is reached.

Initially, when a mechanical cooling or central heating cycle is going to begin, the zone coordinator will communicate to zone thermostats that the specific cycle is going to start. Zone thermostats send confirmation back to the zone coordinator that they have received the notification and adjusted their dampers in anticipation of the cycle. If the percentage of zones that

Sequence of Operations

can accept airflow is at or above the configured Minimum Capacity Percentage for that cycle, the cycle will be enabled. If the percentage of zones that can accept airflow is below the configured Minimum Capacity Percentage for that cycle, the cycle will be held in "Waiting" until the minimum capacity percentage is met.

This strategy is designed to prevent mechanical cooling or central heating from starting when there is not enough airflow available. This algorithm should only be used as a last resort option since it can create discomfort in some zones during low cooling or low heating periods.

Additional logic can be deployed in relation to Capacity Management, such as, but not limited to: Limited Zone Dump PID loops, Full Dump configurations, Allow Zero Heat Stages, adjustments to Minimum and Maximum Supply Temperature allowances, different target supply temperature resets and/or staging strategies, etc.

Dehumidification

The zone coordinator can be configured to provide dehumidification using various strategies. This requires one or more zone thermostats with a relative humidity sensor for control.

When using a humidity sensor to control dehumidification, a humidity set point is available at each thermostat. When the thermostat detects the humidity has risen above the set point, it will send a dehumidification request to the zone coordinator.

The zone coordinator will enter dehumidification mode, which can include, but is not limited to: enabling compressors to reduce supply air humidity levels, modulating a reheat source to temper the supply air as it returns to zones, enabling a hot gas bypass, and/or activating another reheat or dehumidifier source.

The dehumidification cycle will continue until all thermostats' relative humidity readings fall to or below their set points, dehumidification demand is no longer active, and/or a heating or cooling cycle starts which supersedes the dehumidification cycle.

Dehumidify with Supply Target Tempering:

This sequence is used for the following cases:

- There is central heat that both heats the building and is used to temper the air during a dehumidification sequence.
- There is modulating hot gas bypass that needs to be modulated and is used to temper the air during a dehumidification sequence, and there are no other central heating sources.

If humidity control is configured for Cool+Heat, and all

dehumidification preconditions are met, the zone coordinator will set its bypass damper to 100% bypass, if installed, and then enable the supply fan. If a variable speed fan is installed, it will be set to run at the configured Minimum Operating Speed. The bypass will be adjusted to reduce the amount of bypassed air OR the supply fan's speed will be increased to run above its minimum operating speed to maintain the configured Target Operating Static. As long as the static pressure reading is above the configured Minimum Static and below the configured Maximum Static, and all preconditions are met, the configured number of mechanical cooling stages will be enabled, and the mechanical heating source (hot gas bypass, hot water coil, electric reheat, etc.) will be staged and/or modulated to maintain the configured dehumidification target supply temperature. This will remain true until all zone thermostats' dehumidification demands have been eliminated, one of the preconditions is no longer met, OR a change-over cycle has occurred. Depending on the precondition, an automated reset will occur to try and enable dehumidification again if zone thermostat dehumidification demands still exist and the preconditions are met.

Dehumidify with an On/Off Signal:

This sequence is used for the following cases:

- There is hot gas bypass which needs to be enabled during the dehumidification sequence without the need to be modulated.
- There is electric heat that is ONLY used to temper the air during a dehumidification sequence.

If humidity control is configured for Cool+Dh, and all dehumidification preconditions are met, the zone coordinator will set its bypass damper to 100% bypass, if installed, and then enable the supply fan. If a variable speed fan is installed, it will be set to run at the configured Minimum Operating Speed. The bypass will be adjusted to reduce the amount of bypassed air OR the supply fan's speed will be increased to run above its minimum operating speed to maintain the configured Target Operating Static. As long as the static pressure reading is above the configured Minimum Static and below the configured Maximum Static, and all preconditions are met, the configured number of mechanical cooling stages will be enabled, and the W3 output will be enabled to start the mechanical heating source (hot gas bypass, electric reheat, etc.) without regard to the supply temperature reading. This will remain true until all zone thermostats' dehumidification demands have been eliminated, one of the preconditions is no longer met, OR a change-over cycle has occurred. Depending on the precondition, an automated reset will occur to try and enable dehumidification again if zone thermostat

¹If a Target Dehumidification Static is configured, the sequence will maintain this static set-point, otherwise the Default target is the Target Operating Static.

Sequence of Operations

dehumidification demands still exist and the preconditions are met.

Dehumidify with Supply Target Tempering and On/Off Signal:

This sequence is used for the following cases:

- There is an electric SCR heater that needs to be modulated and is ONLY used to temper the air during a dehumidification sequence.
- There is modulating hot gas bypass which needs to be enabled and modulated to temper the air during a dehumidification sequence.

If humidity control is configured for Cool+Reheat, and all dehumidification preconditions are met, the zone coordinator will set its bypass damper to 100% bypass, if installed, and then enable the supply fan. If a variable speed fan is installed, it will be set to run at the configured Minimum Operating Speed. The bypass will be adjusted to reduce the amount of bypassed air OR the supply fan's speed will be increased to run above its minimum operating speed to maintain the configured Target Operating Static. As long as the static pressure reading is above the configured Minimum Static and below the configured Maximum Static, and all preconditions are met, the configured number of mechanical cooling stages will be enabled, and the W3 output will be enabled to start the mechanical heating source (hot gas bypass, electric reheat, etc.) and be modulated to maintain the configured dehumidification target supply temperature. This will remain true until all zone thermostats' dehumidification demands have been eliminated, one of the preconditions is no longer met, OR a change-over cycle has occurred. Depending on the precondition, an automated reset will occur to try and enable dehumidification again if zone thermostat dehumidification demands still exist and the preconditions are met.

Change-Over Cycle¹

If there are no active heating or cooling cycles, and simultaneous demand occurs for both cycles, the zone coordinator will start on a first-come, first-served basis.

If an active heating or cooling cycle has been in operation for 30 minutes and zone demands are not eliminated, the zone coordinator will take a vote from all zones to determine if a change-over sequence should take place.

Zones with temperatures furthest from their set-point will have higher votes than zones with temperatures close to their set-point.

If the vote for the current cycle exceeds the vote for a change-over, then the zone coordinator will keep the

current cycle active until either the demand is eliminated or another 30 minutes has elapsed, at which point the zone coordinator will immediately change to the opposite cycle.

If the vote for the opposite cycle exceeds the vote for the current cycle, then the zone coordinator will immediately change to the opposite cycle and reset its vote timer. This sequence occurs and resets continuously.

Boiler Controller

If the zone coordinator's Boiler Controller configuration is set to be active, the W output becomes a hot water pump enable and the W2 output becomes a boiler enable signal.

Conditions for Boiler Controller Algorithm:

- **Boiler Supply Water Temperature Reading:** The zone coordinator has a valid Boiler Supply Water Temperature reading.
- **Operating Range:** The boiler supply water temperature reading is above the Minimum and below the Maximum configured Operating Range.

The Boiler Controller algorithm is designed to only run a hot water pump and/or boiler during active heating cycles. This increases the energy efficiency of the building because the hot water pump and boiler will not be active when there is no heating demand.

Because the hot water pump and/or boiler was disabled before the central heating or reheat cycle was requested, there is no hot water in the hot water loop. Therefore, the zone coordinator will wait until its Boiler Temperature reading is within the configured Operating Range, so that when central heating or the reheats are enabled, there is immediate hot water in the water loop and the zones can provide warm air into their zones.

Variable Temperature Linked to Staging

For applications where there are one or more modulating mechanical sources, the zone coordinator can be configured to either link the modulating PID loop to the staging PID loop or leave them operating independently.

Linking the PIDs: This is most common when there are two of the same modulating sources, such as two compressors that fully modulate. It is also used in situations where the first stage needs to ramp to 100% before the second stage is enabled.

Separating the PIDs: Keeping the two PIDs separate is the most common configuration because it generally

¹If Use Priority Cooling is active, cooling will take precedence over heating calls.

Sequence of Operations

brings the discharge air temperature to the target supply temperature more quickly.

Linked PID Sequence:

- **Cycle Start:** During a cycle start, the first modulating source will be enabled at the configured minimum output. The load will be adjusted to maintain the target discharge air temperature.
- **Stage 1 at 100%:** If the first modulating stage reaches 100% and the discharge air temperature is not at the target, the second stage will be enabled, and the first modulating stage will be ramped down to the configured minimum load or a calculated position to keep the total load output balanced.
- **Continuous Adjustment:** The modulating stage will continue to be adjusted to maintain the target discharge air temperature until all available sources are enabled or the target discharge air temperature is met.
- **Disabling Stages:** If the first modulating source reaches the configured minimum output and the discharge air temperature is beyond the target, the modulating source will ramp to either 100% or a calculated maximum output to keep the total load output balanced and disable the unneeded stage. This will continue until all unneeded sources are disabled or the target discharge air temperature is met.

It is important to configure the size of each stage in the zone coordinator so it knows and can calculate how much load each stage is capable of outputting.

Appendix A: Retrofitting Install Process

For retrofit installations that require keeping the existing HVAC system operational while transitioning to the Pelican zoning solution, follow these steps to minimize potential discomfort.

Step-by-Step Instructions:

Step 1: Mount the zone coordinator (page 11) in a location where it can communicate with the Pelican wireless network. This can be either its final installation location or a temporary location.

Step 2: Wire a supply, return, and outside temperature sensor to the zone coordinator (page 27). Accurate readings are not necessary at this stage; the sensors just need to be installed for temporary operation.

Step 3: Connect the zone coordinator to power (page 15).

Step 4: Turn on the zone coordinator and ensure it completes its start-up process (page 29) and connects to the Pelican wireless network (pages 29 & 30).

Step 5: At this stage, the zone coordinator is not controlling the HVAC equipment, so its configurations are not relevant. If desired, you can set configurations now. It is crucial to set Static Pressure to Off, to prevent low static lock-outs and allow zone thermostats to temporarily operate their dampers. The HVAC system should continue operating in its original configuration as Pelican is not yet controlling it.

Step 6: Transition all zone dampers, reheats, and local fans (if needed) to be controlled by Pelican thermostats. Use the Pelican Connect app to link these thermostats to the zone coordinator and enable them to operate their dampers.

Step 7: Once all zones are controlled by Pelican thermostats, turn power Off to the zone coordinator to prepare for mounting and wiring it to the HVAC equipment.

Step 8: Install the zone coordinator in its final location (pages 12 & 13) and correctly mount all temperature sensors (page 27) and the static probe (page 26).

Step 9: If the zone coordinator's location lacks a strong wireless signal, install the antenna where it can effectively communicate with the Pelican wireless mesh network and wire it back to the sub-base (page 11).

Step 10: Wire the zone coordinator to control the HVAC equipment (pages 16 to 23).

Step 11: Turn on the zone coordinator again and confirm it completes its start-up process (page 29) and connects to the Pelican wireless network (pages 29 & 30).

Step 12: Log in to the Pelican Connect app and

Appendix B: Signal Outputs

configure the zone coordinator (pages 31 to 36).

Step 13: Verify that the equipment and zones are operating correctly. The installation is now complete.

The Pelican Connect app provides access to a zone coordinator's signal outputs and analog input/output manual override page. This page is primarily designed for information purposes but can also be used to troubleshoot signals through manual changes.

IMPORTANT

The Signal Output page is a MASTER OVERRIDE feature of the zone coordinator's signals. The zone coordinator DOES NOT know when these signals are being manually changed. It is extremely important that these outputs are only changed during equipment testing and not used if not well understood. If one or more signals are manually changed, they must be changed back to the correct state.

IF THESE WARNINGS ARE CONFUSING, STOP WHAT YOU ARE DOING AND CONTACT PELICAN TECHNICAL SUPPORT FOR FURTHER ASSISTANCE.

Relay Outputs:

Each Relay Output shows the current output state from that terminal of the zone coordinator.

- **Gray** means the output is disabled.
- **Green** means the output is enabled.

If the output button is pressed, a signal will be sent to the zone coordinator to change the selected output's state. The Pelican Connect app will update the output when the app receives confirmation from the zone coordinator that it has received and changed the signal.

Analog Signals:

Each Analog Output shows the current voltage (V DC) output from that terminal. Analog output sliders will only allow for manual control if the modulation logic linked to that output is disabled. If modulation logic is enabled, the slider might move temporarily, but the zone coordinator will ignore the change within a few minutes.

Each Analog Input shows the current voltage either being outputted or inputted into that terminal of the zone coordinator.

Appendix C: DirectLink

DirectLink provides an RS-485 communication bus for a Pelican zone coordinator. This communication link only supports very specific applications. If you believe it is needed for your application, please contact Pelican engineering for further assistance. For instructions on how to wire the antenna to the zone coordinator's sub-base, reference page 13.

Step-by-Step Instructions:

Step 1: Remove the cover from the zone coordinator. To remove the antenna from the zone coordinator's sub-base: hold the sub-base and gently pull the antenna away from the three-pin connector.

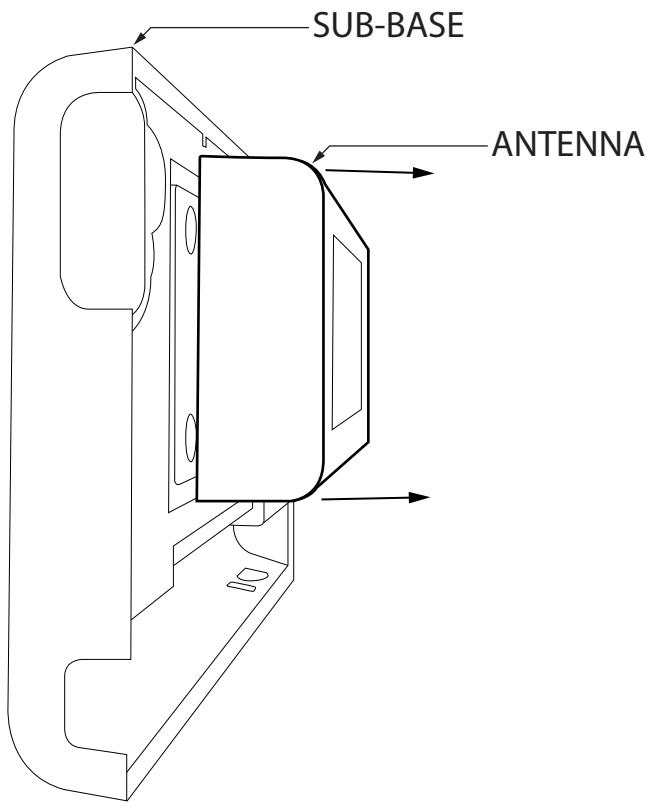

Step 2: Install one of the provided 3-pin connectors at the R, C, D terminal block and the second 3-pin connector at the ground, +, - terminal block on the antenna. The male connector will only fit into the female input in one orientation. Never force the connector as this may cause damage.

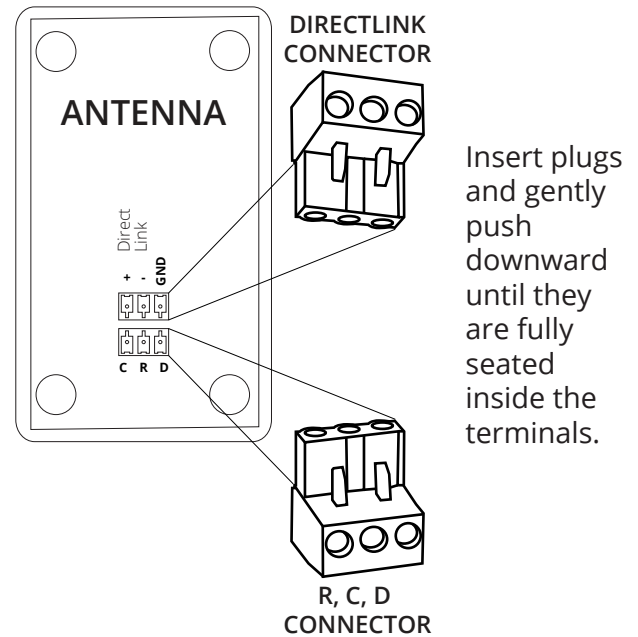

Step 3: Run new or use existing 18-3 unshielded thermostat wire between the antenna and the zone coordinator's sub-base. Maximum wire length is 500 feet.

Wire the R, C, and D terminals at the antenna to the matching R, C, and D terminals at the sub-base.

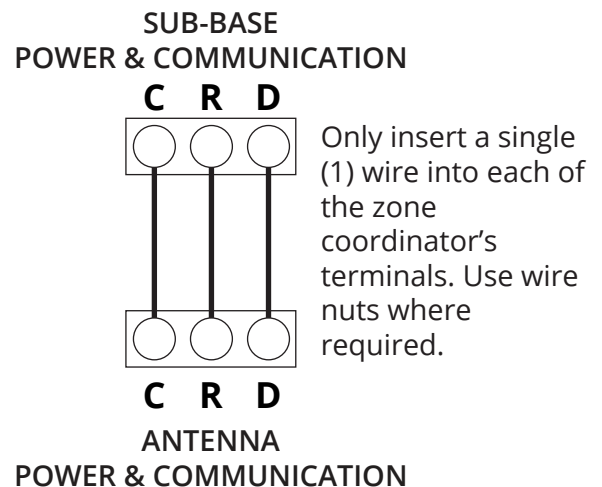

Step 4: Run new or use existing shielded 2-wire twisted pair between the antenna DirectLink terminals and the third-party communication link. Maximum wire length is 100 feet.

Communication: Wire + and - to the third-party device's corresponding + and - terminals.

Reference: If required, wire GND of the third-party device's corresponding GND terminal. This is reference ground, not earth ground.

Earth Ground: Wire one side of the shield to earth ground.

Step 5: Follow the instructions on page 13 for antenna mounting.

To set up DirectLink, contact Pelican Technical Support.

2-18 Twisted Wire with Shield:

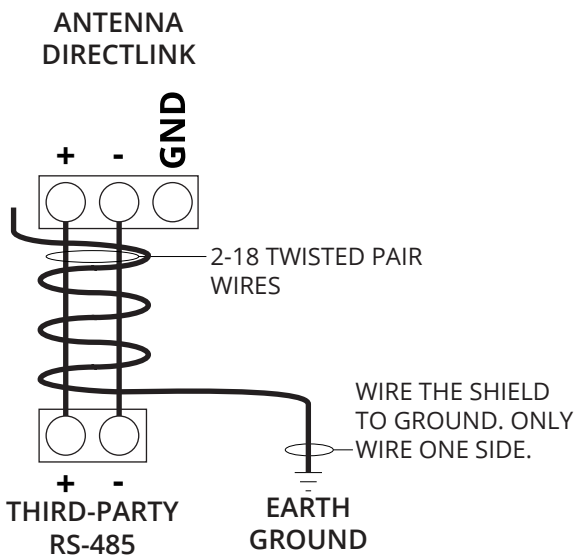

3-18 Twister Wire with Shield:

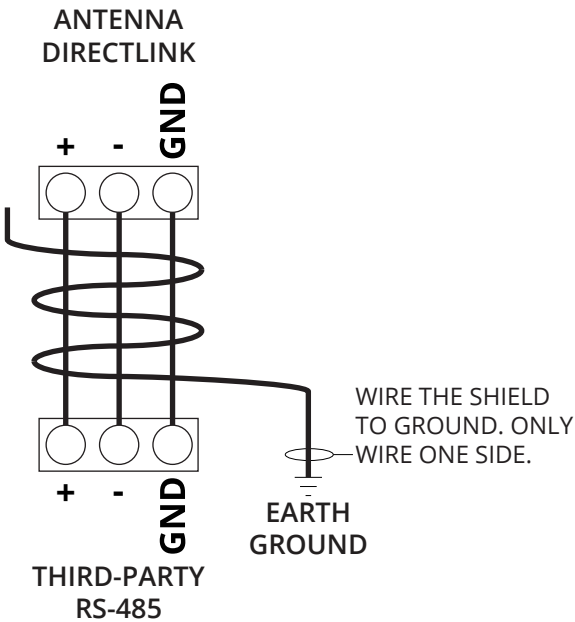

intentionally left blank

