



# Model: TC4

**Commercial Connected Thermostat  
with Humidity and CO<sub>2</sub>**

Installation Guide



## Before you start

---

Review all instructions before starting to avoid discovering or creating any issues during installation. This thermostat is designed to be installed on 24 VAC systems only.

This thermostat is designed to be installed by a licensed professional.

A Pelican Gateway must be used with this thermostat. The thermostat cannot be configured or managed without the gateway. We recommend installing the gateway prior to installing this product.

## Installation location

---

**NEVER INSTALL IN AN ENCLOSED METAL BOX OR ON A METAL SURFACE.**

Install in a location where it can communicate with the Pelican wireless mesh network.

Install 48" to 60" from the floor in the room where it will be maintaining the temperature.

Install on an interior wall away from doors, filing cabinets, electrical equipment, or other metal objects.

## Turn Off power

---

Turn off the power to the equipment this thermostat is going to be wired to. Either turn off power at the circuit breaker panel or by turning off the master power.

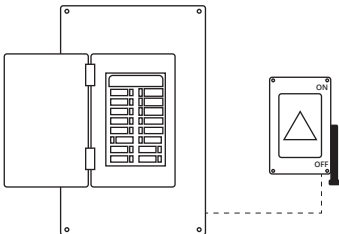

## Replacing an existing wired thermostat

---

Remove the cover from the old thermostat and either take a picture or label the wires as a guide for wiring the new Pelican thermostat.

Uninstall the old thermostat and set aside.

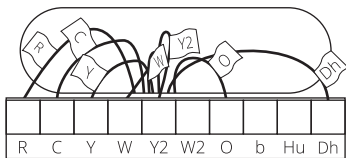

## Installing a Pelican thermostat in a new location

---

This Pelican thermostat is designed to either mount flush on the wall or on a vertical 1-gang electrical box.

**Choose a mounting location where the thermostat:**

is at least 48" to 60" above the floor.

is on an interior wall.

where it can detect the temperature of the room it will be maintaining.

and is away from sun exposure or airflow drafts.

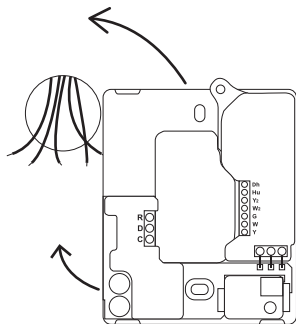

## Install the thermostat back plate

Use the included screws to attach the thermostat to the wall following one of the examples below:

### electrical box installation

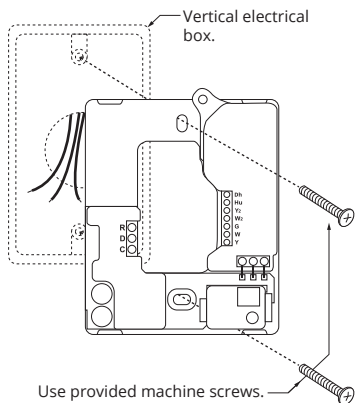

### wall installation

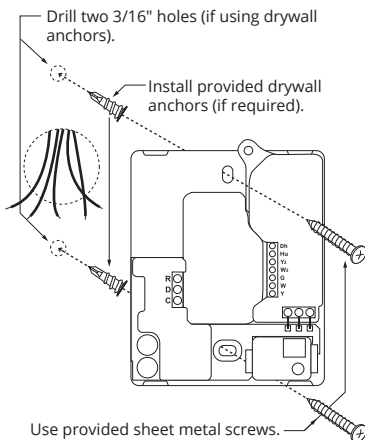

## Connect wires to thermostat

Follow pages 8 – 16 for common thermostat wiring guides.

### Limited Wires? No Common Wire?

Follow pages 4 - 5 for limited wire instructions.

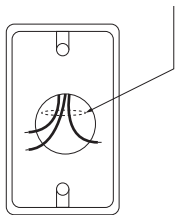

Feed thermostat wire through opening on back plate.

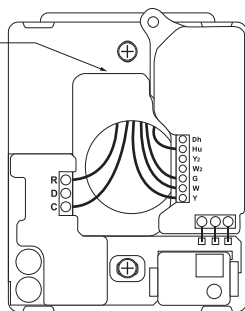

## Limited Wire Installation

Some installations have limited wires between the thermostat and the HVAC equipment. The included Wiring Module can be used to control the HVAC equipment without having to run new or additional wires to the thermostat.

This installation requires at least three (3) wires between the thermostat and the Wiring Module (unshielded wire is okay).

This accommodates a maximum wire distance of 500 feet between the Wiring Module and the thermostat.

### Step 1: Remove the Wiring Module from the thermostat's back plate.

Loosen the (R), (C), and (D) terminals on the Wiring Module. Gently slide the Wiring Module upwards (away from the three pin connector) to remove.

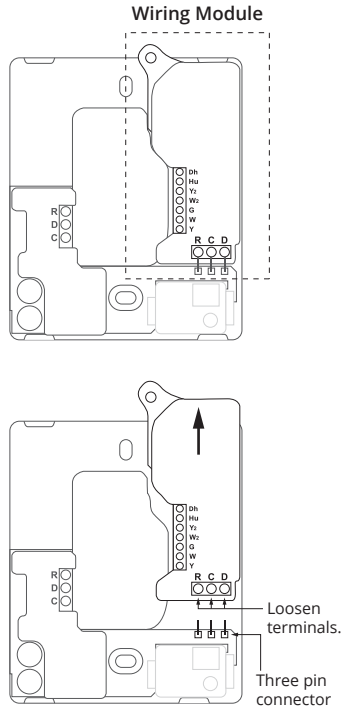

### Step 2: Install the Wiring Module in the HVAC equipment.

Locate the HVAC equipment's control board. Using new wire, connect the Wiring Module's terminals to the corresponding low-voltage input terminals on the HVAC control board.

Follow the wiring diagrams from Pages 8 - 16.

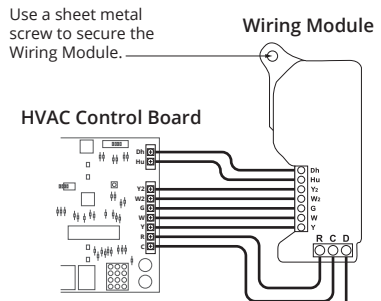

### Step 3: Connect Wiring Module to thermostat.

Use the existing wires from the Wiring Module to where the thermostat is installed to connect the (R), (C), and (D) terminals from the Wiring Module to the matching (R), (C), and (D) terminals at the thermostat's back plate.

Wiring Module mounted at control board.

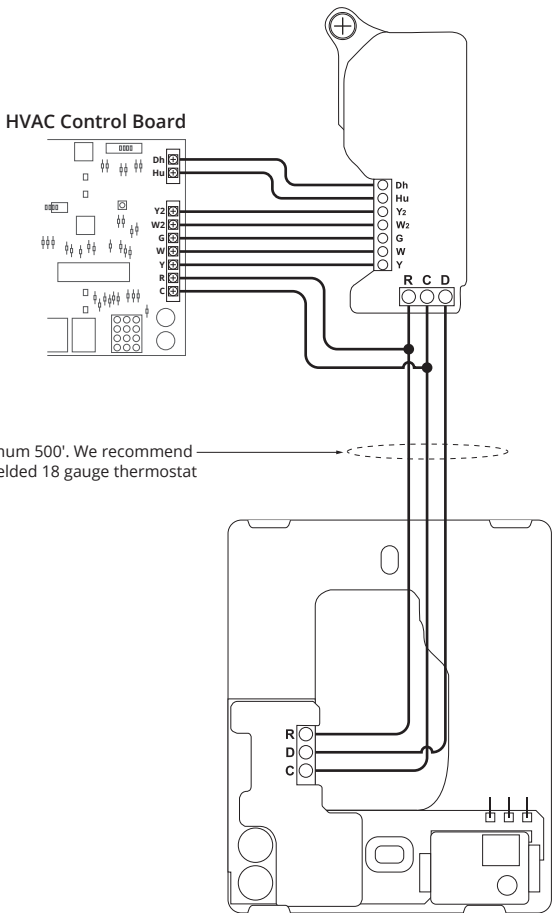

Maximum 500'. We recommend unshielded 18 gauge thermostat wire.

Thermostat back plate mounted in room.

## Attach the display

Before attaching the display, write down the serial number on the screen for use when configuring the thermostat.

Align the display with the back plate's alignment pins. Press into back plate until it clicks into place.

Switch on the power to the HVAC equipment the thermostat is wired to.

If your Pelican thermostat does not power on, see page 17 for assistance.

See page 19 for instructions on setting the thermostat for *Conventional* or *Heat Pump* control.

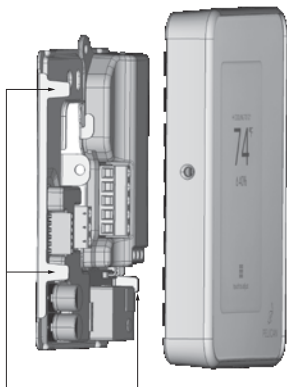

there are three (3) alignment pins found on the left and right sides of the base plate.

## Optional: Tamper Resistant Lock

The thermostat contains an internal locking mechanism to secure the display to the back plate. This is intended to keep unauthorized individuals from tampering with the power and thermostat wire.

To engage the lock, assemble the thermostat and insert a 1/8" flat head screwdriver into the hole on the left side of the thermostat. Push in slightly and rotate 1/4 turn clockwise until reaching the stop. Remove the screwdriver from the hole.

To disengage, insert a 1/8" flat head screwdriver into the hole on the left side of the thermostat. Rotate 1/4 turn counter-clockwise until reaching the stop. Remove the screwdriver from the hole.

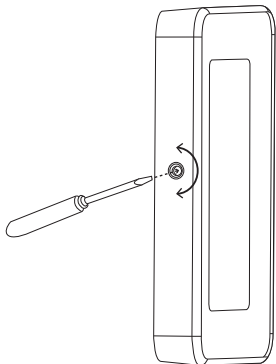

Do NOT force the display from the back plate otherwise damage may occur.

## Wiring Guides

---

For conventional heating and cooling systems, see pages 8 - 9

For heat pumps, see pages 10 - 11

For two-pipe fan coils, see pages 12 - 13

For four-pipe fan coils, see pages 14 - 15

For humidity control, see page 16

For zone damper control, see separate installation guide Zone Damper Control.

For installations that are outside of this installation guide, **STOP INSTALLING THE THERMOSTAT**, and contact Pelican Sales Engineering Support for further assistance at **888.512.0490**.

## 24 VAC Terminal Block Designations

---

### Conventional

DATA	D
COMMON	C
24 VAC POWER	R

COOL STAGE 1	Y
HEAT STAGE 1	W
FAN	G
HEAT STAGE 2	W2
COOL STAGE 2	Y2
HUMIDIFY	Hu
DEHUMIDIFY	Dh

### Two-Pipe Fan Coil

DATA	D
COMMON	C
24 VAC POWER	R

VALVE OPEN	Y
UNUSED	W
FAN	G
AUXILIARY HEAT	W2
VALVE CLOSE	Y2
HUMIDIFY	Hu
DEHUMIDIFY	Dh

### Heat Pump

DATA	D
COMMON	C
24 VAC POWER	R

COMPRESSOR STAGE 1	Y
REVERSING VALVE (O/b)	W
FAN	G
AUXILIARY HEAT	W2
COMPRESSOR STAGE 2	Y2
HUMIDIFY	Hu
DEHUMIDIFY	Dh

### Four-Pipe Fan Coil

DATA	D
COMMON	C
24 VAC POWER	R

CHILLED VALVE OPEN	Y
HOT VALVE OPEN	W
FAN	G
HOT VALVE CLOSE	W2
CHILLED VALVE CLOSE	Y2
HUMIDIFY	Hu
DEHUMIDIFY	Dh

# Conventional Heating and Cooling Systems (Up to 2 stages each)

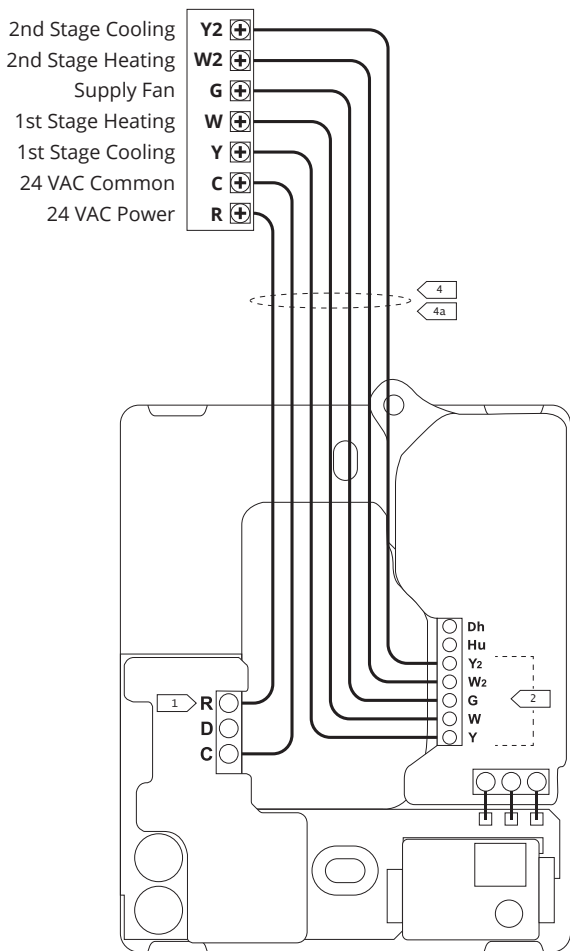

Notes can be found on page 17.



# Conventional Heating and Cooling Systems (Up to 1 stages cool, 2 stages heat, and 2 speed fan)

- High Speed Supply Fan
- 2nd Stage Heating
- Low Speed Supply Fan
- 1st Stage Heating
- 1st Stage Cooling
- 24 VAC Common
- 24 VAC Power

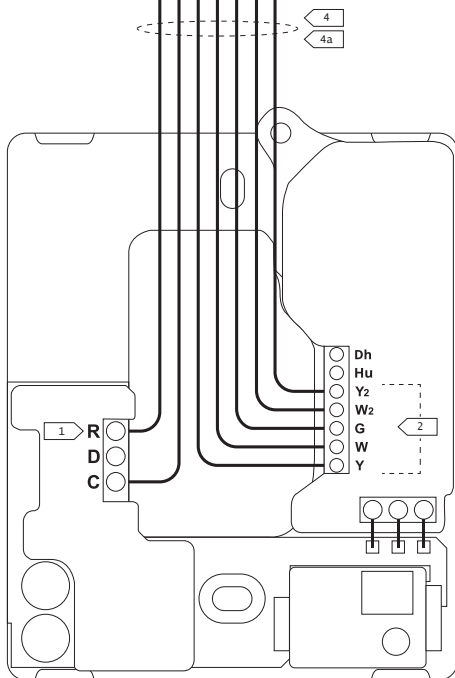

Notes can be found on page 17.

# Heat Pump Systems (Up to 2 stages each and Auxiliary/Emergency Heat)

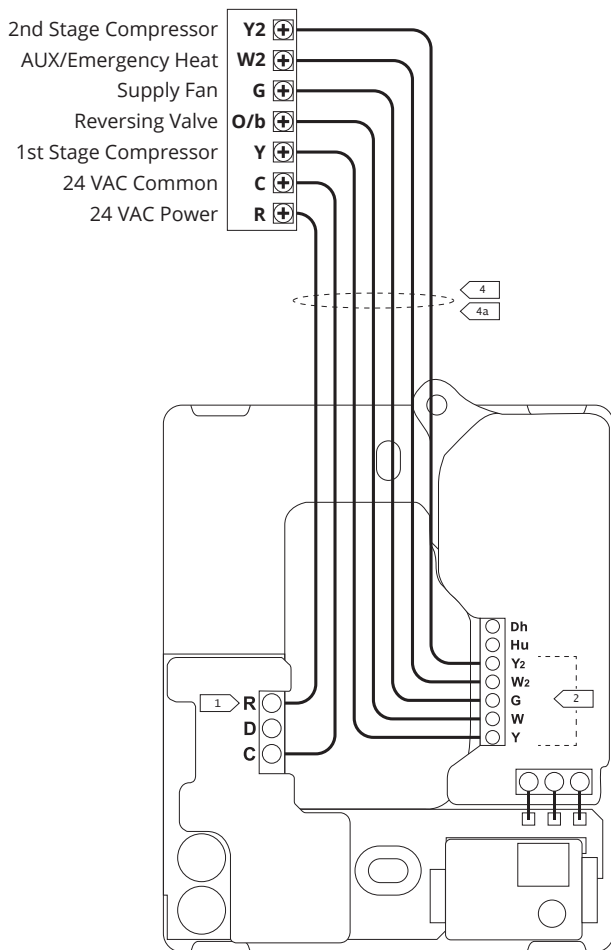

Notes can be found on page 17.

# Heat Pump Systems

(Up to 1 stages each, 2 speed fan, and Auxiliary/Emergency Heat)

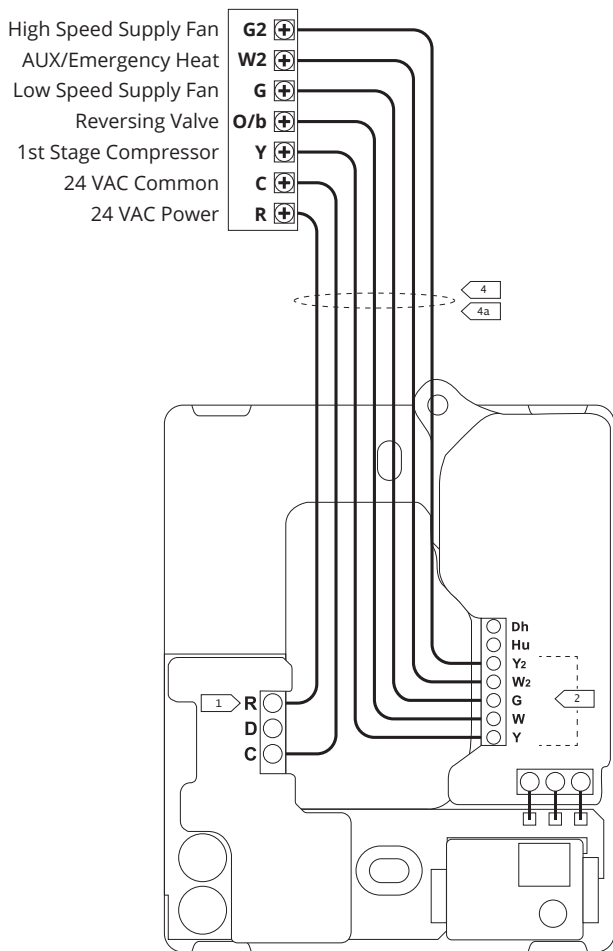

Notes can be found on page 17.

## Two-Pipe Fan Coils\* (Power-open/spring-return or floating water valve)

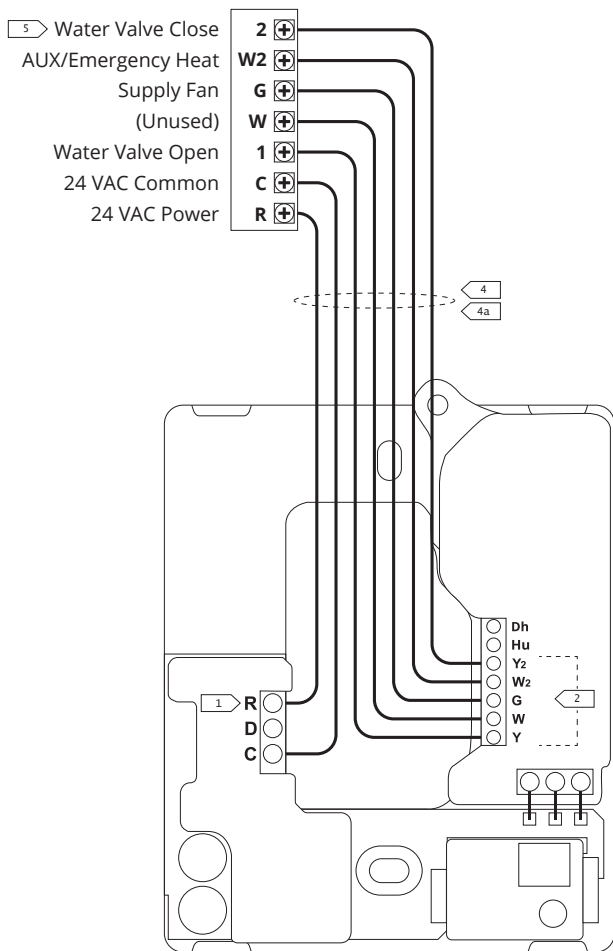

Notes can be found on page 17.

\*Contact Pelican Technical Support for thermostat configuration assistance.

## Two-Pipe Fan Coils\* (Power-open/spring-return water valve and 2 speed fan)

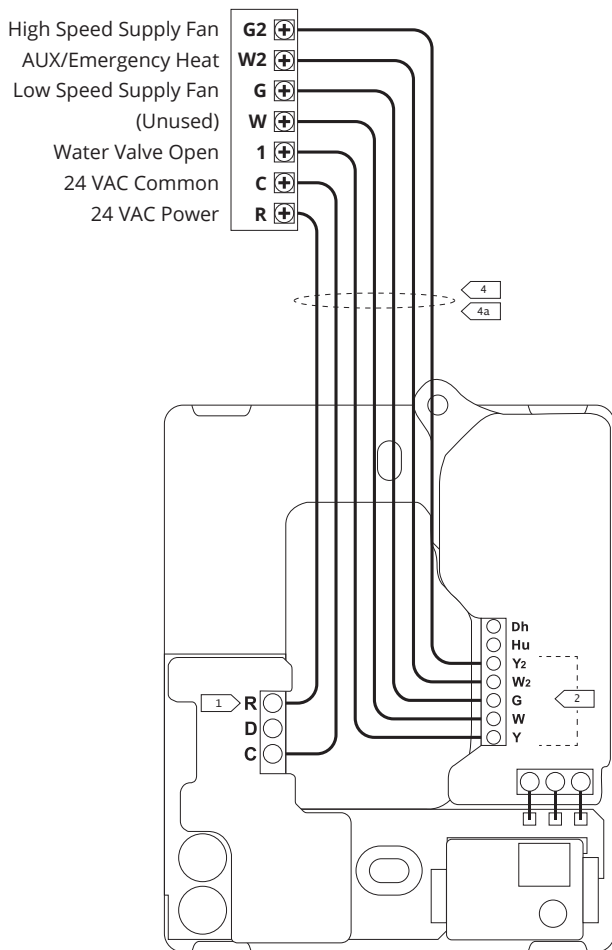

Notes can be found on page 17.

\*Contact Pelican Technical Support for thermostat configuration assistance.

# Four-Pipe Fan Coils (Power-open/spring-return or floating water valve\*)

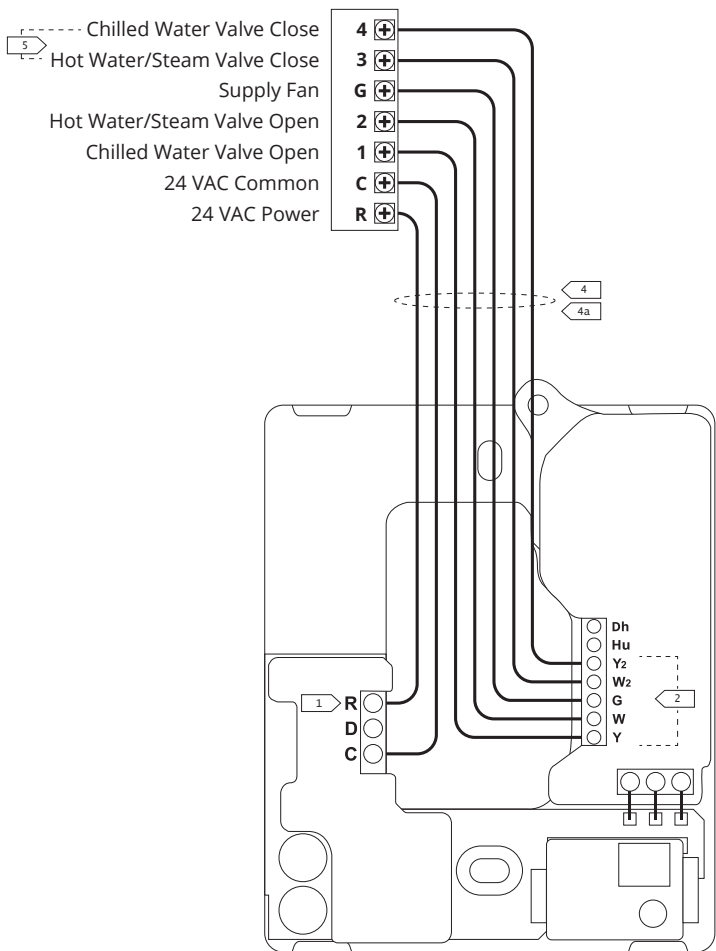

Notes can be found on page 17.

\*Contact Pelican Technical Support for thermostat configuration assistance.

## Four-Pipe Fan Coils (Power-open/spring-return water valves and 2 speed fan)

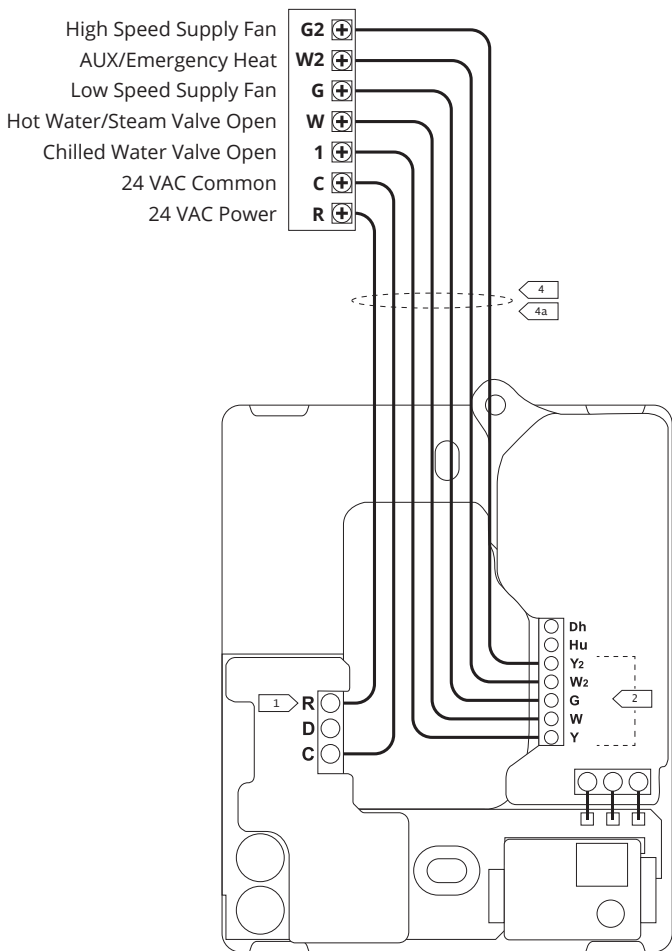

Notes can be found on page 17.

## Humidity Control (Humidify and/or Dehumidify)

---

Dehumidifier/Hot Gas Bypass Enable  
Humidifier Enable

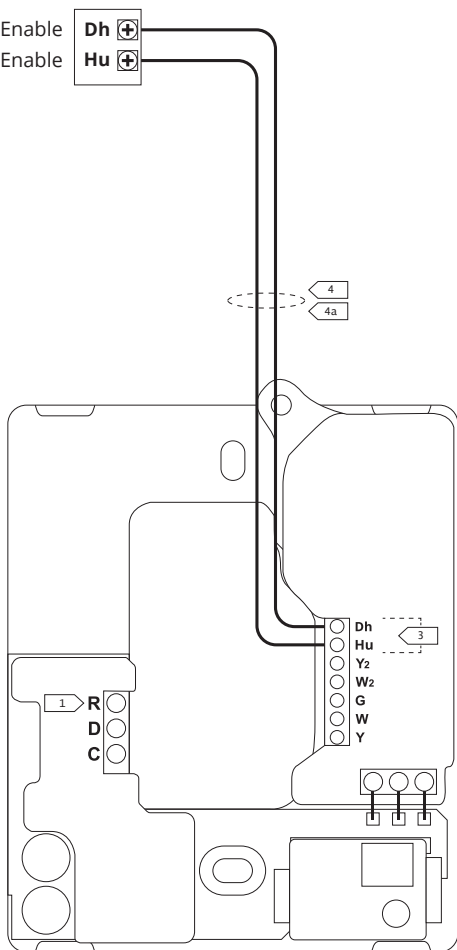

Notes can be found on page 17.



## Notes

---

- 1 Connect to 24 VAC class 2 circuits only.
- 2 Latching relays are rated for 24 VAC @ 2 amps continuous load.
- 3 Latching relays are rated for 24 VAC @ 1 amp continuous load.
- 4 All wire to be installed by customer in accordance with local electrical codes.
- 4a Use 18 gauge unshielded thermostat wire.
- 5 Only found for actuators that are 24 VAC floating type.

## Troubleshooting

---

### If the Pelican thermostat does not power on, check the following:

1. Check that all wires are properly inserted into the terminal blocks at the thermostat and at the HVAC equipment. Lightly pull on the wires to make sure they are not loose.
2. Use a multi-meter to ensure that 24 VAC power is being supplied by HVAC equipment. If 24 VAC is not found, check that the master power has been turned back on for the HVAC equipment or verify that the HVAC electrical breaker has not tripped. If the breaker has tripped contact a Licensed Professional to assist, otherwise damage can occur to the equipment or you can get hurt.
3. Use a multi-meter to ensure that 24 VAC power is found at the thermostat. If 24 VAC was not found, but is found at the HVAC equipment, check for loose or spliced wires.
3. If you used the Wiring Module, use a multi-meter to ensure that 24 VAC power is found at the Wiring Module and the thermostat. Check that the (R), (C), and (D) wires are properly connected between the Wiring Module and the thermostat.

If the thermostat still does not power on, contact Pelican technical support for further assistance at **888.512.0490**.

### If the Pelican thermostat does not show up on the Pelican App, check the following:

1. Check the thermostat upper right hand corner.

If you see this symbol  then the thermostat is unable to connect to your Pelican Wireless Mesh Network.

- Finish installing all your other Pelican thermostats and/or devices.

- Verify your Pelican thermostat is not in a metal enclosure and that there are no metal structures/objects surrounding it. Wireless can NOT communicate through metal.
2. If you see this symbol  then the thermostat is connected to your Pelican Wireless Mesh Network, but your Pelican Gateway is unable to reach the Internet.
- Check your Pelican Gateway to verify it is installed, powered on, and has Internet connection.

If you are unable to get the thermostat to connect to the wireless mesh network or Internet, contact Pelican technical support for further assistance at **888.512.0490**.

## Thermostat Info Page

---

To access the thermostat info, touch *Touch to adjust* and then press the  icon in the upper right hand corner of the screen.

### **Serial Number**

Is the unique identifier for this thermostat. Correlate this number on the Pelican App to configure and name this thermostat.

### **Thermostat Name:**

This is a custom identifier for this thermostat. The thermostat is named using the Pelican App.

### **Configuration:**

This identifies the thermostat's current configuration and provides the ability to change this configuration between Conventional and Heat Pump. This can also be accomplished through the Pelican App where other thermostat configurations are found.

### **Humidity Setting:**

If humidity control is enabled, the thermostat's humidity set-point will be shown under this heading. The set-point can be adjusted by touching the *adjust* button. Otherwise, if humidity control is disabled, Off will be displayed below this heading. Humidity control configurations can be found in the Pelican App where other thermostat configurations are found.

### **CO2 Sensor Reading:**

This is the room's current carbon dioxide (CO2) reading. Demand Ventilation configurations can be found in the Pelican App where other thermostat configurations are found.

### **Model Number:**

This is the model number of this thermostat.

### **Alarm Notifications:**

If there are any icons in the upper right hand corner of the thermostat, the Info page will identify the issue detected. Follow the troubleshooting guide on page 16 for assistance.

## Thermostat Conventional/Heat Pump Configuration Page

---

Within the first 5 minutes after the thermostat was last powered On, the thermostat will allow you to set it to Conventional or Heat Pump control. This can also be done at anytime through the Pelican App.

To access the configuration page, select *Touch to adjust* and then press the ☰ icon in the upper right hand corner of the screen.

Under *Configuration*, you will see the current control setting (default configuration is *Conventional*).

To change the configuration, press the *change* button to the right of *Configuration*. Then touch *Conventional*, *Heat Pump (O)*, or *Heat Pump (B)* and press *Save* at the bottom of the screen to set the new configuration.

If you do NOT want to change the thermostat's configuration, press *Cancel* at the bottom of the screen.

